

MOUNTING AND OPERATING INSTRUCTIONS



EB 3134 EN

Translation of original instructions



Type 46-5 N Differential Pressure Regulator with Flow Limitation
Self-operated Regulators

Edition July 2021



Note on these mounting and operating instructions

These mounting and operating instructions assist you in mounting and operating the device safely. The instructions are binding for handling SAMSON devices.

- For the safe and proper use of these instructions, read them carefully and keep them for later reference.
- If you have any questions about these instructions, contact SAMSON's After-sales Service (aftersaleservice@samsongroup.com).



The mounting and operating instructions for the devices are included in the scope of delivery. The latest documentation is available on our website at www.samsongroup.com > **Service & Support** > **Downloads** > **Documentation**.

⚠ WARNING

Damage to health relating to the REACH regulation.

If a SAMSON device contains a substance which is listed as being a substance of very high concern on the candidate list of the REACH regulation, this circumstance is indicated on the SAMSON delivery note.

Information on safe use of the part affected

- ▶ www.samsongroup.com/en/about-samson/material-compliance/reach-regulation/

Definition of signal words

⚠ DANGER

Hazardous situations which, if not avoided, will result in death or serious injury

⚠ WARNING

Hazardous situations which, if not avoided, could result in death or serious injury

ⓘ NOTICE

Property damage message or malfunction

i Note

Additional information

💡 Tip

Recommended action

1	General safety instructions	4
2	Process medium and scope of application	5
3	Transportation and storage	5
4	Design and principle of operation	5
5	Installation	7
5.1	Mounting orientation.....	7
5.2	Strainer.....	8
5.3	Shut-off valve.....	8
5.4	Pressure gauges.....	8
5.5	Control line	8
6	Operation	9
6.1	Start-up.....	9
6.2	Adjusting the set point	9
6.3	Decommissioning	9
6.4	Sample application	10
7	Maintenance and troubleshooting	12
8	Nameplate	12
9	After-sales service	13
10	Dimensions and weights	14
11	Technical data	15

1 General safety instructions

- All safety instructions and warnings given in these mounting and operating instructions, particularly those concerning installation, start-up, and maintenance, must be strictly observed.
- The device must be mounted, started up or serviced by fully trained and qualified personnel only; the accepted industry codes and practices are to be observed. Make sure employees or third parties are not exposed to any danger.
- According to these mounting and operating instructions, trained personnel refers to individuals who are able to judge the work they are assigned to and recognize possible dangers due to their specialized training, their knowledge and experience as well as their knowledge of the applicable standards.
- The devices comply with the requirements of the European Pressure Equipment Directive 2014/68/EU. Devices with a CE marking have a declaration of conformity, which includes information about the applied conformity assessment procedure.
This declaration of conformity can be provided on request.
- To ensure appropriate use, only use the device in applications where the operating pressure and temperatures do not exceed the specifications used for sizing the device at the ordering stage.
- The manufacturer does not assume any responsibility for damage caused by external forces or any other external factors.
- Any hazards that could be caused in the regulator by the process medium, operating pressure or by moving parts are to be prevented by taking appropriate precautions.
- Proper transport, storage, installation, operation, and maintenance are assumed.

i Note

Non-electric valve versions whose bodies are not lined with an insulating material coating do not have their own potential ignition source according to the risk assessment stipulated in EN 13463-1: 2009, section 5.2, even in the rare incident of an operating fault. Therefore, such valve versions do not fall within the scope of Directive 94/9/EC.

2 Process medium and scope of application

Differential pressure regulator with flow limitation for local heat supplies and large heating networks · Flow rate set points from 0.1 to 1 m³/h · Differential pressure set points 0.2, 0.3 and 0.5 bar · Pressure rating PN 10 · Valve size DN 15 · Suitable for treated water up to 110 °C and non-flammable gases up to 80 °C

The valve closes when the differential pressure exceeds the adjusted set point. The flow rate is limited.

3 Transportation and storage

The regulator must be carefully handled, transported and stored. Protect the regulator against adverse influences, such as dirt, moisture or frost, during storage and transportation.

4 Design and principle of operation

See Fig. 1 on page 6.

The differential pressure regulator basically consists of a valve body (1) with restriction (11), seat (2) and plug (3) as well as a closing actuator with an operating diaphragm (9).

The regulator is designed to limit the differential pressure to a fixed value (0.2, 0.3 or 0.5 bar) and the flow rate to the adjusted set point in local heat supply networks and heating systems.

The medium flows through the valve in the direction indicated by the arrow on the valve body. The flow rate is determined by the area released by the valve plug (3) and the adjustable restriction (11).

The high pressure upstream of the restriction is transmitted to the high-pressure side of the actuator through the control line (7) attached on installing the regulator.

The low pressure downstream of the restriction acts on the low-pressure side (10) of the operating diaphragm (9) through a hole in the valve plug. The differential pressure generated across the restriction is converted into a positioning force by the operating diaphragm. If this force exceeds the force of the installed set point spring (5), the valve closes. In the same manner, the valve opens if the positioning force falls below the spring force.

The flow rate is restricted by turning the set point screw to change the flow cross-section at the restriction.

Process medium and scope of application

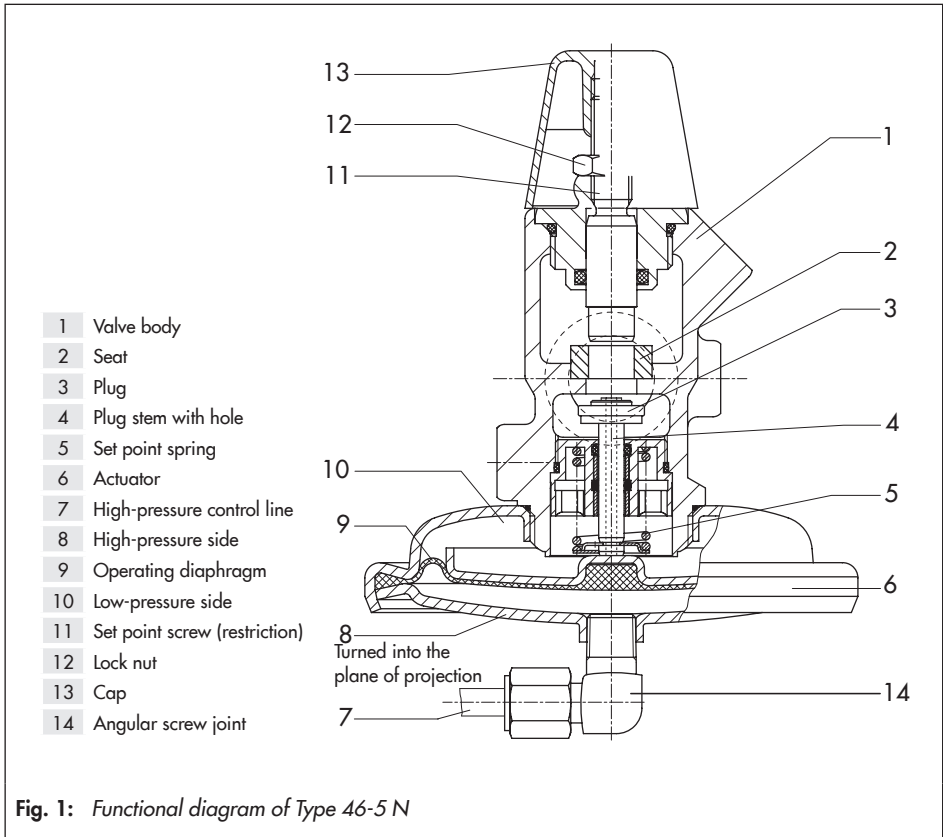

5 Installation

5.1 Mounting orientation

See Fig. 1 on page 6.

The regulators are installed in the low-pressure line. This line is always the return flow pipe in local heat networks.

Standard installation · Install the regulators in horizontal pipelines with the actuator facing down.



The following generally applies:

- Choose a place of installation that allows you to freely access the regulator even after the entire plant has been completed.

- Install a strainer (e.g. SAMSON Type 1 NI) upstream of the regulator (see section 5.2).
- The direction of flow must match the direction indicated by the arrow on the body.
- Connect external control lines at the side of the main pipe. Use the supplied angular screw joint to connect it to the regulator (see section 5.5).

NOTICE

*Incorrectly installed regulator
The regulator can be damaged.
Make sure the regulator is installed free of stress. Observe permissible mounting position.*

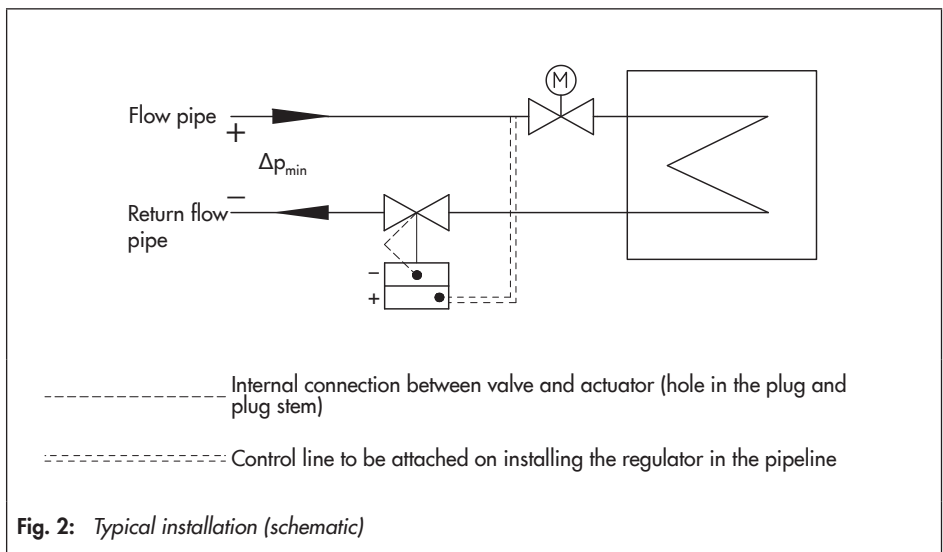

Fig. 2: Typical installation (schematic)

5.2 Strainer

A strainer installed upstream in the flow pipe holds back any dirt or other foreign particles carried along by the medium. For example, the SAMSON Type 1 NI Strainer is suitable (▶ T 1010).

- Do not use the strainer to permanently filter the process medium.
- Install the strainer upstream of the regulator.
- The direction of flow must correspond to the arrow on the body.
- The filter element must be installed to hang downward.
- Remember to leave enough space to remove the filter element.

5.3 Shut-off valve

Install a hand-operated shut-off valve both upstream of the strainer and at the outlet of the return flow pipe. This allows the plant to be shut down for cleaning and maintenance, and when the plant is not used for longer periods of time.

5.4 Pressure gauges

Install a pressure gauge at a suitable point to monitor the pressures prevailing in the plant.

5.5 Control line

A control line with 6 mm pipe diameter must be adapted and mounted on site. Route the control line as indicated in Fig. 2.

An angular screw joint (14) for connecting the control line to the actuator (6) is supplied with the regulator.

- To mount the control line, screw the screw joint clockwise (⌚) into the intended hole on the high-pressure side (8) and align it.

i Note

Do not turn the angular screw joint back again. Otherwise, the connection may start to leak.

6 Operation

See Fig. 1 on page 6.

6.1 Start-up

- Do not start up the regulator until all parts have been mounted.
- Make sure the control line is open and correctly connected.
- Open the shut-off valves slowly over a time period of several minutes starting from the upstream pressure side. Afterwards, open all the valves on the consumer side (downstream of the regulator).
- Open all the consumers in the plant (minimum drag in the plant) to achieve maximum flow rate.

i Note

On filling the plant, make sure the restriction is open by turning the set point screw (11) counterclockwise (↺) as far as it will go.

Rinsing the plant · After filling the plant, first completely open the consumer. Set the maximum flow cross-section (by turning the set point screw counterclockwise (↺) as far as it will go). Rinse out the pipeline at full flow rate for several minutes. Check the installed strainer (e.g. by measuring the pressure drop). Clean the strainer, if necessary.

6.2 Adjusting the set point

If a bypass is installed in the plant, it must be closed.

i Note

Set point adjustment is always based on a closed restriction (11).

1. Unscrew the cap (13).
2. Undo the lock nut (12) and turn the set point screw (11) using a 4 mm Allen key.

→ Turn clockwise (↻):
The restriction closes. The flow rate drops.

→ Turn counterclockwise (↺):
The restriction opens. The flow rate rises.

Use the diagram in Fig. 3 as a guide for adjustment.

3. After adjustment, screw tight the lock nut and screw back on the cap (13).

6.3 Decommissioning

Preferably close first the shut-off valve on the upstream side of the valve and then on the downstream side of the valve.

6.4 Sample application

Adjusting the flow limitation (medium: water) when the pressure loss across the plant is known.

i Note

Set point adjustment is always based on a closed restriction (11).

Known:

- A **Type 46-5 N**, $K_{VS} = 1.0$, flow rate range from **0.12** to **0.5 m³/h** is to be used to limit the flow rate in the plant to **0.3 m³/h**.
- The pressure drop across the plant (Δp_{plant}) is **0.15 bar**.
- The differential pressure set point is **0.3 bar**.
- Determine the adjustment values using the adjustment diagram in Fig. 3.

To be determined:

How many turns of the set point screw are necessary to limit the flow rate?

Solution:

Sequence: points **A** to **E** in diagram (Fig. 3).

The calculation is based on the pressure drop Δp in the plant, therefore, this value must be known.

$\Delta p = 0.15 \text{ bar}$ is specified in the example and corresponds with **point A** in the diagram. The differential pressure at the restriction ($\Delta p_{\text{restriction}}$) assumed to be **0.15 bar** in the example, must be added up to the line of the differential pressure set point of 0.3 bar.

A line representing this value is drawn from **A** across to the right and results in **point B**.

A vertical line is drawn from **point B** until it reaches the limiting curve for the flow rate (in the example, it is 0.3 m³/h). This is **point C**.

The horizontal line is drawn from **point C** across to the curve relevant for $K_{VS} = 1.0$; this is **point D**.

When a line is drawn vertically upwards from **point D**, this results in **point E** which indicates how many turns of the set point screw are required.

The example shows that around 4 turns are required.

Based on a closed restriction, turn the set point screw (11) approximately four turns counterclockwise \cup to open the restriction.

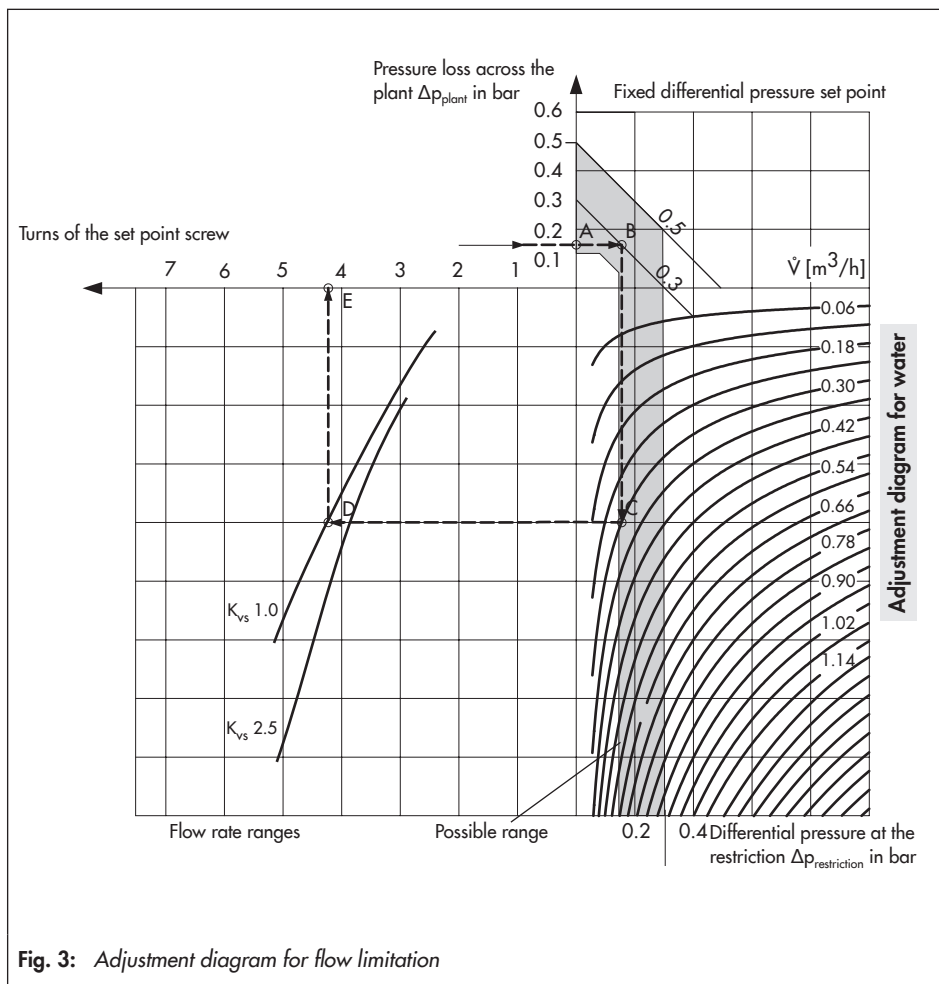

Fig. 3: Adjustment diagram for flow limitation

7 Maintenance and troubleshooting

The regulator does not require any maintenance. Nevertheless, it is subject to natural wear, particularly at the seat, plug and operating diaphragm.

If the flow rate deviates considerably from the set point, first check the control line for blockage. Furthermore, the seat and plug may leak due to dirt particles or natural wear. Therefore, check the regulator and replace it, if necessary.

Depending on the operating conditions, check the regulator at regular intervals to avoid possible malfunctions.

SAMSON's After-sales Service provides support for maintenance and inspection work (see section 9).

⚠ WARNING

Before performing any work on the regulator, make sure the relevant plant section has been depressurized and, depending on the process medium, drained as well. We recommend removing the valve from the pipeline. When used at high temperatures, allow the plant section to cool down to ambient temperature. Disconnect or shut off the control line to prevent the risk posed by moving regulator parts. As valves are not free of cavities, remember that residual process medium might still be contained in the valve.

8 Nameplate

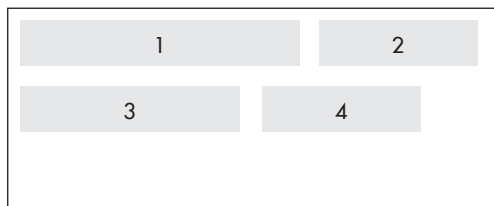

Fig. 4: Nameplate

9 After-sales service

Contact SAMSON's After-sales Service for support concerning service or repair work or when malfunctions or defects arise.

E-mail address

You can reach our after-sales service at aftersalesservice@samsongroup.com.

Addresses of SAMSON AG and its subsidiaries

The addresses of SAMSON, its subsidiaries, representatives and service facilities worldwide can be found on our website (▶ www.samsongroup.com) or in all SAMSON product catalogs.

To assist diagnosis and in case of an unclear mounting situation, specify the following details (so far as possible):

- Device type and valve size
- Model number or material number on the nameplate
- Upstream and downstream pressure
- Temperature and process medium
- Min. and max. flow rate in m³/h
- Is a strainer installed?
- Installation drawing showing the exact location of the regulator and all the additionally installed components (shut-off valves, pressure gauge etc.)

10 Dimensions and weights

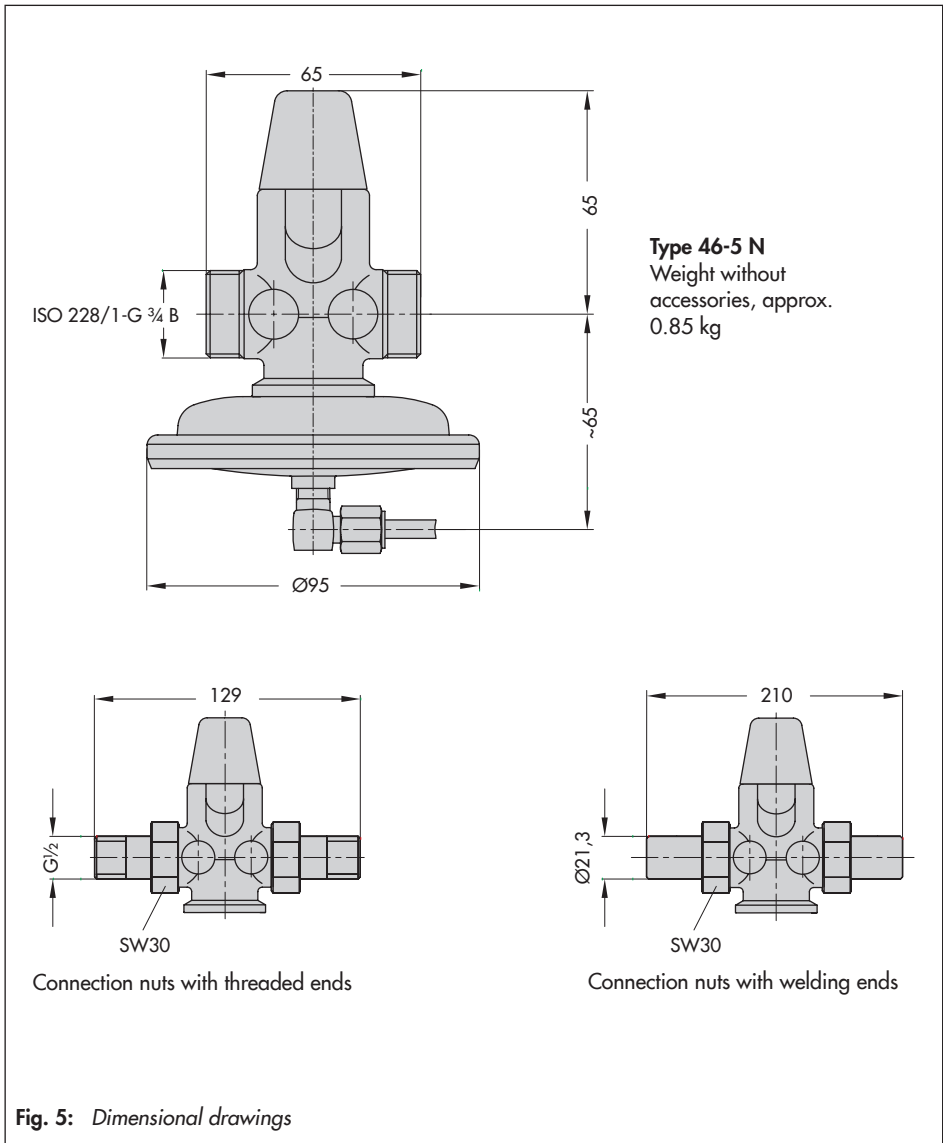

11 Technical data

Valve size		DN 15
Port		ISO 228/1-G ¼ B
Type of connection		Threaded ends G ½ · Welding ends
K _{VS} coefficient	Standard version	2.5
	Special version	1.0
Pressure rating		PN 10
Max. perm. differential pressure Δp		4 bar
Max. permissible temperature	Treated water	110 °C
	Non-flammable gases	80 °C
x _{FZ} value		0.43
Flow set point range for water with diff. pressure at restriction of 0.2 bar	Standard version	0.2 to 1 m ³ /h
	Special version	0.12 to 0.5 m ³ /h
Differential pressure set point ¹⁾ , optionally		0.2, 0.3 or 0.5 bar
Conformity		CE · ER

¹⁾ To achieve the maximum flow rate, the differential pressure set point must be at least 0.2 bar higher than that of the plant.

Dimensions and weights

Pressure conditions in the plant and at the regulator

On selecting the differential pressure set point $\Delta p_{\text{set point}}$, note that the differential pressure set point results from the known pressure drop across the fully open plant and the differential pressure created at the restriction.

$$\Delta p_{\text{set point}} = \Delta p_{\text{plant}} + \Delta p_{\text{restriction}}$$

To achieve the maximum flow rate, the differential pressure set point must be at least 0.2 bar higher than that of the plant. If the differential pressure set point is only 0.1 bar higher than the pressure drop across the fully open plant, the maximum flow rate is reduced to 0.7 m³/h. The minimum required differential pressure Δp_{min} across the valve is calculated as follows:

$$\Delta p_{\text{min}} = \Delta p_{\text{set point}} + \left(\frac{\dot{V}}{K_{VS}} \right)^2$$

Δp_{min}	Minimum differential pressure between the flow and return pipes in bar
$\Delta p_{\text{restriction}}$	Differential pressure created at the restriction for measuring the flow rate
$\Delta p_{\text{set point}}$	Differential pressure set point in bar
Δp_{plant}	Differential pressure (pressure loss) when the plant is completely open in bar
\dot{V}	Adjusted flow rate in m ³ /h
K_{VS}	Valve flow coefficient in m ³ /h

EB 3134 EN



SAMSON AKTIENGESELLSCHAFT
Weismüllerstraße 3 · 60314 Frankfurt am Main, Germany
Phone: +49 69 4009-0 · Fax: +49 69 4009-1507
samson@samsongroup.com · www.samsongroup.com