



Contents

1	Notes on this Configuration Manual	5
1.1	Documentation	5
1.2	Terms and definitions	5
1.3	How to use this configuration manual.....	6
2	Performance features	7
3	Input circuitry	8
3.1	Overview	8
3.2	Input boards (C54)	10
3.3	Assignment of analog inputs (C10 to C13)	12
3.4	Adjustment and calibration (C14)	12
3.5	Monitoring the measuring range (C15, C37)	13
3.6	Filtering of input variables and error (C27)	14
3.7	Root-extraction of input variables (C9).....	15
3.8	Function generation (C7)	16
3.8.1	Instructions and example 1 for function generation	18
3.8.2	Example 2 for function generation	20
3.8.3	Example 3 for function generation	22
3.9	Configuration of binary inputs bi1, bi2 and bi3 (C17, C18 and C19)	24
3.9.1	Changeover of reference variable via binary input (C17/18/19-2 and C21)	24
3.9.2	Initialization of reference variable ramp (C17/18/19-3 and C16-2/-4/-5).....	26
3.9.3	Initialization of output ramp (C17/18/19-4 and C34-4/-5/-11/-12).....	26
3.9.4	Limitation of rate of output changes (C17/18/19-4 and C34-6/-7/-8/-13/-14/-15).....	26
3.9.5	Initialization of safety output values for controller outputs (C17-5/-6, C18-5/-6, 19-6).....	27
3.9.6	Locking of output signals Y ₁ and Y ₂ (C17/18/19-7).....	30
3.9.7	Increase or decrease in the actual value (C17/18/19-8)	30
3.9.8	Reference variable changeover or changeover to follower controller mode (C17/18/19-9)	31
3.9.9	Changeover to manual mode (C17/18/19-10)	32
3.9.10	Changeover to position correction (C17/18/19-11)	32
3.9.11	Locking of manual mode when measuring range monitoring function is activated (C17/18/19-12).....	33
3.9.12	Changeover of digital displays to definition of C4-1(C17/18/19-13).....	33
3.9.13	Activation of limit relay G1 or G2 (C17/18-14).....	33
3.9.14	Locking of operator keys and/or protection against unauthorized modification of configuration and parameter data (C19-14, C59).....	34
3.9.15	Initialization of change of control action (C17/18/19-15, C29-8/9/10).....	34
4	Control modes	36
4.1	Fixed set point control (C1-1).....	37
4.2	Follow-up control (C1-4/5).....	38

4.3	Ratio control (C1-7/8)	40
4.4	Cascade control modes (C1-10/11)	42
4.4.1	Cascade control	42
4.4.2	Modification of the follower controller reference variable for cascade control	44
4.4.3	Limiting control.....	46
4.5	Synchro control (C1-13).....	48
4.6	Feedforward control (C2).....	49
4.6.1	Dynamic behavior of PD elements (C50)	50
4.6.2	Fixed set point control with feedforward control.....	50
4.6.3	Follow-up control with feedforward control.....	56
4.6.4	Ratio control with feedforward control	58
4.6.5	Cascade control modes with feedforward control.....	62
4.6.6	Limiting control with feedforward control.....	66
4.6.7	Synchro control with feedforward control	70
5	Output circuitry	72
5.1	Overview.....	72
5.2	Configuration of controller outputs (C5).....	72
5.2.1	Continuous-action controller outputs (C5-2 to -8)	73
5.2.2	On-off output without feedback (C5-4/-9).....	74
5.2.3	On-off output with pulse-pause converter (C5-5/-10).....	76
5.2.4	Three-step output with external position feedback (C5-6/-11).....	77
5.2.5	Three-step output with internal position feedback (C5-7/-12).....	79
5.2.6	Three-step output with external position feedback and pulse-pause converter (C5-8/-13)	80
5.3	Signal ranges (C31)	82
5.4	Operating direction and split-range operation.....	82
5.4.1	Inversion of error (C6)	83
5.4.2	Operating direction of output variables (C32) and split-range characteristics.....	84
5.5	Output signal limitation (C33, C35, C36).....	88
5.6	Limit relays.....	89
5.6.1	General definition	89
5.6.2	Assignment of limit relays (C40, C41)	90
5.6.3	Limit relays for cascade control.....	90
5.6.4	Limit relays for ratio control.....	90
5.7	Binary outputs.....	91
5.7.1	Configuration of binary output bo1 (C44).....	91
5.7.2	Configuration of binary output bo2 (C45)	91
5.7.3	Binary output bo3	92
5.8	Assignment of the analog output (C48)	92
5.9	Safety output values.....	93
5.9.1	Safety output value Y ₁ K ₁	93
5.9.2	Safety output value Y ₂ K ₁	93
5.9.3	Safety output value Y ₁ K ₃	94
5.9.4	Safety output value Y ₁ K ₄	94

6	Ramp functions	95
6.1	Reference variable ramp (C16)	95
6.1.1	Reference variable ramp with starting condition (C16-2, C17/18/19-3)	96
6.1.2	Reference variable ramp without starting condition (C16-3)	97
6.1.3	Continuous increase and decrease in the reference variable (C16-4, C17/18/19-3, C18/19/17-3)	98
6.1.4	Instantaneous increase and decrease in the reference variable (C16-5, C17/18/19-3, C18/19/17-3)	98
6.2	Output ramp or limitation of the rate of output changes (C34)	99
6.2.1	Output ramp with starting condition by cancelling the safety mode (C34-2/-3/-9/-10, C17/18/19-6)	100
6.2.2	Output ramp with starting condition via binary input (C34-4/-5/-11/-12, C17/18/19-4)	102
6.2.3	Limitation of the rate of output changes (C34-6/-7/-8/-13/-14/-15, C17/18/19-4)	102
7	Additional options of configuration	104
7.1	Limitation of the reference variable or reciprocal set point or actual value ratio (C20)	104
7.2	Assignment of the internal reference variable or set point ratio (C22)	104
7.3	X-tracking (C23)	106
7.4	Dynamic behavior of controller outputs (C24, C25)	106
7.4.1	P controller (C24-1, C25-1)	107
7.4.2	PI controller (C24-2/C25-2)	108
7.4.3	PD controller (C24-3/C25-3)	109
7.4.4	PID controller (C24-4/C25-4)	110
7.4.5	P ² I controller (C24-5, C25-5)	111
7.4.6	Integral controller (C24-6, C25-6)	111
7.4.7	PI, PID and integral controller with correction of the integral-action component (C24-7/-8/-10, C25-7/-8/-10)	112
7.5	Input variable for the D element (C26)	112
7.6	Operating point adjustment (C28, C30)	114
7.6.1	Operating point adjustment via manual mode (C28)	114
7.6.2	Operating point adjustment via reference variable (C30)	114
7.7	Change of control action (C29)	116
7.7.1	P(D)/PI(D) control action (29-2/-3/-4)	116
7.7.2	Y ₀ /PI(D) control action (29-5/-6/-7)	117
7.7.3	Y _{max} /Y ₀ /PI(D) control action (29-8/-9/-10)	118
7.8	Restart conditions upon power supply failure (C43)	119
7.9	Power frequency (C49)	119
7.10	Adaptation of the measuring range of W _{EX} input to the range of X input (C53)	119
7.11	Reset to factory default (C56)	119

8	Display functions	120
8.1	Configuration of digital displays (C4).....	120
8.1.1	Configuration of digital displays in fixed set point control mode (C4)	121
8.1.2	Configuration of digital displays in follow-up control mode (C4)	122
8.1.3	Configuration of digital displays in ratio control mode (C4).....	123
8.1.4	Configuration of digital displays in cascade control mode (C4).....	124
8.1.5	Configuration of digital displays in synchro control mode (C4)	126
8.2	Assignment of the output variable display (C38)	127
8.3	Inversion of the output variable display (C39).....	127
8.4	Display of closed position of the control valve (C42).....	128
8.5	Repetition rate of digital displays and of error display (C46)	128
8.6	Display range of error (C47)	128
8.7	Decimal point on digital displays (C57/58).....	128
Appendix A	Configuration table.....	129
Appendix B	Parameter table	161
Appendix C	Index	167

1 Notes on this Configuration Manual

1.1 Documentation

The documentation of the TROVIS 6412 and 6442 Process Control Stations is made up of two parts: the Mounting and Operating Instructions EB 6412 EN and the Configuration manual KH 6412 EN.

This Configuration Manual KH 6412 EN has been written for experts well experienced in the field of control engineering. Versatile applications determined by selection of configuration blocks and parameters are presented to you in detail. We assume the reader is familiar with the operation of the process control station. If this is not the case, you should consult the Mounting and Operating Instructions EB 6412 EN.

The EB 6412 EN contains information about the installation, electrical connection and operation of the process control station. Additionally, an introduction is given on how to work with the COPA pen, COPA adapter and the associated TROVIS 6482 Configuration and Parameterization Program. The function of the RS-485 interface is also described.

1.2 Terms and definitions

Some definitions will be presented here as it is very important they be understood. The TROVIS 6412 Process Control Station can be adapted to the various types of plants by selecting and adjusting the configuration blocks and parameters.

The **Configuration blocks** are adjusted in the configuration level and designated C1 to C59. Each configuration block can assume different settings. These concrete settings are called **Configuration switches** in this documentation. These are, for example, represented by C1-1, and if there are several possibilities by C1≥2 (this means C1-2 to C1-13). Appendix A lists the complete configuration table.

Parameters are adjusted in the parameter level. The designations in this configuration manual are used in accordance with the symbols used there. To give an example, maximum values are represented by the symbol \approx and minimum values by \preceq . A survey of all possible parameters is provided in Appendix B.



Attention!

Assembly, commissioning and operation of this process control station may only be performed by experienced personnel.

1.3 How to use this configuration manual

The TROVIS 6412 and 6442 Process Control Stations are controlled by a program. The user must adapt this program to the individual requirements of his plant by means of pre-configured functions (configuration blocks) and adjustable parameters. This configuration manual gives advice and instruction on how to use all the possibilities of the program efficiently. Programming skills are not required. The individual configuration blocks are introduced together with their respective parameters. Please note that the order in which they are described does not correspond with the order of the configuration procedure. In the following paragraph, a brief instruction will be provided on how to perform configuration in a useful order. There are two essential aspects which need to be stressed:

First, determine the control mode via configuration block C1. This is important since changing C1 causes all other configuration blocks to be reset to their factory defaults.

Second, do not determine the parameters until configuration has been completed. This must be done since the parameters are enabled with regard to the adjusted configuration switches.

Brief instructions on performing user-specific configuration

1. Determine the control mode by means of C1.
2. Assign the desired analog inputs by means of C10 to C13 according to the adjusted control mode.
3. Determine the controller output by means of C5, C24 and, if needed, C25.
4. Optionally, determine feedforward control by means of C2, C3 and C8.
5. Set special functions, such as signal assignment; ramps; filters; display functions; message functions, as it is required.
6. Determine the required parameters.

2 Performance features

The TROVIS 6412 and 6442 Process Control Stations are microprocessor-based control stations designed for automation of industrial process plants. They are suitable for single control loops as well as for complex control tasks. The two types TROVIS 6412 and TROVIS 6442 Process Control Stations differ from each other only in their style.

Fixed-program function blocks enable the user to select pre-configured control circuits and different functions in a comfortable manner. The selected control mode determines the adjustable configuration blocks and they, in return, determine the adjustable parameters.

There are four different input boards with three or four analog inputs available for the process control station. They may optionally be used for standardized current and voltage signals, potentiometers as well as for Pt 100 temperature sensors, thermocouples or transmitter supply. Additionally, each control station has three binary inputs.

Standard outputs include one continuous-action controller output, one on-off/three-step output and one binary output for error messages.

On request, the functions of the process control stations may be extended by an additional continuous-action controller output, an analog output, two limit relays and two binary outputs. TROVIS 6412 and 6442 can be used for fixed set point control, follow-up control, ratio control or synchro control, and they are also configurable for cascade control or limiting control. In cascade control, the master controller as well as the follower controller are combined in one unit.

The process control stations can be operated, configured and parameterized directly on the control panel via keys. The functions associated with the keys can be locked.

An optional program -TROVIS 6482 - allows configuration and parameterization via PC. Apart from this, the configuration blocks and parameters can be entered in the control units by means of a configuration and parameterization pen (COPA pen).

When used in a process control system, the process control stations can be equipped with a RS-485 serial interface.

3 Input circuitry

3.1 Overview

The digital TROVIS 6412 or 6442 Process Control Station contains three or four analog inputs, depending on the input board. Aside from this, three binary inputs are available.

The analog input signals $A_i 1$ to $A_i 4$ are assigned to an internal signal by means of the configuration blocks C10, C11, C12 and C13. The internal signals are designated X, W_{EX} , Z and Y_{ACTUAT} .

The values of the input signals can be displayed standard within a range of 0 % to 100 % in the A_i level of the process control station. Also in this level, the adjustment of zero and span can be carried out via software according to the description in EB 6412 EN. After the inputs have been assigned to an internal signal, the absolute values of the inputs are displayed in the I-O level.

The input signals can be monitored to check whether they are outside the measuring range. To do this, set the configuration switch C15>1.

It is possible to smooth the internal signals X, W_{EX} , X_d and Z by means of an Pt-1 filter via configuration block C27.

The signal Y_{ACTUAT} can be corrected when multiplied by the parameter K_8 . The parameter K_8 is the correction factor for the Y_{ACTUAT} input and can be adjusted from 0.00 to 19.99.

All four input signals can be root-extracted using configuration block C9.

The signal of one of the four input signals can be assigned to a certain value. Signal assignment (C7) requires entering 7 coordinate points.

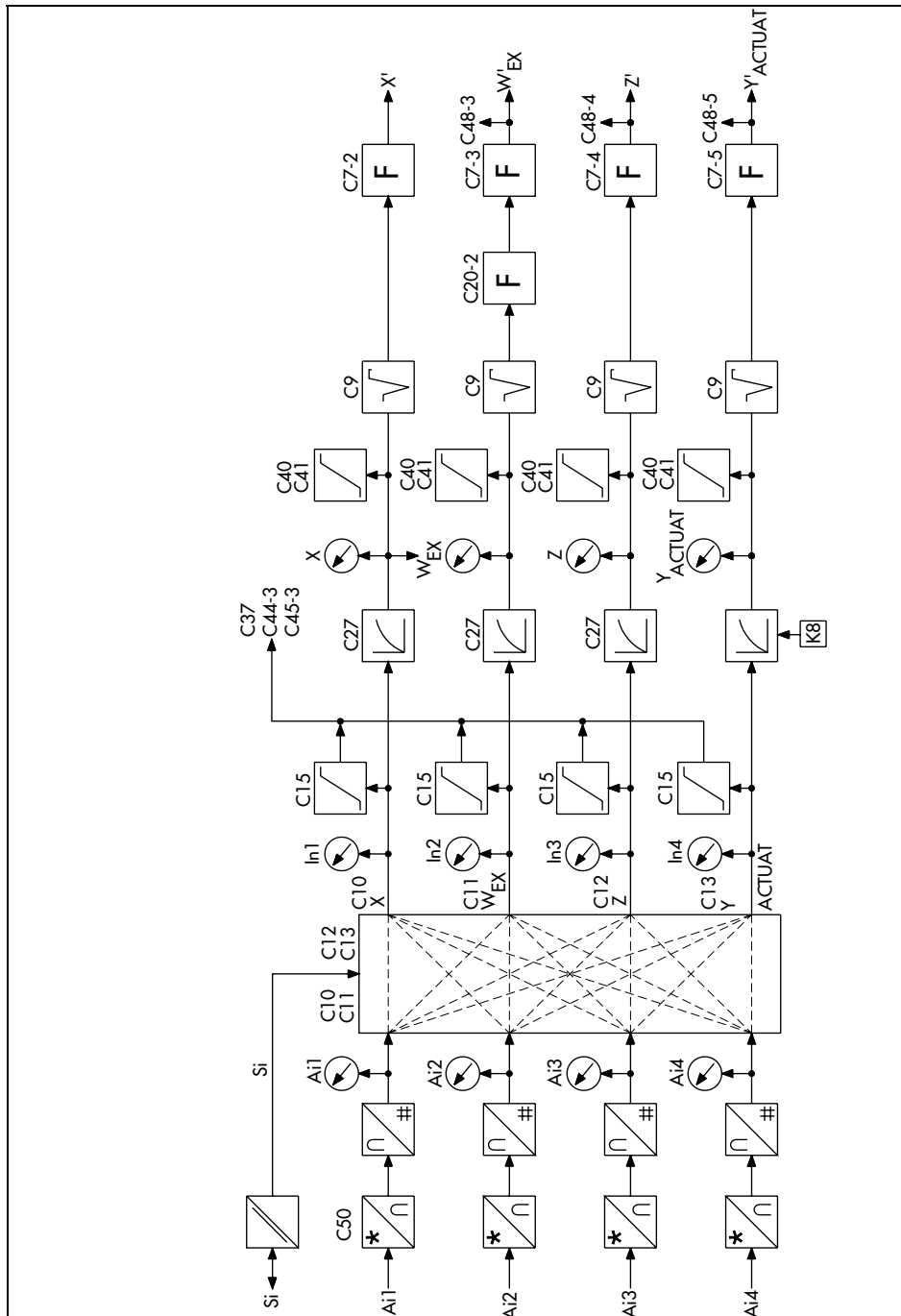

Fig. 1 · Input circuitry

3.2 Input boards (C54)

Four different input boards, each designed for different applications, are available for the process control station.

The individual inputs must be set up for the standardized current and voltage signal, for a potentiometer and, depending on the type of input board, for a Pt 100 resistance thermometer, thermocouple or as two-wire transmitter input. This is done by selecting soldering jumpers.

If Pt 100 resistance thermometers or thermocouples are used, the corresponding input board must be entered in the configuration block C54.

The position of the soldering jumpers and their terminal assignment can be found in the Mounting and operating instructions EB 6412 EN.

The measuring range of the Pt 100 resistance thermometer is determined via soldering jumpers. This measuring range may also be adjusted via software using the parameters $GWK_{1\neq}$ and $GWK_{1\neq}$. When using two Pt 100s this is also done by means of $GWK_{2\neq}$ and $GWK_{2\neq}$.

Example: We assume that the input 1 shall be connected to a Pt 100 with a desired range of 100 to 600 °C. Then, you have to set $GWK_{1\neq}$ to 100 and $GWK_{1\neq}$ to 600.

Depending on which signal has been assigned (X, W_{EX} or Z), the measuring range can be further limited using the corresponding parameters $X\neq$ and $X\neq$ or $W_{EX\neq}$ and $W_{EX\neq}$ or $Z\neq$ and $Z\neq$. The signal Y_{ACTUAT} has a fixed measuring range.

Input board 1 (EK1, C54-1)

This input board has four inputs which can be set up as follows:

Input 1	Standardized current signal	0(4) to 20 mA
	Standardized voltage signal	0(2) to 10 V; 0.2(0) to 1 V; 1(0) to 5 V
	Potentiometer	0 to 1k Ω
	Transmitter supply	16 to 23 V
Input 2	Standardized current signal	0(4) to 20 mA
	Standardized voltage signal	0(2) to 10 V; 0.2(0) to 1 V; 1(0) to 5 V
	Transmitter supply	16 to 23 V
Input 3	Standardized current signal	0(4) to 20 mA
	Standardized voltage signal	0(2) to 10 V; 0.2(0) to 1 V; 1(0) to 5 V
Input 4	Standardized current signal	0(4) to 20 mA
	Standardized voltage signal	0(2) to 10 V; 0.2(0) to 1 V; 1(0) to 5 V
	Potentiometer	0 to 1k Ω

Input board 2 (EK2, C54-2)

The input board 2 has four inputs. One of them can be connected to a Pt 100 resistance thermometer.

Input 1	2-/3-/4-wire	-50 to 100 °C
	Pt 100 resistance thermometer	0 to 200 °C 100 to 600 °C
Input 2	Standardized current signal	0(4) to 20 mA
	Standardized voltage signal	0(2) to 10 V; 0.2(0) to 1 V; 1(0) to 5 V
	Transmitter supply	16 to 23 V
Input 3	Standardized current signal	0(4) to 20 mA
	Standardized voltage signal	0(2) to 10 V; 0.2(0) to 1 V; 1(0) to 5 V
	Transmitter supply	16 to 23 V
Input 4	Standardized current signal	0(4) to 20 mA
	Standardized voltage signal	0(2) to 10 V; 0.2(0) to 1 V; 1(0) to 5 V
	Potentiometer	0 to 1k Ω

Input board 3 (EK3, C54-3)

The input board 3 has only three inputs. Two of them can be connected to Pt 100 resistance thermometers.

Input 1	2-/3-/4-wire	
	Pt 100 resistance thermometer	-50 to 100 °C 0 to 200 °C 100 to 600 °C
Input 2	2-/3-/4-wire	
	Pt 100 resistance thermometer	
Input 4	Standardized current signal	0(4) to 20 mA
	Standardized voltage signal	0(2) to 10 V; 0,2(0) to 1 V; 1(0) to 5 V
	Potentiometer	0 to 1k Ω
	Transmitter supply	16 to 23 V

Note: Input 4 is internally connected with input 3!

Input board 4 (EK4, C54-4)

The input board 4 has three inputs. One can be connected to a thermocouple. When connecting a thermocouple, a reference junction sensor must be used together with it. Additionally, you must enter the type of the thermocouple in the configuration block C55. (see Appendix A)

Input 1	Thermocouple (internal or external reference junction)	
Input 2	Standardized current signal	0(4) to 20 mA
	Standardized voltage signal	0(2) to 10 V; 0.2(0) to 1 V; 1(0) to 5 V
	Transmitter supply	16 to 23 V
Input 4	Standardized current signal	0(4) to 20 mA
	Standardized voltage signal	0(2) to 10 V; 0.2(0) to 1 V; 1(0) to 5 V
	Potentiometer	0 to 1k Ω
	Transmitter supply	16 to 23 V

Note: Input 4 is internally connected with input 3!

3.3 Assignment of analog inputs (C10 to C13)

The analog input signals A_{i1} to A_{i4} or, if needed, the input of the RS 485 serial interface must be assigned to the internal signals X , W_{EX} , Z and Y_{ACTUAT} via software. This is done by defining the configuration blocks C10 to C13. The different possibilities are illustrated in Fig. 2 .

3.4 Adjustment and calibration (C14)

A detailed description of the configuration block C14 can be found in EB 6412 EN in the section "Ai level".

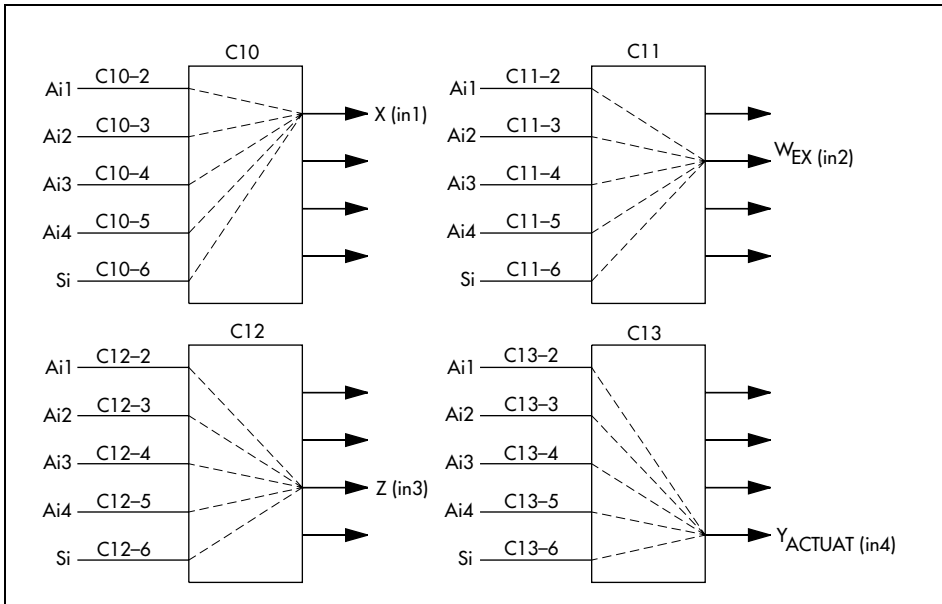

Fig. 2 · Assignment of analog inputs

3.5 Monitoring the measuring range (C15, C37)

The input signals X, Z, W_{EX} and Y_{ACTUAT} can be monitored individually or in any combination to check whether they exceed or fall below the measuring range. Monitoring the measuring range is configured via C15. For precise details, please refer to the configuration table in Appendix A .

When the monitoring function is activated (C15 >1), the symbol 'i' appears on the display of the process control station.

If the measuring range is actually exceeded or not reached, the flashing symbol ■ (collective error message) appears right next to it. Additionally, Ai flashes in the controlled variable display. The red LED is on. This error message is also transmitted to the binary input bo3, allowing the message to be passed on to an external system (see section 5.7.3).

When the monitoring function is activated, it is possible to switch to manual mode via configuration block C37>1 if the signal are outside the measuring range. And, it is possible to determine a certain output variable for the controller outputs Y₁ and Y₂:

C37-1 is factory default and only Ai will be displayed if the signals are outside the measuring range.

In the setting **C37-2**, the process control station switches to manual mode if the signals are outside the measuring range, maintaining the last value of the output variable.

In the setting **C37-3**, the process control station switches to manual mode if the signals are outside the measuring range. The adjustable safety output value Y_{1K1} is issued to the output Y₁. The output Y₂ takes the calculated output variable Y₂ of the split-range unit. As soon as the input signals are again within the measuring range, the manual/automatic transfer switch is released. Now, you can smoothly switch back to automatic mode.

In the setting **C37-4**, the process control station also switches to manual mode in case the signals are outside the measuring range. The adjustable safety output value Y_{2K1} is issued to the output Y₂. The output Y₁ takes the calculated output variable Y₁ of the split-range unit. As soon as the input signals are again within the measuring range, the manual/automatic transfer switch is released. Now, you can smoothly switch back to automatic mode.

The transfer from automatic to manual mode by means of C15>1 und C37>1 whenever the signals are beyond the measuring range can be locked via binary input (C17-12 or C18-12). For further details, please refer to section 3.9.11.

Note:

The safety output values Y_{1K1} or Y_{2K1} are only activated in automatic mode and if C37-3 or C37-4 has been set, provided that the signals are beyond the measuring range.

3.6 Filtering of input variables and error (C27)

Filtering of input variables and error is selected via configuration block C27. You have the possibility of filtering individual signals or also several signals (X , W_{EX} , Z , X_D) at a time, see the configuration table in Appendix A.

This first-order filter (low-pass or Pt1 behavior) smoothes the selected signals and suppresses input signal fluctuations.

The time constant of the Pt1 element can be adjusted in the parameter level by means of the parameters T_{SX} , $T_{SW_{EX}}$, T_{SZ} or T_{SX_D} , depending on the signal to be filtered. This is for example T_{SX} if the input signal X shall be filtered. The time constant is given in seconds.

Note:

Filters are used in controlled systems in order to filter out signal disturbances of higher frequency.

Parameters to be set

T_{SX} , $T_{SW_{EX}}$, T_{SZ} or T_{SX_D} Depending on the signal to be filtered

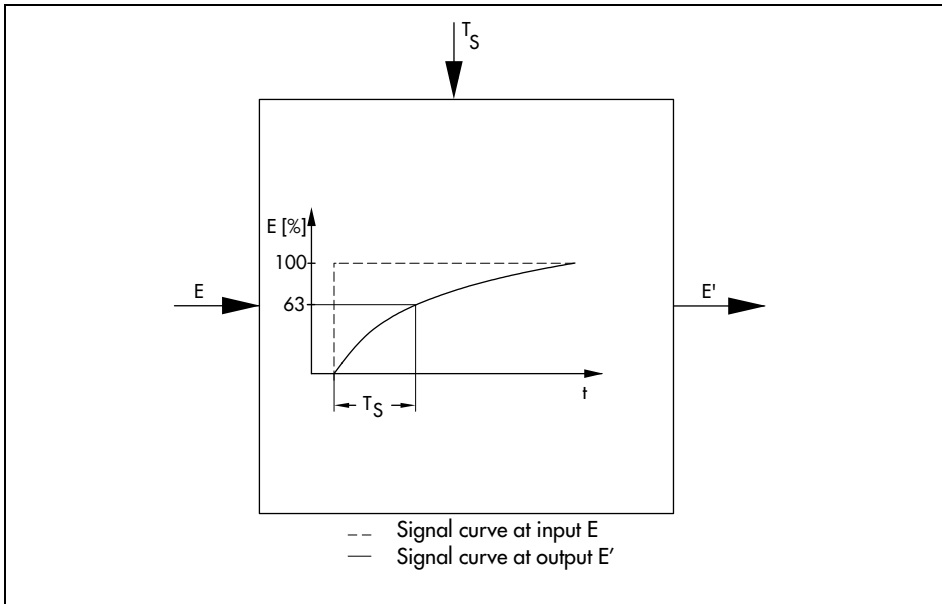

Fig. 3 · Digital filter

3.7 Root-extraction of input variables (C9)

The root-extracting function can be selected via configuration block C9. You may root-extract individual or several input signals (X, W_{EX}, Z, Y_{ACTUAT}).

The root-extracted input signal is internally standardized.

To give an example, the configuration switch C9-2 is used to root-extract the input signal X.

This function may be used to calculate the flow rate from a differential pressure.

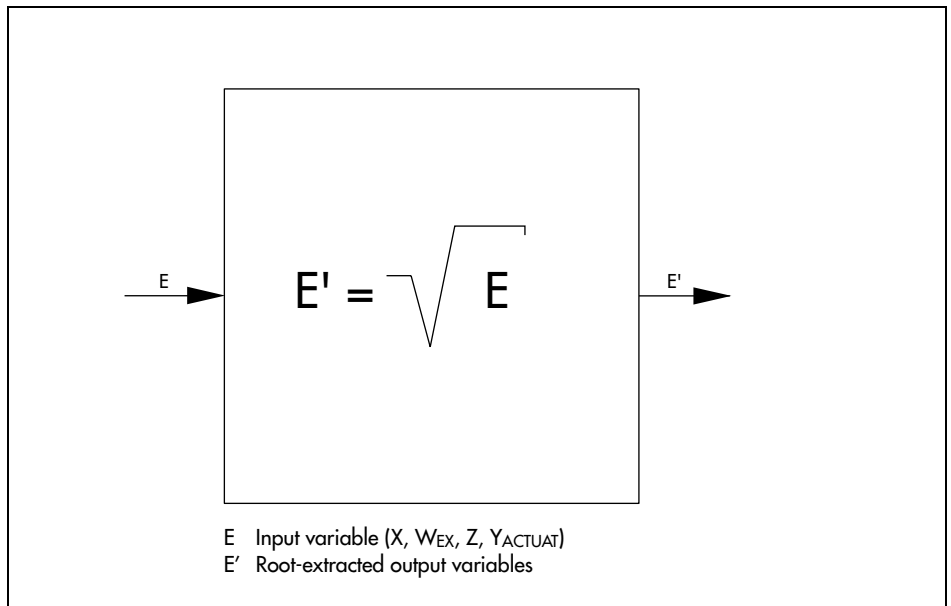

Fig. 4 · Root-extraction

3.8 Function generation (C7)

When a function is generated, a defined signal is re-interpreted to allow further processing. The TROVIS 6412 and 6442 Process Control Stations offer a convenient solution of how to adapt auxiliary, reference or equivalence variables, inherent in measurement or industrial processes, to the controlled system.

The configuration block C7 determines for which signal a function is to be generated (see configuration table in Appendix A). Function generation can be performed only for one signal at a time.

The relationship between the input signal E and the desired assigned output signal E' is known from physical laws, experience or determined values. To integrate this relationship in the process control station, 7 points are required. We recommend to set up a table or to plot the curve in a Cartesian coordinate system. The 7 points must be placed in such a way as to allow easy and clear drawing of straight lines from point to point.

The points must be defined in the parameter level. The values for E (input values) are entered in K_1^{\sphericalangle} to K_7^{\sphericalangle} , the associated values for E' (output values) in K_1^{\sphericalangle} to K_7^{\sphericalangle} . The values are displayed as absolute variables, i.e. in units comprehensible for the operator (in °C, bar or %). The modification of parameters is described in EB 6412 EN.

Even if the signal curve can be sufficiently represented by less than 7 points, you are required to enter 7 points. You may define the unnecessary points as you did it for the last point.

The parameters K_8^{\sphericalangle} and K_8^{\sphericalangle} are used to determine the measuring range of the output signal E'. The measuring range corresponds to that of the input signal E with reference to the output signal E'. Entering these parameters enables software to carry out percentage calculation with the appropriate relationships.

If K_1^{\sphericalangle} or K_7^{\sphericalangle} do not correspond to the minimum K_8^{\sphericalangle} or maximum measuring range value K_8^{\sphericalangle} of the output signal E', the output values for the function-generated signal are constantly set below or above this range to either K_1^{\sphericalangle} or K_7^{\sphericalangle} . The process control station connects the seven points by means of straight lines to form a polygonal curve (see Fig. 6).

If you have entered an output value higher than K_8^{\sphericalangle} or lower than K_8^{\sphericalangle} , this output value will be set to the value of K_8^{\sphericalangle} or K_8^{\sphericalangle} .

In the following sections, we will provide some examples of practical applications.

Note:

The polygonal course of the curve is not limited by the software used with the process control station. Polygonal curves with more than one maximum or minimum are possible. However, ensure one abscissa value is assigned to only one ordinate value. Otherwise, the input signal cannot be clearly assigned to a value.

Point	Abscissa Input E K_{\sphericalangle}	Ordinate Output E' K_{\rceil}
K ₁		
K ₂		
K ₃		
K ₄		
K ₅		
K ₆		
K ₇		

K_1 to $K_7 \sphericalangle$ Input values E
 K_1 to $K_7 \rceil$ Output values E'

$K_{8\sphericalangle}, K_{8\rceil}$ Min. and max. value of measuring range for output values of the function-generated signal. The two values $K_{8\sphericalangle}$ and $K_{8\rceil}$ are based on the input signal.

Example: A function is generated from X
 $W = 30..150^{\circ}\text{C}$, then
 $K_{8\sphericalangle} = 30^{\circ}\text{C}$
 $K_{8\rceil} = 150^{\circ}\text{C}$

Fig. 5 · Inputs for function generation

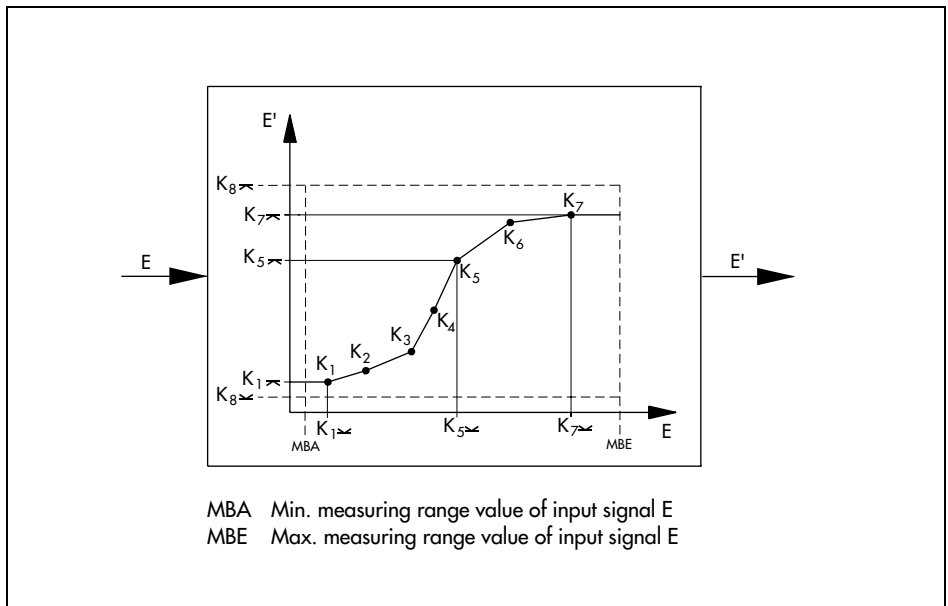

Fig. 6 · Graphical representation of function generation

3.8.1 Instructions and example 1 for function generation

The temperature of a steam-heated calender bowl is to be controlled by means of function generation (see Fig. 8).

Installing a temperature sensor would lead to high costs due to the rotational movement of the bowl. Therefore, another solution must be found. As an alternative, steam pressure measurement will be carried out via pressure transmitter. The steam pressure arriving on the calender bowl can be assigned to a certain temperature value which can be read on a steam table. Special constructional means ensure the respective saturated steam temperature is not exceeded.

With the help of function generation, the operating personnel need not bother reading the steam table. The temperature is directly displayed on the process control station.

For this task, carry out the following steps:

1. Assign the signal of the pressure transmitter to the X input. Select function generation for the X input by means of the configuration switch C7-2.
2. The pressure transmitter has a measuring range of 1 to 9 bar. This corresponds to a temperature range of approx. 100 to 175 °C. Therefore, enter 100 °C for $K_8 \sphericalangle$ and 175 °C for $K_8 \sphericalright$.
3. Plot the pressure-temperature curve with a measuring range of 1 to 9 bar in a Cartesian coordinate system (see Fig. 7). To do this, read off the matching pairs of values in the steam table.
4. Determine 7 adequately distributed points on this curve. Enter the values associated with these points in $K_1 \sphericalangle$ to $K_7 \sphericalangle$ (pressure values) and $K_1 \sphericalright$ to $K_7 \sphericalright$ (temperature values) in the parameter level.

Point	Abscissa Pressure in bar Parameter $K \sphericalangle$	Ordinate Temperature in °C Parameter $K \sphericalright$
K ₁	1.0	100.0
K ₂	2.2	123.2
K ₃	3.4	137.8
K ₄	4.6	148.7
K ₅	5.8	157.52
K ₆	7.4	167.2
K ₇	9.0	175.0

Note

The values of the steam table have been taken from the SAMSON publication "Internal state variables of water and steam "WA 032 Edition March 1988".

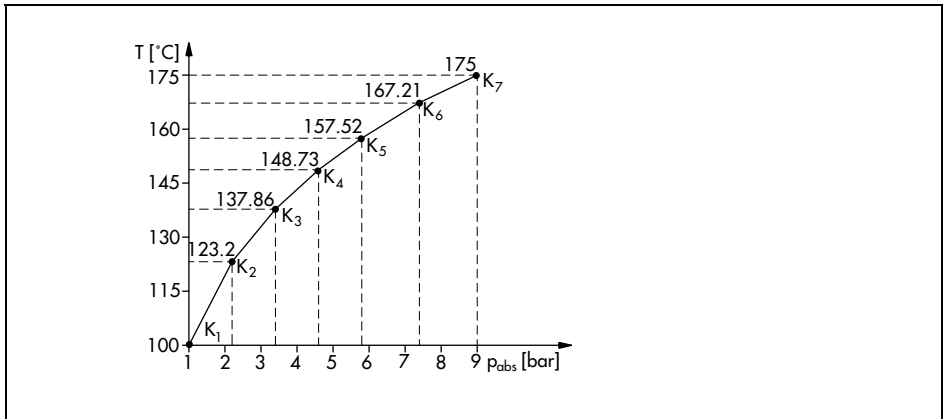

Fig. 7 · Pressure-temperature curve of example 1 for function generation

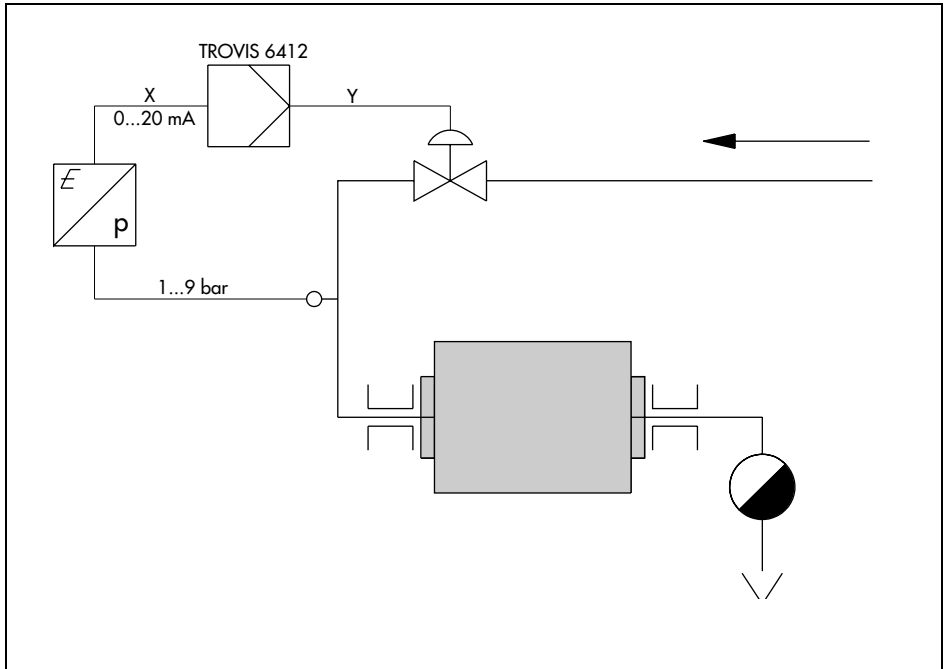

Fig. 8 · Temperature control of a calender bowl

3.8.2 Example 2 for function generation

The liquid level of a tank with a content of max. 15 m^3 is to be controlled via function generation. To do this, select function generation for the X input by means of configuration switch C7-2.

A float and a potentiometer are used to measure the liquid level and transmit it as linear signal ranging from 0 to 1000Ω to the process control station where it is interpreted as measure for the tank content. In fact, the tank content does not depend linearly on the liquid level because of its spherical shape. The actual relationship between these two variables is therefore determined by counting the amount of liters. The outcome is then plotted in a Cartesian coordinate system. Seven points are distributed on the curve (see Fig. 9). The coordinates of these points are entered in the parameter level in $K_1 \asymp$ to $K_7 \asymp$ for the linearly determined volume and in $K_1 \asymp$ to $K_7 \asymp$ for the actual volume. Hence, the input signal is re-interpreted.

The measuring range of input X must be set to 0 to 15 m^3 in the parameter level. The parameters $K_8 \asymp$ and $K_8 \asymp$ are also set to the measuring range of the input X (0 to 15 m^3).

The measuring range of the internal reference variable is set to the measuring range of the function-generated input signal: $W_{IN \asymp} = 0 \text{ m}^3$, $W_{IN \asymp} = 15 \text{ m}^3$

Point	Measured signal in Ω	Abscissa Input signal E in m^3 Parameter K \asymp	Ordinate Output signal E' in m^3 Parameter K \asymp
K ₁	0	0	0
K ₂	200	3	1.6
K ₃	400	6	5.3
K ₄	500	7.5	7.5
K ₅	600	9	9.7
K ₆	800	12	13.4
K ₇	1000	15	15

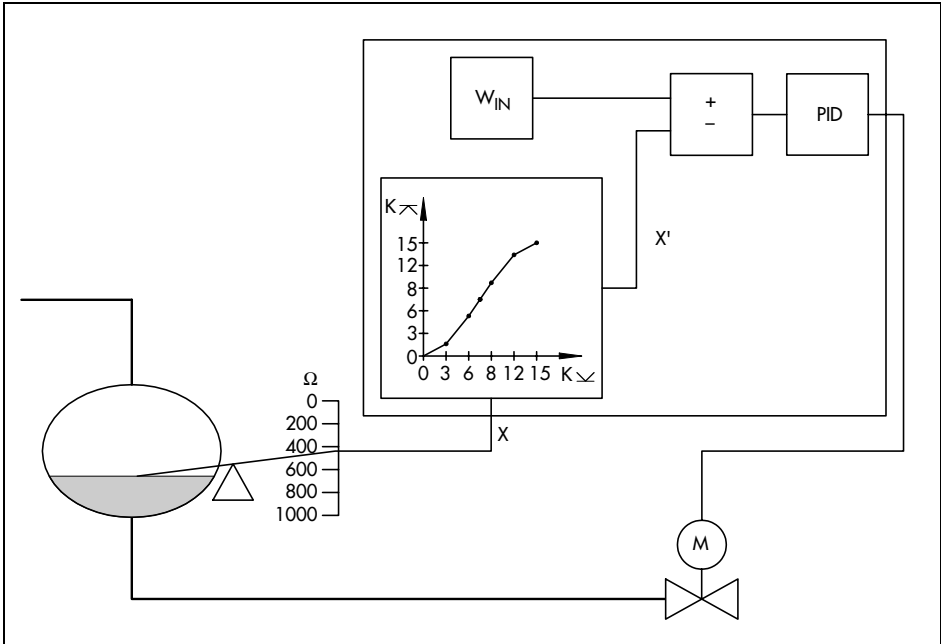

Fig. 9 · Function generation of the liquid level

3.8.3 Example 3 for function generation

Weather-sensitive flow temperature control will serve as the next example.

Follow-up control with external reference variable (C1-4) is used for this task. Here, the controlled variable X (flow temperature) depends on the external reference variable (outdoor temperature).

In this case, function generation is applied to the external reference variable. The outdoor temperature is interpreted by generating a function of the flow temperature. The relationship between outdoor temperature and required flow temperature is known from experience and is represented as curve in the Cartesian coordinate system. Seven characteristic points must be distributed on the curve and their coordinates entered in the parameter level in K_1 to K_7 .

$K_1 \sphericalangle$ to $K_7 \sphericalangle$ contain the outdoor temperatures, $K_1 \sphericalright$ to $K_7 \sphericalright$ the associated flow temperatures. The comparator can now compare the function-generated outdoor temperature (set point of the flow temperature) directly with the measured flow temperature.

The parameters $K_8 \sphericalangle$ and $K_8 \sphericalright$ must be set to the measuring range of the input signal X . The values depend on the plant and are in this case set to 20° and 120° C.

$W_{EX \sphericalangle}$ must be set to -20° C and $W_{EX \sphericalright}$ to 40° C.

Point	Outdoor temperature t_A in $^\circ$ C Parameter $K \sphericalangle$	Flow temperature t_v in $^\circ$ C Parameter $K \sphericalright$
K_1	-20	100
K_2	-10	90
K_3	0	85
K_4	10	75
K_5	20	60
K_6	30	55
K_7	40	50

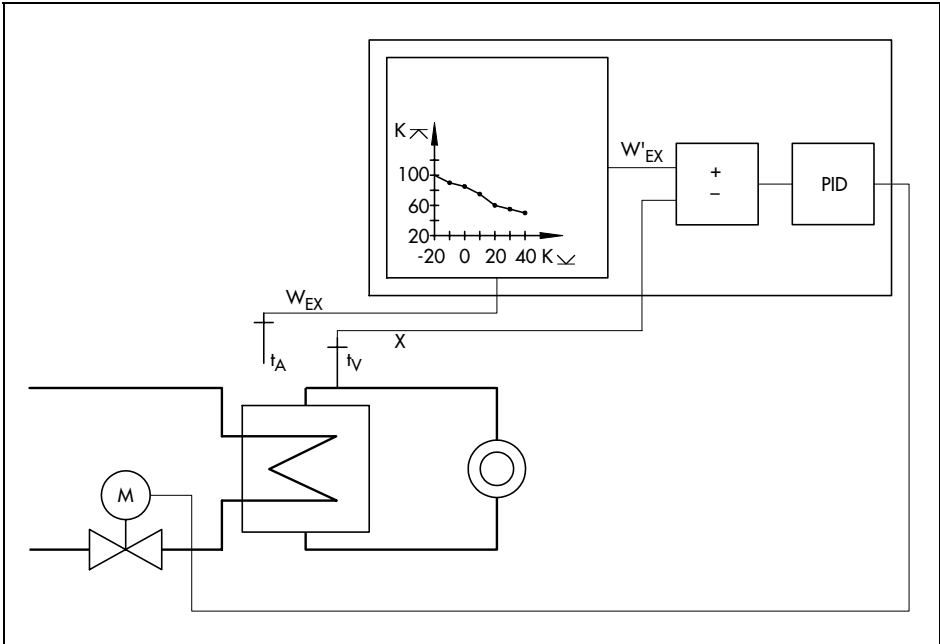

Fig. 10 · Function generation used for weather-sensitive flow temperature control

3.9 Configuration of binary inputs bi1, bi2 and bi3 (C17, C18 and C19)

The process control station has three binary inputs which are assigned to different functions in the controller, depending on the setting of the configuration blocks. These are C17 for binary input bi1, C18 for binary input bi2 and C19 for binary input bi3.



The configured function is performed when the corresponding input is open. The process control station recognizes the open input as logical "1" (positive logic). Opening and closing take place very quickly, however, the binary input must stay open for at least 300 ms so that the pulse can be recognized as signal. The binary input is reset by closing.

The status of the binary inputs can be inquired in the I-O level, independent of the setting of the configuration blocks C17 to C19.

The following sections will describe the individual configurable functions of the binary inputs. Some functions can be assigned to all binary inputs, others only to certain binary inputs. The section headlines indicate with the help of the configuration blocks C17, C18 and/or C19, which of the described functions can be assigned to which binary input/s. Equal functions should not be assigned to several binary inputs at a time since only one of them will be enabled. The discussed functions are always described with only one binary input, respectively.

C17-1, C18-1 and C19-1 is the factory default of the three binary inputs, saying that no functions have been assigned to them.

3.9.1 Changeover of reference variable via binary input (C17/18/19-2 and C21)

This function is selected by configuration switch C17-2. When the binary input is activated (opened) upon external system failure, faults etc., a definable value is determined for the reference variable. The desired value must be adjusted via configuration block C21 (reference variable upon external system failure). The selected configuration switch C17-2 is represented by the symbol  which indicates that the system is not ready. When activating the binary input, the symbol  appears next to the symbol mentioned above.

When changing the reference variable via binary input, the current reference variable (W_{IN}) will not be stored in EEPROM. This is not the case when the change is performed via key (B).

The following reference variables can be activated after having opened the corresponding binary input (see Fig. 11):

C21-1 activates the last reference variable.

In fixed set point control mode (FSP), the last reference variable will be activated. The internally set reference variable cannot be changed anymore in the operating level. It can only be modified in the parameter level and becomes effective as soon as the binary input is deactivated.

In follow-up control mode (FO1), the external reference variable will be frozen, i.e. changes in the reference variable are not considered for control. After the binary input has closed, the current external reference variable will be used again.

In follow-up control (FO2) or ratio control mode (RC2) with internal/external reference variable changeover, the key (B) is locked until the binary input is closed.

In cascade control mode (CA1), the cascade can still be interrupted via key (B). The internal reference variable cannot be changed in the operating level. You may only carry out modifications in the parameter level.

If cascade control (CA2) with external reference variable has been selected, the current reference variable (W_{EX}) is referred to as last reference variable.

C21-2 takes the safety set point (W_S) as reference variable. W_S must be adjusted in the parameter level.

In follow-up control (FO2) or ratio control mode (RC2) with internal/external reference variable changeover, the selector key (B) is locked until the binary input is closed. Provided the external reference variable is active and the binary input is open, the safety set point W_S is taken as current reference variable. The external reference variable is not used for control until the binary input is closed.

C21-3 takes the current actual value (X) as reference variable. Control modes with preset external reference variable use X as internal reference variable. The external reference variable is not valid until the binary input is closed.

C21-4 takes the safety set point (W_S) as reference variable. At the same time, this safety set point (W_S) overwrites the internal reference variable, thus supporting smooth transfer to standard mode. This configuration switch is not available for FO1, CA2 and SY (see configuration table in Appendix A).

Note:

If the safety set point (W_S) is activated (C21-2, C21-4), the reference variable ramp is deactivated. In case a reference variable ramp without starting condition has been defined (C16-3), it will be activated again as soon as the internal or external reference variable replaces the safety set point W_S .

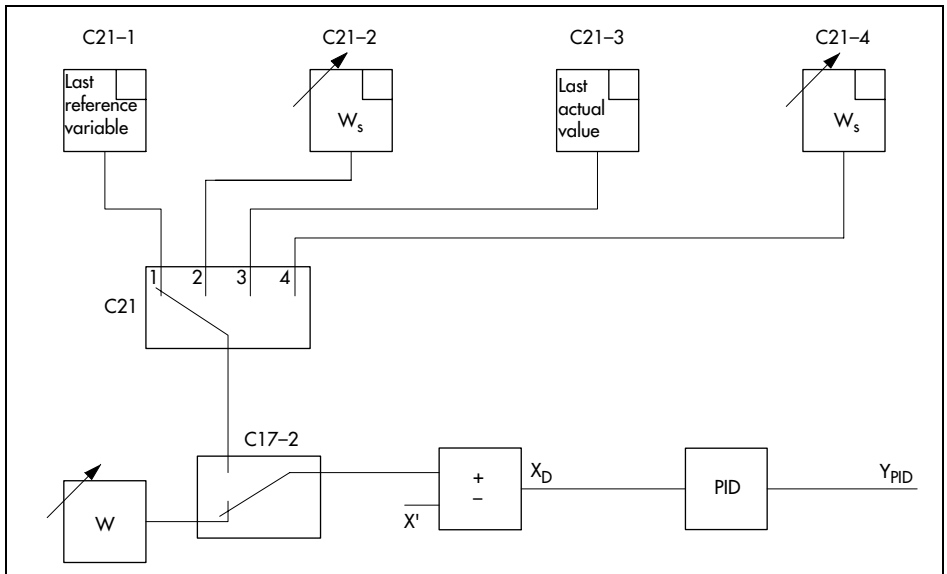

Fig. 11 · Reference variable changeover via binary input

3.9.2 Initialization of reference variable ramp (C17/18/19-3 and C16-2/-4/-5)

The binary input can be used to initiate a reference variable ramp. To do this, select the configuration switch C17-3 and choose the type of reference variable ramp via configuration block C16:

- reference variable ramp with starting condition via C16-2,
- continuous increase or decrease of the reference variable via C16-4 or
- instantaneous increase or decrease of the reference variable via C16-5.

Details concerning the reference variable ramp will be described in section 6.1.

3.9.3 Initialization of output ramp (C17/18/19-4 and C34-4/-5/-11/-12)

When setting the configuration switch C17-4, the binary input can be used to initiate an output ramp. To do this, the configuration switch C34-4, C34-5, C34-11 or C34-12 must additionally be selected. They define an output ramp with starting condition via binary input.

The functioning of the output ramp will be described in section 6.2.

Configuration switch C17-4 can also be used to limit the rate of output changes, see following section.

3.9.4 Limitation of rate of output changes (C17/18/19-4 and C34-6/-7/-8/-13/-14/-15)

When setting the configuration switch C17-4, the binary input bi1 can be used to limit the rate of changes of the output variable. This limitation becomes effective whenever the signal increases, decreases or increases and decreases, depending on whether the configuration switch C34-6, C34-7, C34-8, C34-13, C34-14 or C34-15 is set. For further details, please refer to section 6.2.

The configuration switch C17-4 can also be used to initiate an output ramp with starting conditions via binary input, see previous section.

3.9.5 Initialization of safety output values for controller outputs (C17-5/-6, C18-5/-6, 19-6)

If one of the above configuration switches has been selected and the corresponding binary input is activated, preset output values are provided at the controller outputs. These are the safety output values Y_1K_1 for controller output Y_1 , Y_2K_1 for controller output Y_2 and Y_3K_1 for Y_{PID} output. In limiting control or cascade control mode, the safety output value Y_1K_4 can be applied to the controller output of the limiting or the master controller. The safety output values are adjusted in percent in the parameter level. Section 5.9 will explain the safety output values in detail.

If the configuration switch **C17-5** is selected, the binary input bi1 applies the safety output value Y_1K_1 to the controller output Y_1 .

If the configuration switch **C18-5** is selected, the binary input bi2 applies the safety output value Y_2K_1 to the controller output Y_2 .

A special feature of the configuration switches C17-5 and C 18-5 is that they act directly on the controller output (see Fig. 12 and Fig. 13) and that Y_{PID} is not corrected. As soon as the binary input is closed, the output variable returns to the value calculated by the control algorithm.

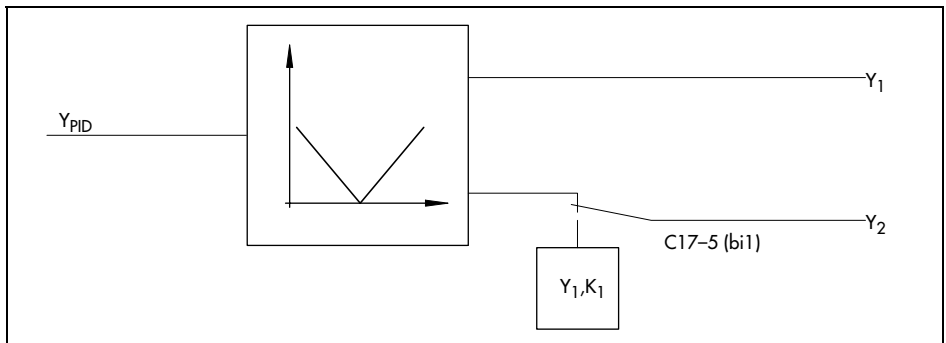

Fig. 13 · Safety output value Y_2K_1 activated by binary input 2

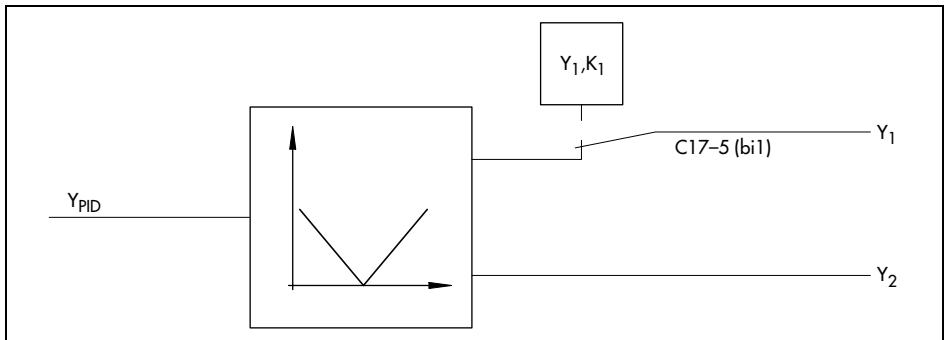

Fig. 12 · Safety output value Y_1K_1 activated by binary input 1

If the configuration switches **C17-5** and **C18-5** are activated simultaneously, the safety output value Y_1K_1 is applied to the controller output Y_1 and Y_2K_1 to controller output Y_2 , provided the binary inputs bi1 and bi2 are open. At the same time, the Y_{PID} output signal assumes the safety output value Y_1K_3 . This function is only effective in the automatic mode.

As soon as the binary input bi1 is closed again, the controller output Y_1 assumes the value determined by Y_1K_3 . The control algorithm starts with this value. The safety output value Y_1K_3 is therefore the starting point for continuing the control process. When the binary input bi2 is closed again, the controller output Y_2 assumes the value determined by Y_1K_3 . This value is the starting point for continuing the control process. The particular feature is that, beginning with the safety output value Y_1K_3 , a ramp-like transfer to the currently calculated output value is produced within 2 seconds.

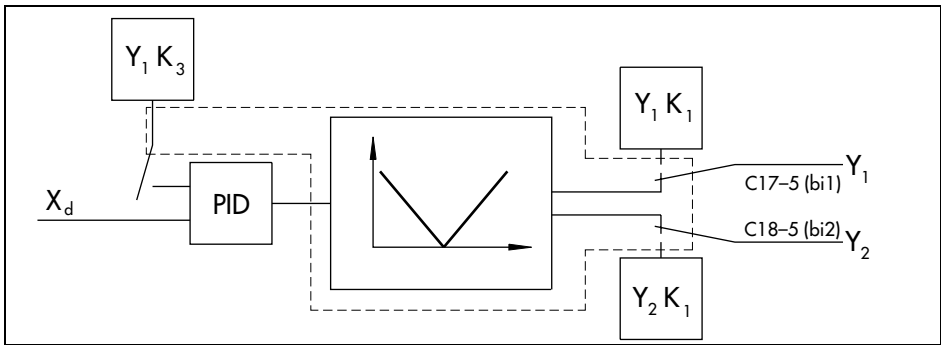

Fig. 14 · Activation of safety output value Y_1K_3

If configuration block **C17-6** has been selected and the process control station runs in automatic mode, the safety output value Y_1K_1 is issued to the controller output Y_1 after the binary input bi1 has been opened. A corresponding process takes place when selecting **C18-6** for bi2 and Y_2K_1 .

Unlike C17-5, the safety output value in this case is influenced by the PID algorithm. This algorithm calculates an Y_{PID} output value in order to obtain Y_1K_1 at the controller output Y_1 . This procedure takes place independent of how the configuration blocks C32 (operating direction of output signals), C33/C35/C36 (limitation of output signals) and C7 (function generation) have been configured (see Fig. 20). The second controller output is set according to the output circuit.

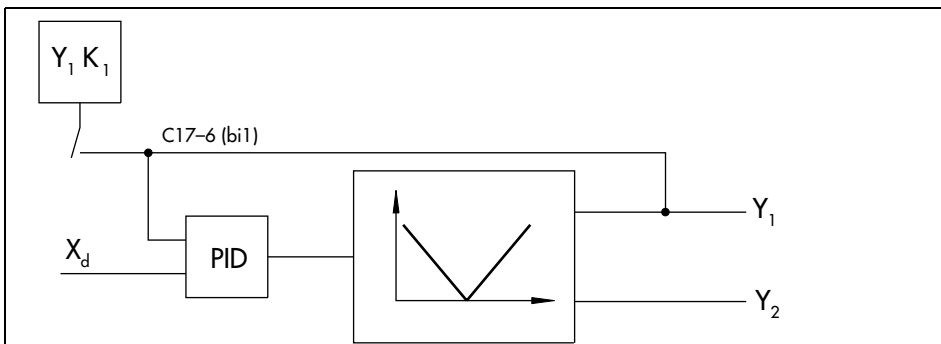

Fig. 15 · Activation of safety output value Y_1K_1 via C17-6 through binary input 1

The configuration switch **C19-6** initiates the safety output value Y_1K_4 at the controller output of the master controller or the limiting controller when the binary input bi 3 opens. This setting is therefore only possible if limiting control or cascade control has been selected (C1-10 or C1-11).

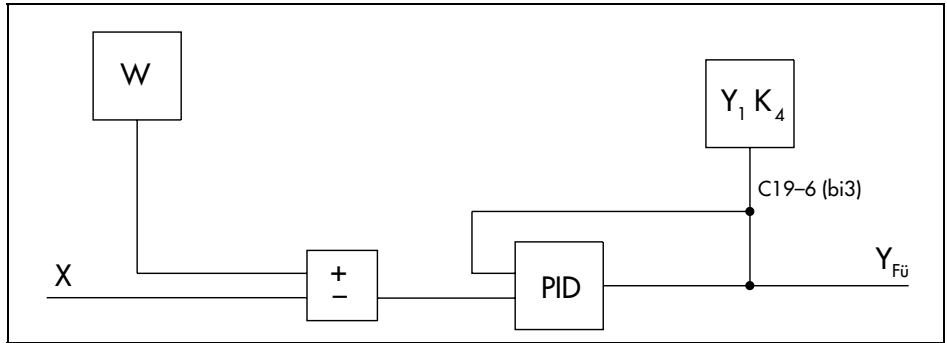

Fig. 16 · Activation of safety output value Y_1K_4

Note:

The safety output value Y_1K_1 has priority over the configuration blocks C33/C35 (limitation of output signals) and C37 (manual/automatic transfer if the measuring range is exceeded or not reached) if activated via binary input bi1. This is also true for the safety output value Y_2K_1 if activated via binary input bi2.

The configuration switches C17-6 and C18-6 cannot be activated at the same time since they lock each other.

3.9.6 Locking of output signals Y_1 and Y_2 (C17/18/19-7)

The configuration switch C17-7 locks the output signals Y_1 and Y_2 when binary input bi1 opens. The respective current output value is maintained at the controller output as long as the binary input is open.

When it is closed again, the locking action is cancelled and control action is continued using the output value calculated last.

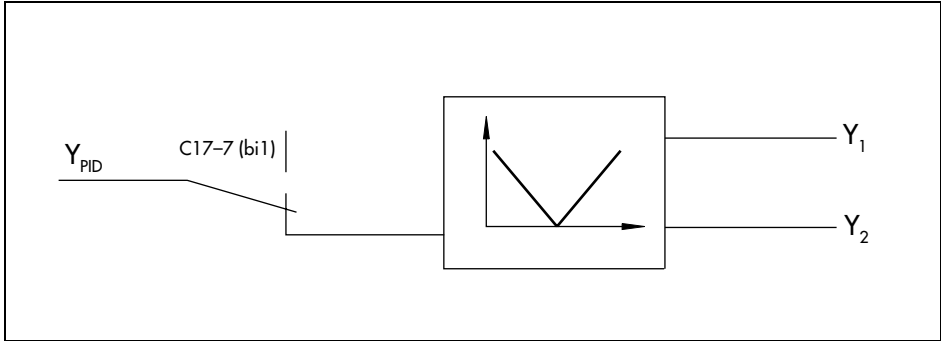

Fig. 17 · Locking of output values Y_1 and Y_2 via binary input 1

3.9.7 Increase or decrease in the actual value (C17/18/19-8)

The configuration switch C17-8 is used to adjust an increase or decrease in the actual value. As soon as the binary input is open, the input signal X (generally the controlled variable) is additively linked with the parameter K_2 . The new actual value is used for control and is shown on the display in the bottom line. As soon as the binary input is closed, the input signal X is used again for control.

In the parameter level, the parameter K_2 is given in percent ranging from -110 to 110 %. When entering e.g. $K_2 = 30$ %, the instantaneous X value will be increased from 50 to 80 %.

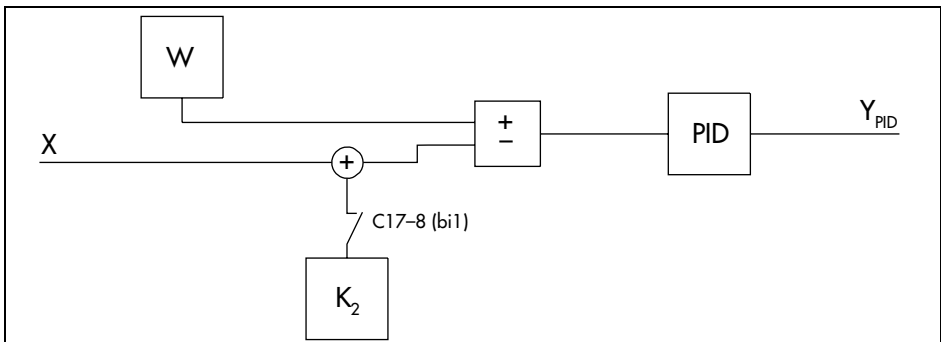

Fig. 18 · Increase or decrease in actual value via binary input 1

3.9.8 Reference variable changeover or changeover to follower controller mode (C17/18/19-9)

The configuration switch C17-9 comprises three different functions, depending on the selected control mode.

When selecting **follow-up control** with internal/external reference variable changeover (FO2, C1-5) or ratio control with internal/external ratio default (RC2, C1-8), this function changes over from one reference variable to the other (see Fig. 19). The key (B) is locked as long as this function is active.

When selecting **cascade control** (CA1 via C1-10 or CA2 via C1-11), the process control station changes over to follower controller mode as soon as the binary input is open, i. e. the cascade is interrupted (see Fig. 20). The follower controller data are presented on the display. The key (B) is locked. After the binary input has closed, the master and the follower controller are connected again to form a cascade. Now the master controller data are presented on the display.

When selecting **limiting control** (C1-10 or C1-11, and C33-12/13/14/15), the binary input causes the display of the process control station to change between limiting controller and primary controller.

This configuration switch cannot be selected in the other control modes.

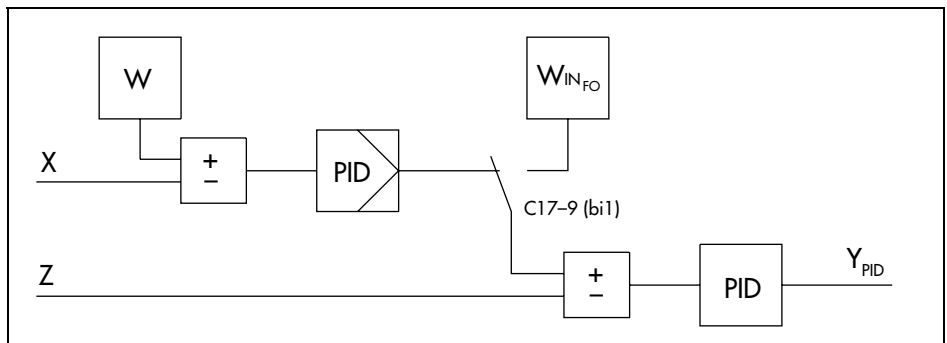

Fig. 20 · Changeover to follower controller mode via binary input 1

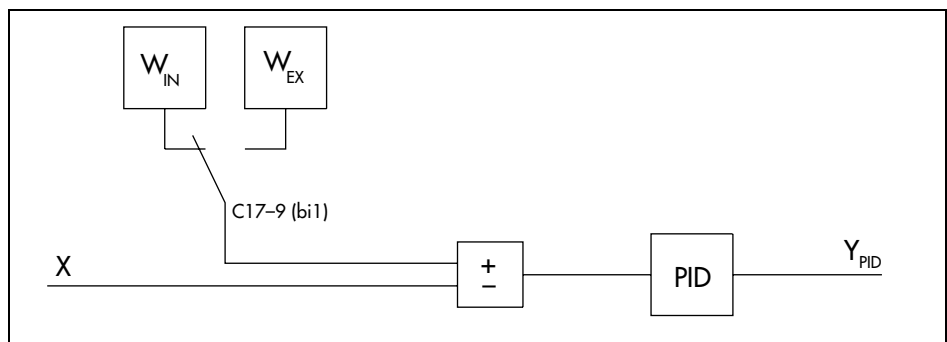

Fig. 19 · Reference variable changeover via binary input 1

3.9.9 Changeover to manual mode (C17/18/19-10)

The configuration switch C17-10 is used to switch from automatic mode to manual mode when the binary input is open.

After this changeover has been carried out, the manual/automatic transfer switch (E) is locked until the binary input is closed and the automatic mode is in effect again as a result of this.

If the process control station has been changed to manual mode by the key (E), the binary input is inactive until the key (E) is used again to change to automatic mode.

3.9.10 Changeover to position correction (C17/18/19-11)

The configuration switch C17-11 switches from automatic or manual mode to position correction when the binary input is open.

When selecting this function, the symbol \square representing the external output signal is shown on the display right beside the bar symbol representing the output variable. If position correction is activated by binary input, a black \blacksquare is then added under the symbol \square on the display. The symbol representing automatic or manual mode is hidden.

Position correction is not initiated if the safety output values Y_1K_1 or Y_2K_1 (see chap. 3.9.5) or the locking of output signals (s. Kap. 3.9.6) is activated.

Position correction causes the signal Y'_{ACTUAT} to be taken as new output value. This is also called Y-tracking. The Y'_{ACTUAT} value, however, does not directly act on the controller output, but passes through the entire output circuitry. This allows the configuration blocks C32 (operating direction of output signals), C33/C35/C36 (limitation of output signals) and C7 (function generation) to be used in order to affect the output value in such a way that a modified Y'_{ACTUAT} value is produced at the output.

Position correction is deactivated by closing the binary input. Then, the output value calculated by means of the PID algorithm is used again for control.

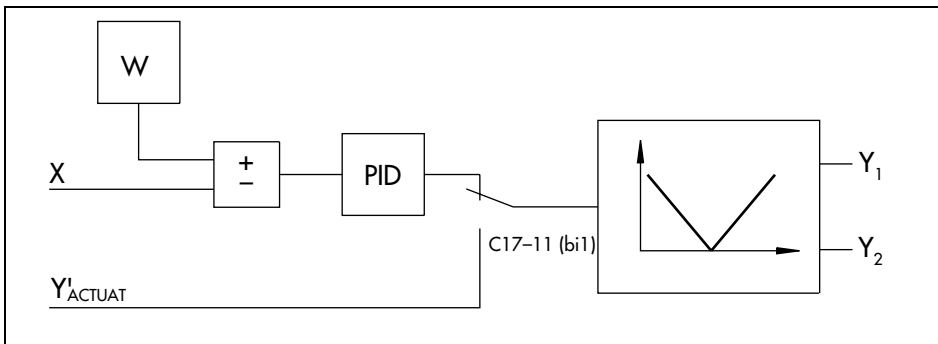

Fig. 21 · Changeover to position correction

3.9.11 Locking of manual mode when measuring range monitoring function is activated (C17/18/19-12)

The configuration switch C17-12 is used to prevent changeover to manual mode in case signals are outside the measuring range, provided that measuring range monitoring has been activated via configuration block C15>1 and that changeover to manual mode, in case signals are outside the measuring range, has been set C37>1.

Changeover to manual mode is prevented, if the binary input was open before the measuring range has been exceeded or not reached.

If the binary input is closed during the time signals are outside the measuring range, the locking function will be cancelled. The process control station changes over to manual mode according to the settings in configuration block C37.

However, if the measuring range is not exceeded in any way during the closing of the binary input, the process control station remains in the automatic mode.

3.9.12 Changeover of digital displays to definition of C4-1 (C17/18/19-13)

The configuration switch C17-13 allows using the binary input bi1, serving as a means to switch between the two digital display settings without modifying the setting of the configuration block C4 in the configuration level.

When the binary input opens, the current display is replaced by the display according to C4-1. When the binary input closes, the display set in configuration block C4 appears again.

What can be done with the different displays will be described in section 8.1.

3.9.13 Activation of limit relay G1 or G2 (C17/18-14)

When selecting the configuration switch C17-14, the binary input bi1 is enabled to operate the limit relay G1. The same is true for bi2, C18-14 and G2, correspondingly.

The configuration blocks C40 and/or C41 which determine the assignment of the limit relays are now reset and cannot be selected anymore. The limit relays can only be operated by the binary input. The limit relay is activated when the binary input opens. The closing binary input resets the limit relay.

For further details on configuration of limit relays, please refer to section 5.6.

3.9.14 Locking of operator keys and/or protection against unauthorized modification of configuration and parameter data (C19-14, C59)

The binary input bi3 initiates the settings of the configuration block C59, if C19-14 has been set earlier. C59 enables the user to protect the configuration and parameter level against unauthorized modification and/or to lock the operator keys of the process control station. C59 can only be set if C19-14 has been selected before.

C59-1 does not enable protection of the configuration or parameter level or the locking of operator keys.

If **C59-2** is selected and bi3 is open, all operator keys of the process control station are locked until the binary input bi3 is closed. The RS-232 interface on the front panel and also the RS-485 interface can be used to carry out modifications concerning configuration and parameterization.

If **C59-3** is selected and bi3 is open, no modifications can be carried out in the configuration and parameter level. These limitations also apply to the RS 485 interface. Only the interface on the front panel accepts modifications regarding configuration and parameterization.

The setting **C59-4** and the open binary input bi3 lock the operator keys as described for C59-2. In contrast to C59-2, however, this setting does not allow carrying out modifications regarding configuration and parameterization via RS-485 interface. This can only be done via RS-232 interface on the front panel.

Note!

The configuration and parameter levels can also be protected against alteration by means of a code number. Refer to sections 6.10 and 6.11 in EB 6412 EN on how to determine these code numbers.

3.9.15 Initialization of change of control action (C17/18/19-15, C29-8/9/10)

The configuration switch C17-15 is used to activate and deactivate the change of control action via binary input, depending on whether C29-8, C29-9 or C29-10 is set.

When the binary input is activated, the change of control action is also active. It is not active with a closed binary input.

Please refer to section 7.7 for further details on change of control action.

4 Control modes

Control modes are specified by the configuration block C1. The control modes available with the process control station are fixed set point control (FSP), follow-up control (FO1, FO2), ratio control (RC1, RC2), synchro control (SY) and finally limiting or cascade control (CA1, CA2). This configuration block must be set first since all the other configuration blocks of the process control station are reset to factory default upon modification of the control mode.

The following sections present to you each possible control mode. The internal input signals used will be introduced. After they have passed the input circuitry, they are designated X' , W'_{EX} , Z' and Y'_{ACTUAT} . The parameters to be set in the parameter level are also listed in this section.

Disturbance variables can be processed in any control mode. You will find in section 4.6 how to deal with these options.

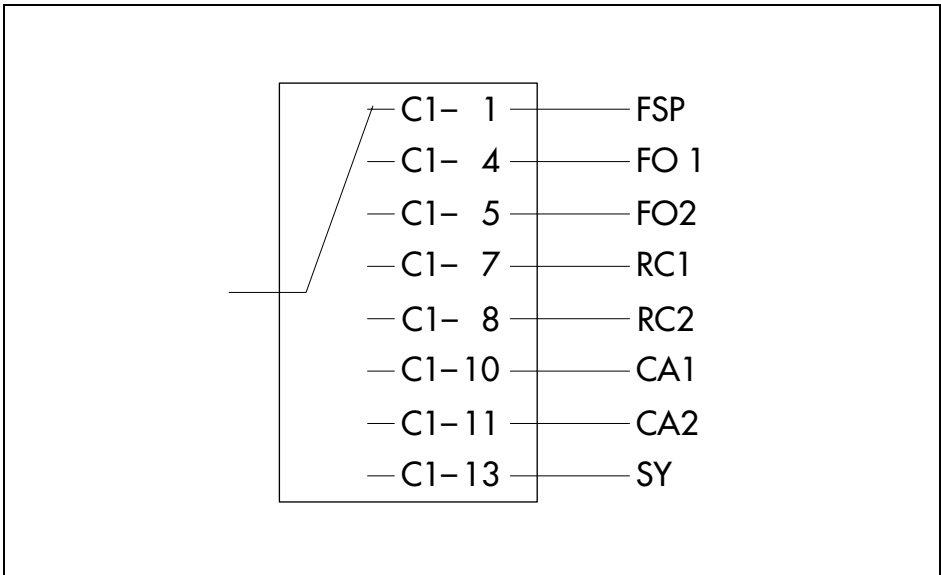

Fig. 22 · Control modes

4.1 Fixed set point control (C1-1)

Fixed set point control (FSP) is selected via configuration switch C1-1.

In fixed set point control, the reference variable is constant over time, therefore, the internal reference variable W_{IN} is used. This variable can be modified in the parameter level or also in the operating level via keys (C) and (D). As far as C22-3 is concerned, it would be useful to refer to section 7.2.

The controlled variable is the input signal X' .

The input signals W'_{EX} and Z' may be used for feedforward control, see section 4.6.1.

Reference variable changeover via key (B) is not possible.

Parameters to be set

W_{IN} , $W_{IN}\simeq$, $W_{IN}\sphericalangle$	Measuring range of internal reference variable, generally identical with the measuring range of input X'
$X\simeq$, $X\sphericalangle$	Measuring range for input signal X'
K_1	Operating point (only for P/PD algorithm)
$K_P K_3$	K_P value for PD_2 element, see section 4.6.1
$T_V K_3$	T_V value for PD_2 element, see section 4.6.1

Attention!

If the control mode is changed, all other configuration blocks will be reset to factory default!

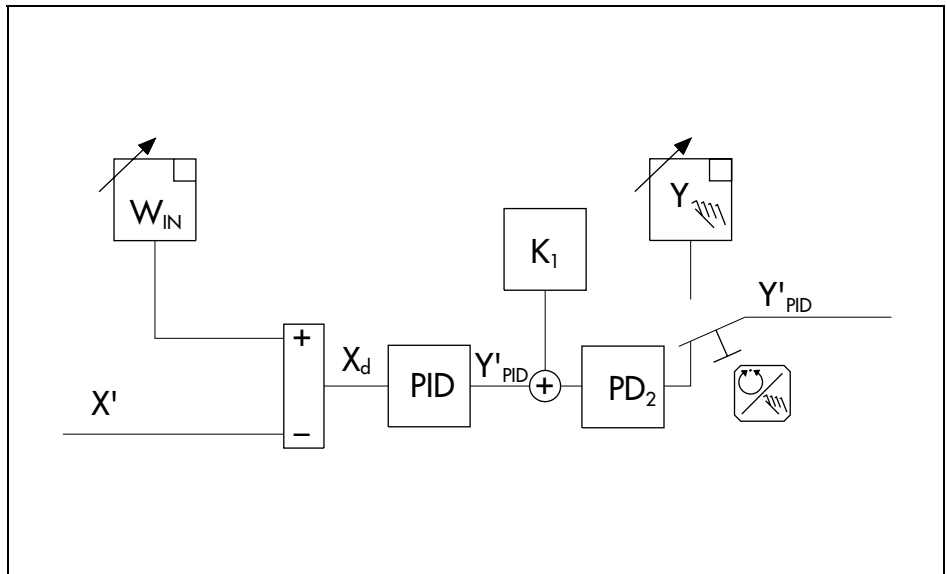

Fig. 23 · Fixed set point control

4.2 Follow-up control (C1-4/5)

Follow-up control can be selected either with external reference variable (FO1) or with internal/external reference variable changeover (FO2). The external reference variable W_{EX} depends on a measured variable which changes over time.

The configuration switch **C1-4** activates follow-up control with external reference variable (FO1). The key (B) cannot be used. The internal reference variable cannot be selected.

Follow-up control with external/internal reference variable changeover (FO2) is selected via configuration switch **C1-5**. The key (B) can be used to switch from one reference variable to the other. The internal reference variable is adjusted via keys (C) and (D) or in the parameter level. As far as C22-3 is concerned, it would be useful to refer to section 7.2.

The external reference variable is the input signal W'_{EX} .

The external reference variable is represented by the symbol \square and is displayed to the right of the symbol representing the reference variable. If the internal reference variable is activated, the symbol \blacksquare appears below the two other symbols.

For both types of follow-up control, the input signal X' serves as controlled variable.

The input signal Z' can be used for feedforward control, see section 4.6.3

Parameters to be set

W_{IN} , $W_{IN}\sphericalangle$, $W_{IN}\sphericalright$	Measuring range of internal reference variable, generally identical with the measuring range of input X'
$X\sphericalangle$, $X\sphericalright$	Measuring range for input signal X'
$W_{EX}\sphericalangle$, $W_{EX}\sphericalright$	Measuring range for input signal W'_{EX}
K_1	Operating point (only for P/PD algorithm)
$K_P K_3$	K_P value for PD ₂ element, see section 4.6.1
$T_V K_3$	T_V value for PD ₂ element, see section 4.6.1

Attention!

If the control mode is changed, all other configuration blocks will be reset to factory default!

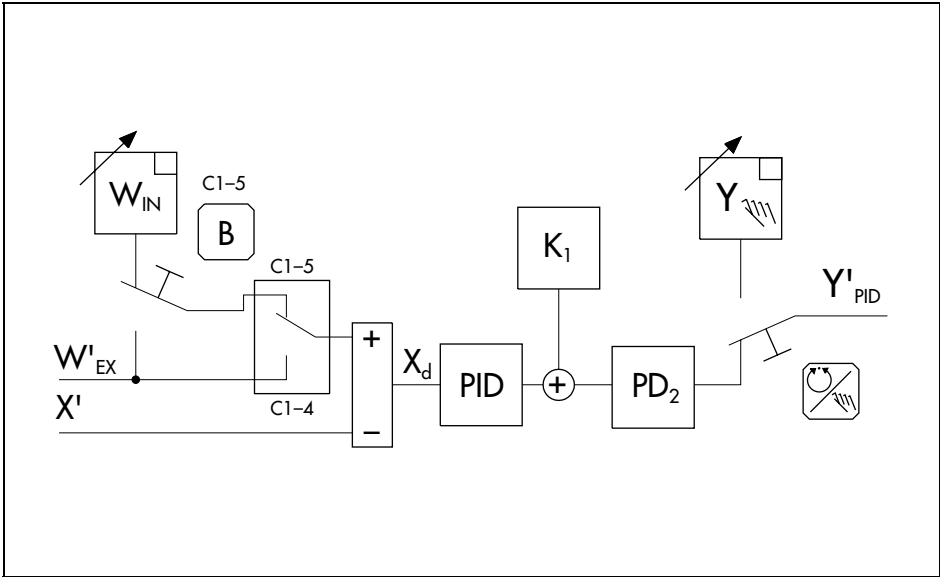

Fig. 24 · Follow-up control

4.3 Ratio control (C1-7/8)

Ratio control can be selected as to have an internal ratio (RC1) or an internal/external ratio changeover (RC2). In this control mode, it is not the absolute value of a controlled variable which is controlled but the ratio V between two variables. These are the input signal W'_{EX} as leading variable and the input signal X' as second variable.

Ratio control with internal ratio (RC1) is selected via configuration switch **C1-7**.

Ratio control with internal/external ratio changeover (RC2) is activated by **C1-8**. The key (B) is used to switch between the internal and external ratio.

The internal ratio is determined by the parameter W_{IN} . This ratio can be adjusted between 0.00 and 19.99 via keys C and D or adjustment may be made in the parameter level. For C22-3, it would be useful to refer to section 7.2.

The external ratio is determined by the input variable Z' and can also be adjusted in the range from 0.00 to 19.99.

The parameter K_5 can carry out zero shift. K_5 is given in percent of the W_{EX} measuring range.

The relationship, with the ratio V being either W_{IN} or Z' , is as follows:

$$V = \frac{X - K_5}{W_{EX}}$$

The external ratio is represented by the symbol \square and is displayed to the right of the reference variable symbol. If the internal ratio is in effect, the additional symbol \blacksquare appears.

The input signal Y'_{ACTUAT} , and for RC1, this may also be Z' , can be used for feedforward control, see section 4.6.4

Parameters to be set

W_{IN} , $W_{IN}\simeq$, $W_{IN}\sphericalangle$	Measuring range of internal ratio (0.00 to 19.99)
$X\simeq$, $X\sphericalangle$	Measuring range for input signal X'
$W_{EX}\simeq$, $W_{EX}\sphericalangle$	Measuring range for input signal W'_{EX}
$Z\simeq$, $Z\sphericalangle$	Measuring range for input signal Z' (0.00 to 19.99)
K_1	Operating point (only for P/PD algorithm)
K_5	Constant for zero shift
$K_P K_3$	K_P value for PD_2 element, see section 4.6.1
$T_V K_3$	T_V value for PD_2 element, see section 4.6.1

Attention!

If the control mode is changed, all other configuration blocks will be reset to factory default!

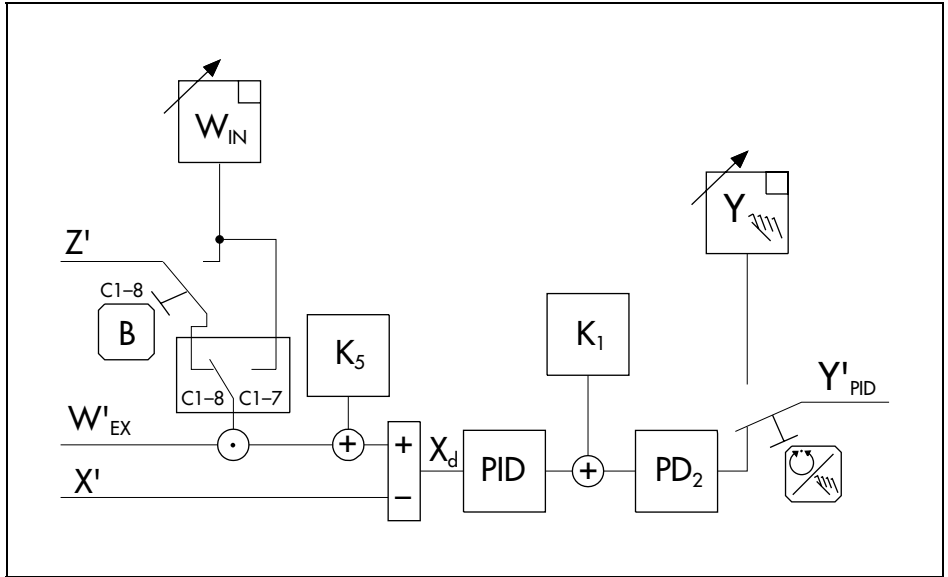

Fig. 25 · Ratio control

4.4 Cascade control modes (C1-10/11)

4.4.1 Cascade control

Cascade control with internal reference variable (CA1) is selected by configuration switch C1-10, whereas cascade control with external reference variable (CA2) is selected via C1-11.

In this control mode, the master controller as well as the follower controller of a cascade are both included in the TROVIS 6412 or 6442 Process Control Stations. To be able to do this, the displays and also the keys (C) and (D) have a double function. The key (B) is used to interrupt or close the cascade.

When the cascade is interrupted, only the follower controller is in operation. The interrupted cascade is indicated by a black quad to the right of the reference variable symbol. In this case, the reference variable and the controlled variable of the follower controller are displayed. The keys (C) and (D) are used to change the internal reference variable of the follower controller. The controlled variable for the follower controller is the input signal Z' .

When the cascade is closed, the reference variable and the controlled variable of the master controller are displayed. The black quad next to the reference variable symbol is now hidden. Depending on the configuration, the master controller operates on an external (input signal W'_{EX}) or on the internal reference variable W_{IN} . The latter can be changed via keys C and D, unless C22-3 has been selected, in this case, see section 7.2. The output signal of the master controller makes up the reference variable of the follower controller. This signal constantly overwrites the internal reference variable W_{IN} of the follower controller.

The input signal Y'_{ACTUAT} , and for cascade control with internal reference variable (C1-10), this may also be W'_{EX} , can be used for feedforward control, see section 4.6.5

Parameters to be set

This control mode operates on two sets of parameters. The master controller works with the parameter set PA1, the follower controller with PA2. PA1 and PA2 appear in the parameter level instead of PA.

$W_{IN}, W_{IN}\blacktriangleleft, W_{IN}\blacktriangleright$	PA1	Measuring range of internal reference variable, measuring range generally identical with that of input X'
$X\blacktriangleleft, X\blacktriangleright$	PA1	Measuring range for input signal X'
$W_{EX}\blacktriangleleft, W_{EX}\blacktriangleright$	PA1	Measuring range for input signal W'_{EX}
$Y_1\blacktriangleleft, Y_1\blacktriangleright$	PA1	Output variable range of master controller
K_1	PA2	Operating point (only for P/PD algorithm)
$Z\blacktriangleleft, Z\blacktriangleright$	PA2	Measuring range for input signal Z' , (controlled variable for follower controller)
$K_P K_3$	PA2	K_P value for PD ₂ element, see section 4.6.1
$T_V K_3$	PA2	T_V value for PD ₂ element, see section 4.6.1

Attention!

If the control mode is changed, all other configuration blocks will be reset to factory default!

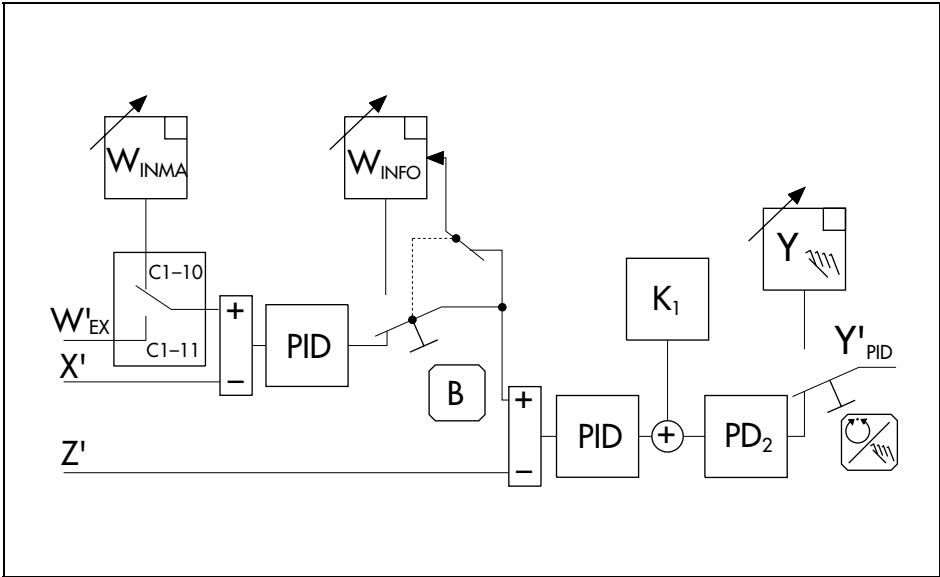

Fig. 26 · Cascade control

4.4.2 Modification of the follower controller reference variable for cascade control

In cascade control mode (CA1 and CA2), the reference variable of the follower controller can additionally be included in control. To obtain this subfunction of cascade control, you have to select the configuration switch C22≥9. In a closed cascade, there are the following possibilities to influence the reference variable of the follower controller (W_{FO}):

Y_{MA}	Output variable of the master controller, which at the same time is the reference variable of the follower controller;
$W_{IN_{FO}}$	Internal reference variable of the follower controller
W_{FO}	New reference variable of the follower controller
C22-9	$W_{FO} = Y_{MA} + W_{IN_{FO}}$
C22-10	$W_{FO} = Y_{MA} - W_{IN_{FO}}$
C22-11	$W_{FO} = W_{IN_{FO}} - Y_{MA}$
C22-12	$W_{FO} = W_{IN_{FO}}$, if $W_{IN_{FO}} > Y_{MA}$ $W_{FO} = Y_{MA}$, if $Y_{MA} > W_{IN_{FO}}$
C22-13	$W_{FO} = W_{IN_{FO}}$, if $W_{IN_{FO}} < Y_{MA}$ $W_{FO} = Y_{MA}$, if $Y_{MA} < W_{IN_{FO}}$

Parameters to be set, see section 4.4.1 and in addition:

W_{IN} , $W_{IN_{\sphericalangle}}$, $W_{IN_{\sphericalast}}$	PA2 Measuring range of internal reference variable of the follower controller
--	---

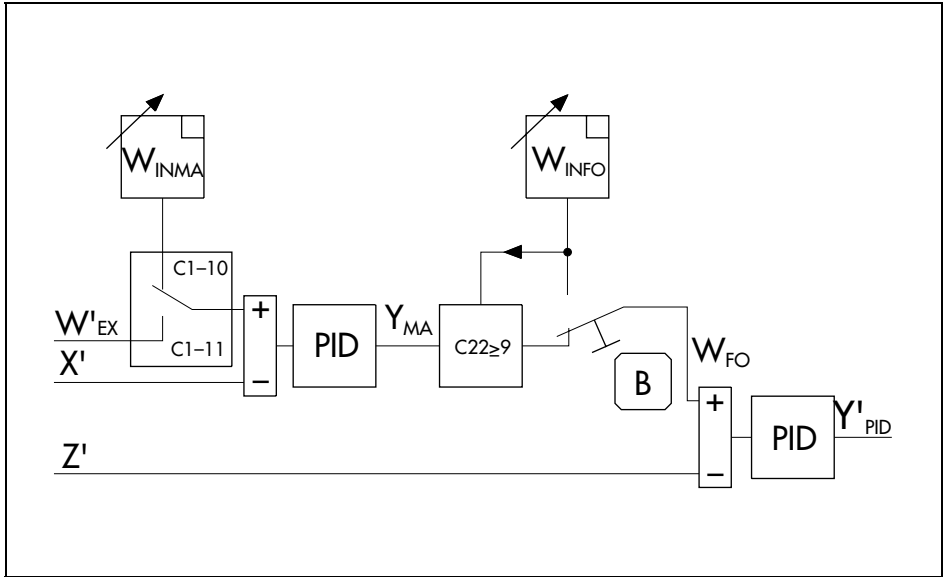

Fig. 27 · Modification of follower controller reference variable for cascade control

4.4.3 Limiting control

Limiting control is activated as a subfunction of cascade control via configuration switch C1-10 (CA1, cascade control with internal reference variable) or via C1-11 (CA2, cascade control with external reference variable) in combination with configuration switch C33 \geq 8.

In this control mode, both the limiting controller as well as the primary controller of a cascade are both included in the TROVIS 6412 or 6442 Process Control Stations. The key B is used to switch between limiting controller and primary controller. The primary controller data are represented by the symbol ■ which is displayed on the top right.

Limiting control is used to control a process variable, with a second process variable being limited to a predetermined value. Both process variables are modified by the same final control element and, therefore, physically depend on each other. It is either the smaller or the larger output signal which is effective. An example for limiting control is flow control in a plant where the prevailing pressure must not exceed a predetermined value. For this purpose, two controllers must act on the same final control element.

When selecting the configuration switches **C33-8 to C33-13**, the output variable of the primary controller is limited by the output variable of the limiting controller to a certain minimum and maximum value. However, the limiting controller is not influenced by the primary controller. C33-8 to C33-13 specify, whether Y_1 , Y_2 or Y_{PID} of the limiting controller determine the lower or the upper limit for Y_{PID} of the primary controller.

The configuration switches **C33-14** (selection of minimum output variable) or **C33-15** (selection of maximum output variable) mutually determine the limits of the output variable. The smallest or the largest output variable is selected respectively. The selection of the maximum output variable consists of limiting the minimum output variable Y_{\leq} , whereas selecting the minimum variable consists of limiting the maximum output variable Y_{\geq} . In the automatic mode, the parameters Y_{\leq} and Y_{\geq} represent the absolute limits of the output variables. For C33-14 and C33-15, it is necessary to additionally define the parameter X_{SDY1} . It specifies the differential gap when the output variable is switched between primary and limiting controller.

The controlled variable for the limiting controller is the input signal X' . The limiting controller is either a fixed set point controller (C1-10) or a follower controller (C1-11). It operates on the parameter set PA1. The parameter K_1 can be used to specify an operating point or an Y rate action.

The controlled variable for the primary controller is the input signal Z' . The primary controller is a fixed set point controller using the parameter set PA2. The parameter K_1 can be used to specify an operating point or an Y rate action.

The input variable Y'_{ACTUAT} , and in limiting control mode with internal reference variable (C1-10), this may also be W'_{EX} , can be used for feedforward control.

Parameters to be set

W_{IN} , $W_{IN\leq}$, $W_{IN\geq}$	PA1	Meas. range of internal reference variable, only for C1-10
X_{\leq} , X_{\geq}	PA1	Meas. range for input signal X'
$W_{EX\leq}$, $W_{EX\geq}$	PA1	Meas. range for input signal W'_{EX} , only for C1-11
$Y_{1\leq}$, $Y_{1\geq}$	PA1	Output variable range of limiting controller
X_{SDY1}	PA1	Differential gap, only for C33-14/15
W_{IN} , $W_{IN\leq}$, $W_{IN\geq}$	PA2	Meas. range of internal reference variable of primary controller
Z_{\leq} , Z_{\geq}	PA2	Meas. range for input signal Z' , (controlled variable of primary controller)
$K_P K_3$, $T_V K_3$	PA2	K_P , T_V value for PD_2 element, see section 4.6.1

Attention!

If the control mode is changed, all other configuration blocks will be reset to factory default!

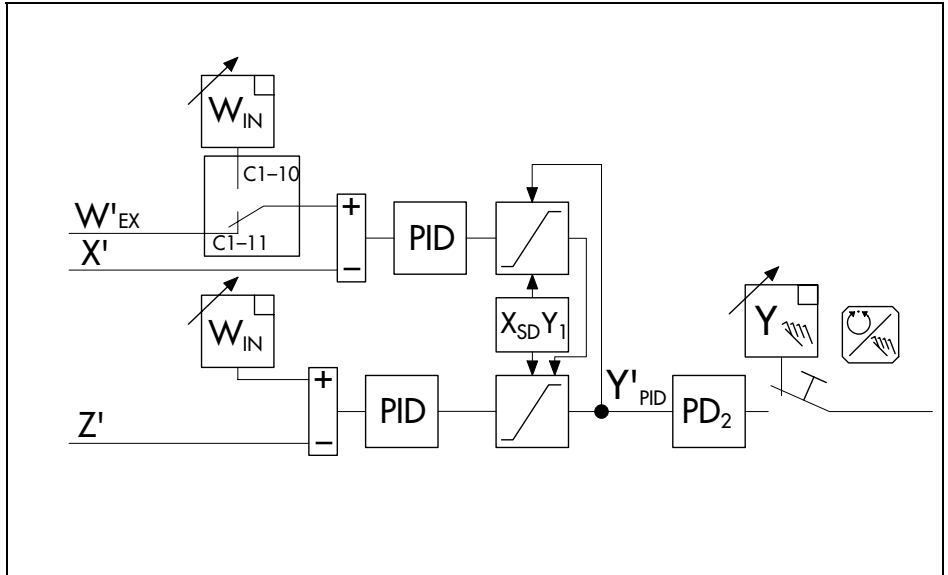

Fig. 29 · Limiting control with selection of either minimum or maximum output variable via C33-14/15

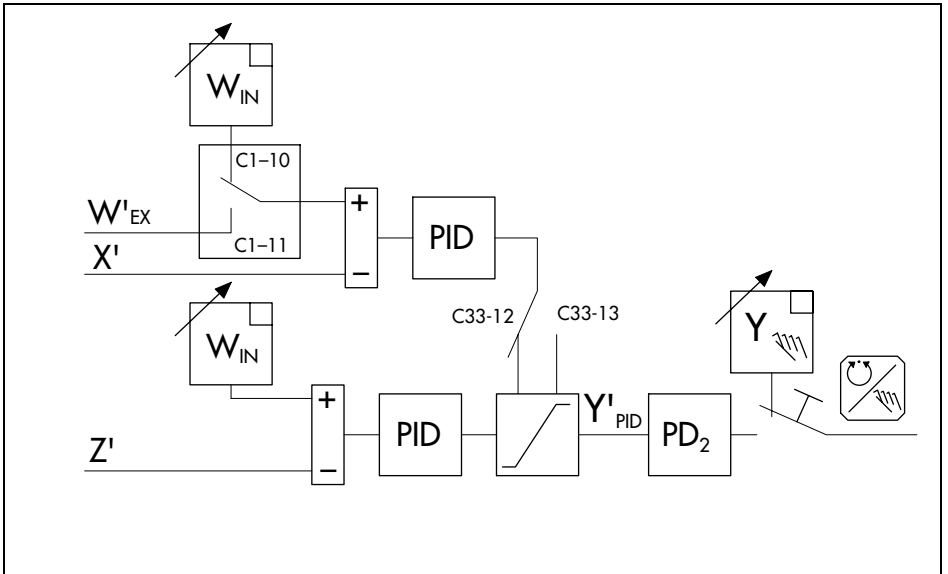

Fig. 28 · Limiting control with limited Y_{PID}

4.5 Synchro control (C1-13)

The configuration switch C1-13 is used to activate synchro control (SY).

In synchro control, different control loops have the same reference variable which, however, can be influenced by certain constants in each individual control loop. These constants are the parameters K_5 and K_1W_{EX} for TROVIS 6412/6442. K_5 can be used to subtract an offset value. K_1W_{EX} multiplies the reference variable.

To calculate the reference variable, use the following equation:

$$W' = (W_{EX} - K_5) \cdot K_1 W_{EX}$$

The input signal W'_{EX} is processed as reference variable, whereas the input signal X' is processed as controlled variable.

The input variables Y'_{ACTUAT} and Z' can be used for feedforward control, see section 4.6.7.

Parameters to be set

X_{\neq}, X_{\neq}	Measuring range for input signal X'
$W_{EX\neq}, W_{EX\neq}$	Measuring range for input signal W'_{EX}
K_1	Operating point
K_5, K_1W_{EX}	Constants for linking with input signal W'_{EX}
K_pK_3, T_VK_3	K_p value, T_V value for PD_2 element, see section 4.6.1

Attention!
If the control mode is changed, all other configuration blocks will be reset to factory default!

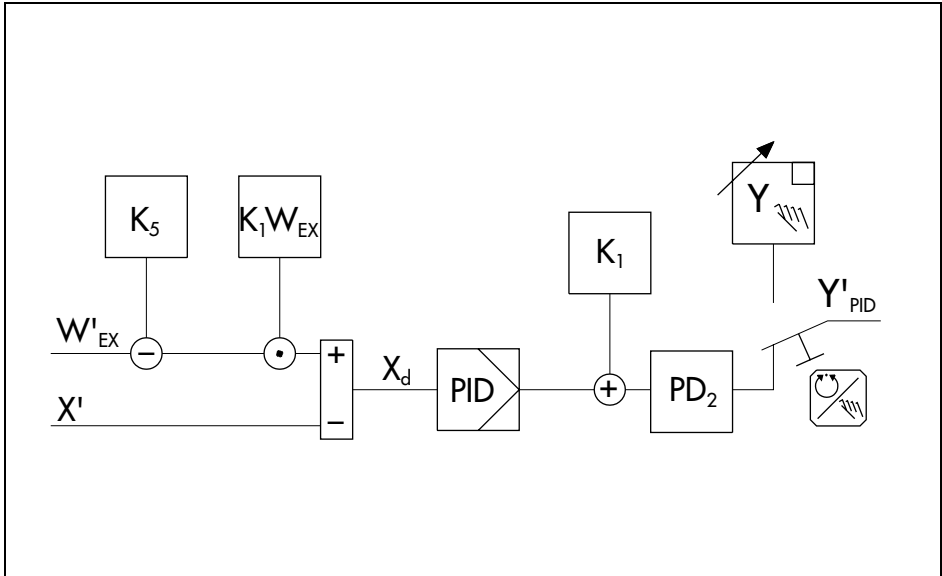

Fig. 30 · Synchro control

4.6 Feedforward control (C2)

Feedforward control improves the control quality of the controlled system. However, a prerequisite for feedforward control is that the disturbance variable(s) can be measured. The TROVIS 6412 Process Control Station allows to use free inputs for feedforward control and to feed it to the input or output of the controlled system in order to influence the controlled system whenever the disturbance variables change. Depending on the control mode, there are various solutions to link the disturbance variables in the process control station.

In the following sections, feedforward control will be described for each control mode individually. It is especially recommended to pay attention to the Figs. **presenting the individual solutions of connection**.

Feedforward control is generally activated by the configuration blocks C2, C3 and C8.

The configuration block C2 is used to determine whether feedforward control is to be selected. If so ($C2 > 1$), the next step will be to determine which variables are to be linked and if the disturbance variables should act on the input, on the output or on both. Factory default of the process control station is without feedforward control, this is C2-1.

The configuration block C3 defines the calculation specification and the mathematical sign. The configuration table (see Appendix A) for this configuration block includes two columns, one containing the sign of the arithmetic element, the second containing the disturbance variable. The mathematical sign of the arithmetic element refers to the sign in the formulas below in which the signal Z' , W'_{EX} and Y'_{ACTUAT} are linked:

$$\pm (Z' + K_9 \cdot Y'_{ACTUAT} - K_3) \cdot K_4.. \text{ For C3-1 to C3-8: } (Z' + K_9 \cdot Y'_{ACTUAT} - K_3) \geq 0$$

$$\pm (K_9 \cdot Y'_{ACTUAT} - K_3) \cdot K_4.. \text{ For C3-1 to C3-8: } (K_9 \cdot Y'_{ACTUAT} - K_3) \geq 0$$

$$\pm (W'_{EX} + K_9 \cdot Y'_{ACTUAT} - K_3) \cdot K_4.. \text{ For C3-1 to C3-8: } (W'_{EX} + K_9 \cdot Y'_{ACTUAT} - K_3) \geq 0$$

The calculation specification (addition, subtraction, multiplication or division) for the disturbance variable must always be employed where C3 is included in the Figs.

The configuration block C8 specifies in which way the input variables are to be linked with each other. The configuration switches C8-2 to C8-6 link the input variable X' with the signal A. The signal A results from the connection of the input variables which are used as disturbance variable signals. Closer details may be found in the Figs. **and are described with the different control modes**.

C8-1 links the signal A with the input signal X' (controlled variable) by addition.

C8-2 links the signal A with the input signal X' by subtraction.

C8-3 links the signal A with the input signal X' by multiplication.

C8-4 links the signal A with the input signal X' by mean-value generation.

C8-5 activates selection of the minimum variable of X' and A.

C8-6 s selection of the maximum variable of X' and A.

C8-7 links the inputs X' , W'_{EX} and Z' with each other according to the calculation specification B.

$$\text{The latter results from: } B = K_2 + K_1 W'_{EX} \cdot W'_{EX} \cdot \frac{K_1 X \cdot X' + K_1 Z \cdot Z'}{K_2 X \cdot X' + K_2 Z \cdot Z'}$$

C8-7 can only be selected in fixed set point control mode.

The signals A and B can be further influenced by various parameters. These are described with the individual control modes and can be seen from the Figs.

Another possibility of influencing known disturbance variables is offered by the PD elements PD₁ and PD₂. They are selected via configuration block C50. For further details, please refer to section 4.6.1.

4.6.1 Dynamic behavior of PD elements (C50)

The configuration block C50 specifies the dynamic behavior of two PD elements. They help to compensate the dynamic disturbance variables. The PD element PD₁ is located in the input area ahead of the configuration block C2. It is only active if feedforward control has been selected via C2. The other PD element PD₂ is installed in the output area and is always active. The PD elements are illustrated in the Figs. **accompanying the individual control modes**.

The configuration block C50 can be used to specify P or PD action for both PD elements individually. Factory default is C50-1, i.e. both PD elements are set to P action. The other possible combinations can be seen from the configuration table in Appendix A .

The PD elements are defined by the parameters K_PK₂ (K_P value) and T_VK₂ (T_V value) for PD₁ as well as K_PK₃ (K_P value) and T_VK₃ (T_V value) for PD₂

Parameters to be set

K _P K ₂	K _P value for PD ₁ element
T _V K ₂	T _V value for PD ₁ element
K _P K ₃	K _P value for PD ₂ element
T _V K ₃	T _V value for PD ₂ element

4.6.2 Fixed set point control with feedforward control

Fixed set point control is activated via configuration switch C1-1, as described in section 4.1. W'_{EX}, Z' and Y'_{ACTUAT} are available for feedforward control. However, feedforward control must be set via configuration blocks C2, C3 and C8. The options possible for fixed set point control are illustrated in Fig. 31 , Fig. 32 and Fig. 33 .

The following parameters are used to increase or decrease and multiply the input variables W'_{EX}, Z' and Y'_{ACTUAT} by a certain factor:

The input variable W'_{EX} can be linked with the parameter **K₅** by multiplication and with **K₇** by addition. The newly generated signal is designated W''_{EX} in the Figs.

The input variables Z' and Y'_{ACTUAT} are linked with each other by the formula $\pm(Z' + K_9 \cdot Y'_{ACTUAT} - K_3) \cdot K_4$. The parameter **K₉** multiplies the input variable Y'_{ACTUAT} by a certain factor. Z' and the multiplied input variable Y'_{ACTUAT} are then added up. The parameter **K₃** decreases the resulting signal. Finally, the parameter **K₄** multiplies the resulting signal by a certain factor. The mathematical sign for the formula mentioned above is determined by the configuration block C3, see section 4.6 (Note: For C3-1 to C3-8, the following applies to the contents in parentheses $(Z' + K_9 \cdot Y'_{ACTUAT} - K_3) \geq 0$). The newly generated signal is designated Z'' in the Figs.

When selecting the configuration switches C2-2, C2-3, C2-5 or C2-9, the modified input variables W''_{EX} and Z'' are added up to form the signal A (Fig. 31). **C2-2 and C2-9** link A with the controlled variable X', **C2-5** links A with the reference variable W_{IN}, **C2-3** links A with the output of the process control station.

The configuration switches C2-2 and C2-9 partly differ from each other as to the type of linking with X'. **C2-2** is defined by the configuration switches C8-1 to C8-6.

C8-4 activates mean-value generation, **C8-5** activates selection of minimum output variable between X' and A, whereas **C8-6** selection of maximum output variable between X' and A. **C2-9** is defined by configuration block C3. **C3-7, C3-8, C3-12** divides X' by A.

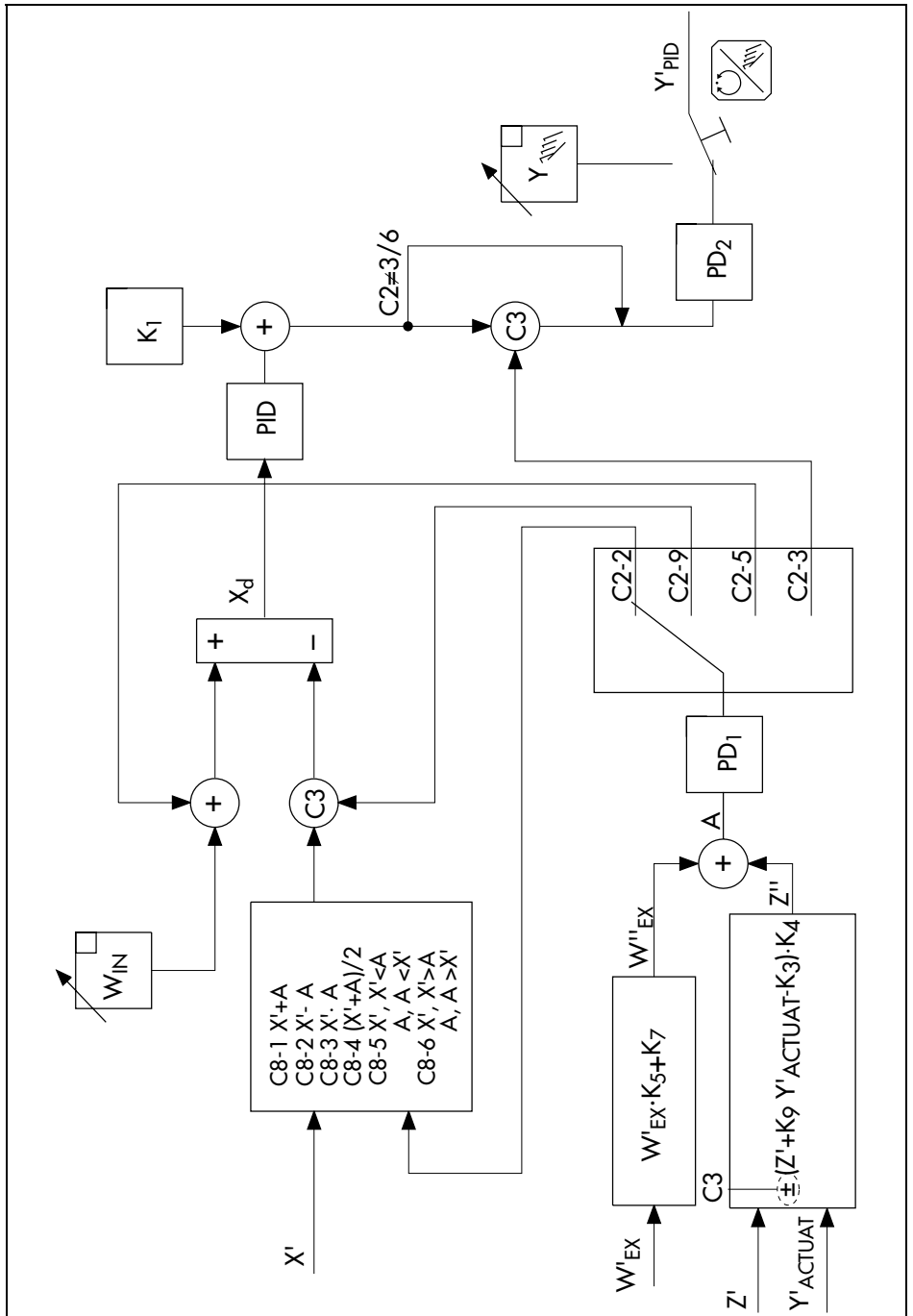

Fig. 31 · Feedforward control for fixed set point control - Example 1

Another variation of feedforward control for fixed set point control is shown in Fig. 32 . In this case, the input variables W''_{EX} and Z'' are not linked with each other.

C2-4 links W''_{EX} with the controlled variable X' .

C2-6 links W''_{EX} with the reference variable W_{IN} .

C2-4 and C2-6 link Z'' directly with the output of the process control station.

C3 determines the type of linking.

Parameters to be set, see section 4.1 and in addition:

K3	Decreases input signals Z' and Y'_{ACTUAT}
K4	Multiplication
K5	Multiplication by input variable W'_{EX}
K7	Addition to input variable W'_{EX}
K9	Multiplication by input variable Y'_{ACTUAT}
K ₁ X	Multiplication by X' (only for C8-7)
K ₁ Z	Multiplication by Z' (only for C8-7)
K ₁ W _{EX}	Multiplication by W'_{EX} (only for C8-7)
K _P K ₂	K _P value for PD ₁ element, see section 4.6.1
T _V K ₂	T _V value for PD ₁ element, see section 4.6.1

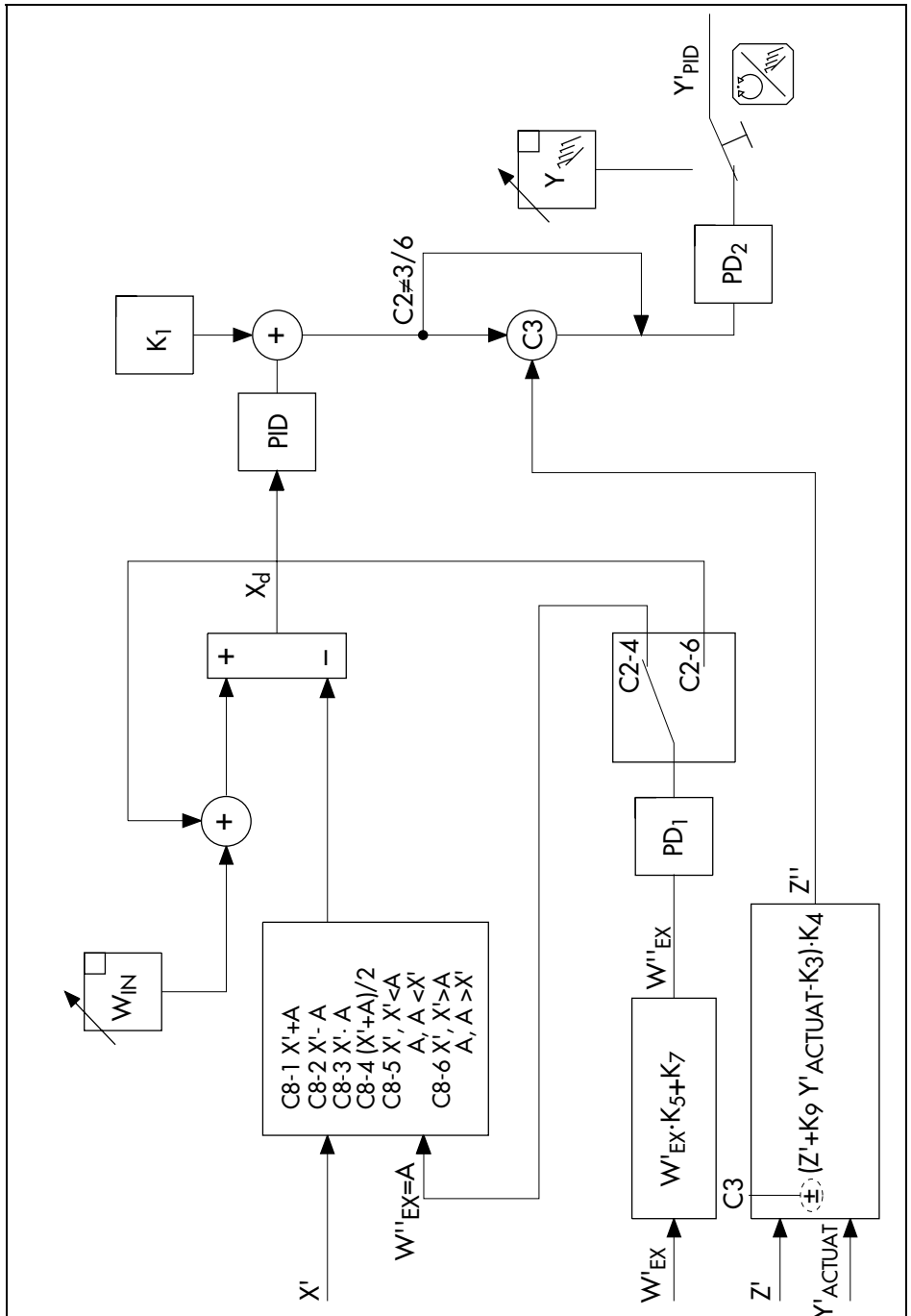

Fig. 32 · Feedforward control for fixed set point control - Example 2

A third option of how to connect feedforward control with fixed set point control is shown in Fig. 33 . For this purpose, activate the configuration switch **C8-7**. The input variables X' , W'_{EX} and Z' are linked with each other according to the calculation specification B. Depending on the setting of the configuration block C2, it is possible to include the signal A. This signal A results, in this case, from adding K_7 to the formula $\pm (K_9 \cdot Y'_{ACTUAT} - K_3) \cdot K_4$.

C2-9 links A with signal B. The type of linking is determined by C3.

C2-5 adds A to the internal reference variable.

C2-3 links A with the output of the process control station.

C2-6 adds K_7 to W_{IN} , and links the value $\pm (K_9 \cdot Y'_{ACTUAT} - K_3) \cdot K_4$ with the output of the PID controller.

The configuration switches C2-2 and C2-4 are inactive as long as C8-7 is set.

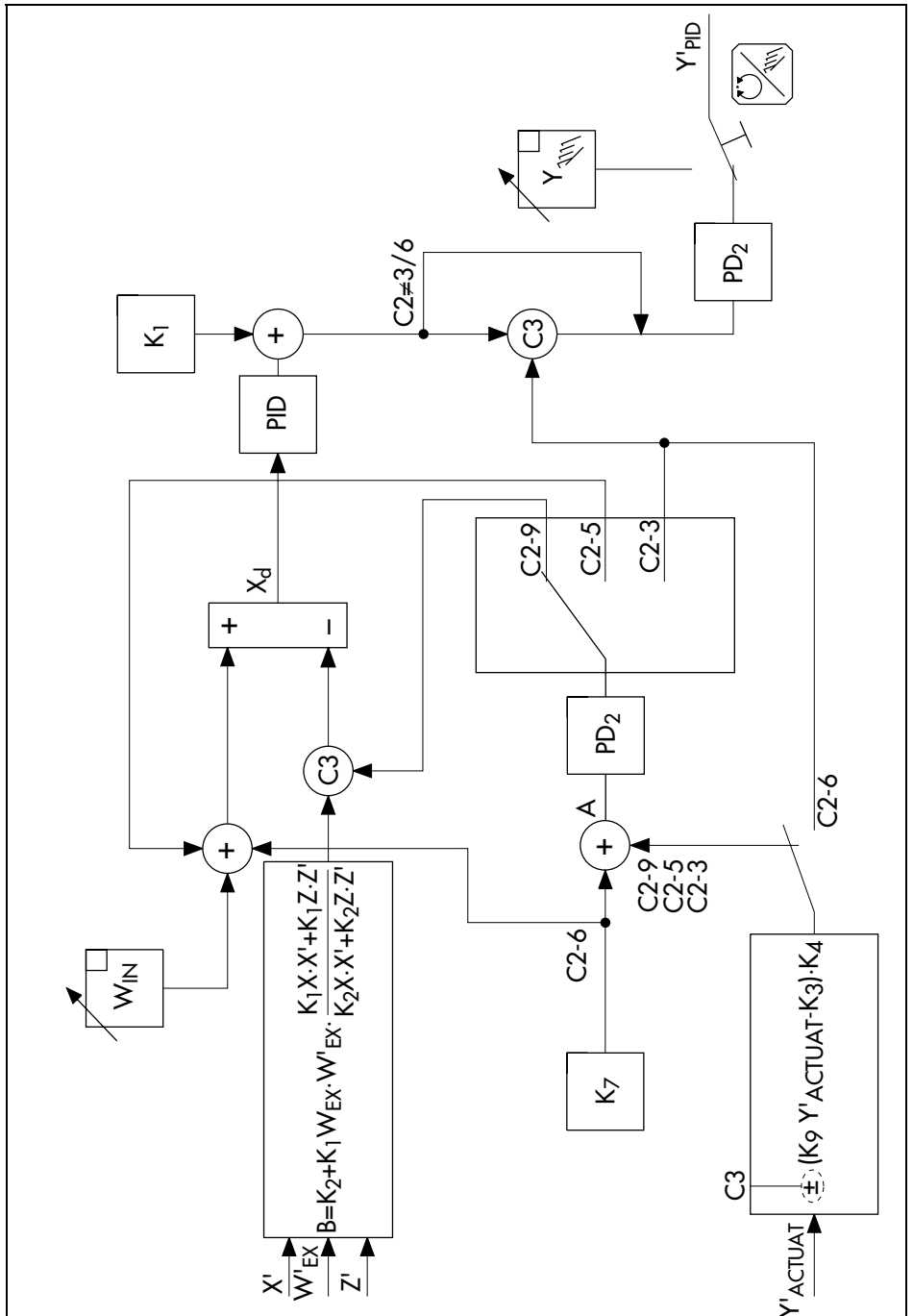

Fig. 33 · Feedforward control for fixed set point control - Example 3

4.6.3 Follow-up control with feedforward control

Follow-up control can be activated via configuration switch **C1-4** (FO1) or **C1-5** (FO2). The input variables Z' and Y'_{ACTUAT} must be used as disturbance variables. This is illustrated in Fig. 34. To begin, select the configuration blocks C2, C3 and C8.

The input variables Z' and Y'_{ACTUAT} are linked by the formula $\pm (Z' + K_9 \cdot Y'_{ACTUAT} - K_3) \cdot K_4$. The parameter K_9 multiplies the input variable Y'_{ACTUAT} by a certain factor. Z' and the multiplied input variable Y'_{ACTUAT} are then added up. The parameter K_3 decreases the resulting signal. Finally, the parameter K_4 multiplies the resulting signal by a certain factor. The mathematical sign for the formula mentioned above is determined by the configuration block C3, see corresponding paragraph in section 4.6, p. 49. (Note: For C3-1 to C3-8, the following applies to the contents in parentheses $(Z' + K_9 \cdot Y'_{ACTUAT} - K_3) \geq 0$). The newly generated signal is designated Z'' in the Figs.

In the configuration block **C2**, you can select either C2-2, C2-3, C2-5 or C2-9. Z'' and the parameter K_7 are added up to result in the signal A. This signal is linked with the controlled variable X' in the settings **C2-2** and **C2-9**.

C2-2 and C2-9 differ from each other as to the way of linking X' .

C2-2 is specified by the configuration switches C8-1 to C8-6.

C8-4 selects mean-value generation.

C8-5 selects the minimum output variable.

C8-6 selects the maximum output variable between X' and A.

C2-9 is defined by the configuration block C3.

C3-7, C3-8, C3-12 divide X' by A.

The following settings have the same results for both **C2-2** and **C2-9**:

C8-1, C3-1/2/9 add X to A.

C8-2, C3-3/4/10 subtract X from A.

C8-3, C3-5/6/11 multiply X by A.

C2-5 add the signal A to the active reference variable W_{IN} or W'_{EX} .

C2-3 links the signal A with the output of the process control station.

Parameters to be set, see section 4.2 and in addition:

K_3	Decreases input signal Z'
K_4	Multiplication
K_7	Addition to input variable Z''
K_9	Multiplication of input variable Y'_{ACTUAT}
$K_P K_2$	K_P value for PD_1 element, see section 4.6.1
$T_V K_2$	T_V value for PD_1 element, see section 4.6.1

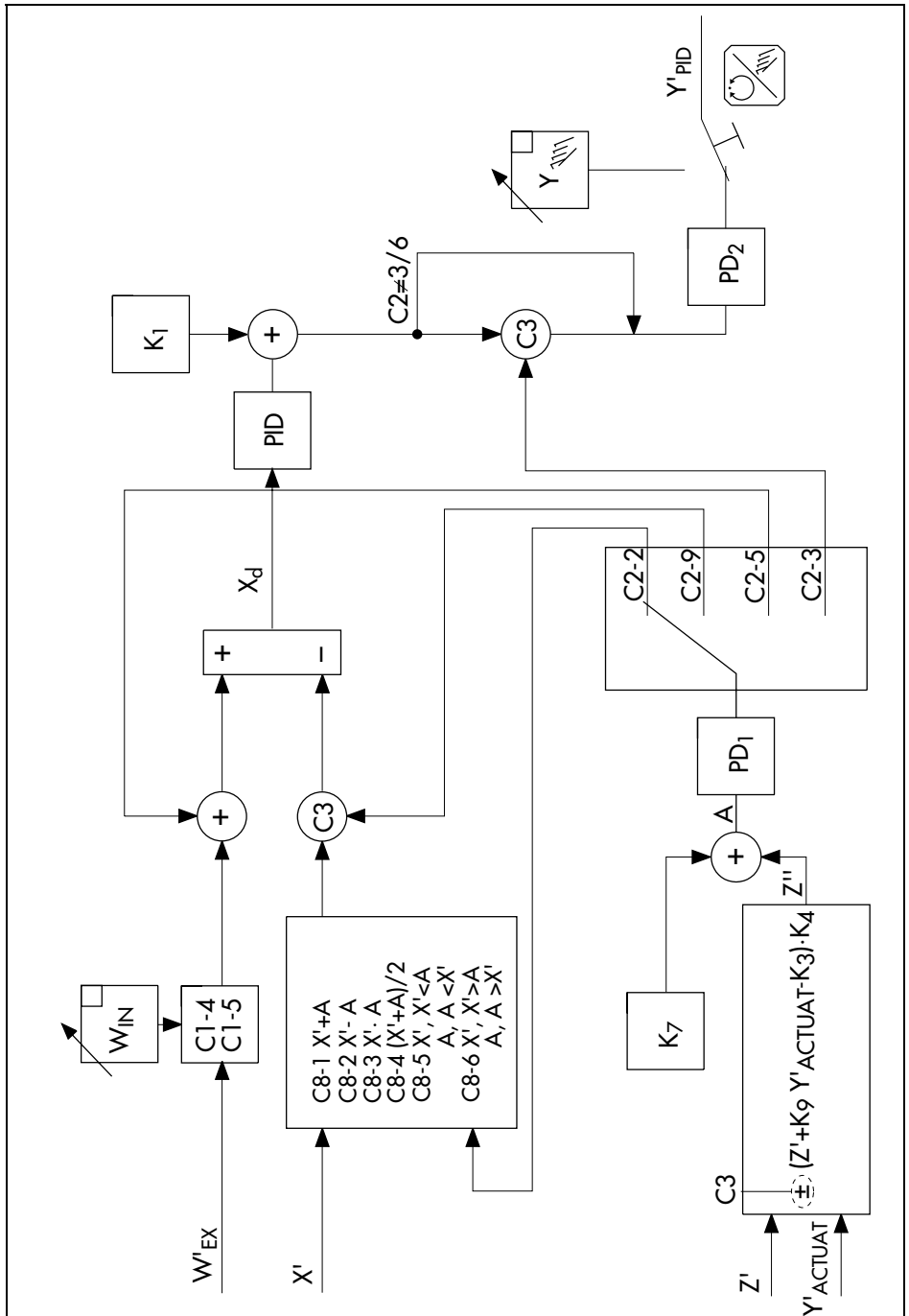

Fig. 34 · Feedforward control for follow-up control

4.6.4 Ratio control with feedforward control

Ratio control is selected via configuration switch **C1-7** or **C1-8**. Feedforward control included in ratio control with internal ratio (C1-7) is made possible by the input variables Z' and Y'_{ACTUAT} . Ratio control with internal/external ratio changeover can only be joined with feedforward control via input signal Y'_{ACTUAT} . Fig. 35 and Fig. 36 show the different options of feedforward control included in ratio control. For this purpose, adjust the configuration blocks C2, C3 and C8.

Ratio control with internal ratio (Fig. 35)

The input variables Z' and Y'_{ACTUAT} are linked by the formula $\pm (Z' + K_9 \cdot Y'_{ACTUAT} - K_3) \cdot K_4$. The parameter K_9 multiplies the input variable Y'_{ACTUAT} by a certain factor. Z' and the multiplied input variable Y'_{ACTUAT} are then added up. The parameter K_3 decreases the outgoing signal. At last, the parameter K_4 multiplies the outgoing signal by a certain factor. The mathematical sign for the formula mentioned above is determined by the configuration block C3, see corresponding paragraph in section 4.6, p. 49. (Note: For C3-1 to C3-8, the following applies to the contents in parentheses $(Z' + K_9 \cdot Y'_{ACTUAT} - K_3) \geq 0$). The newly generated signal is designated Z'' in the Figs.

In the configuration block **C2**, you can select the configuration switches C2-2, C2-3, C2-9 or C2-11. The disturbance variable Z'' and the parameter K_7 are added up to form the signal A. This signal is linked with the input variable X' in the settings **C2-2** and **C2-9**. The two configuration switches C2-2 and C2-9 partly differ from each other as to how they link X' .

C2-2 is specified by the configuration switches **C8-1** to **C8-6**.

C8-4 selects mean-value generation.

C8-5 selects the minimum output variable.

C8-6 selects the maximum output variable between X' and A.

C2-9 is specified by the configuration block C3.

C3-7, C3-8, C3-12 divides X' by A.

The following settings have the same results for both **C2-2** and **C2-9**:

C8-1, C3-1/2/9 add X to A

C8-2, C3-3/4/10 subtract X from A

C8-3, C3-5/6/11 multiply X by A.

C2-11 adds the signal A to the input variable W'_{EX} .

C2-3 links the signal A with the output of the process control station.

Parameters to be set, see section 4.3 and in addition:

K_3 Decreases input signal Z'

K_4 Multiplication of the decrease adjusted via K_3

K_7 Addition to input variable Z''

K_9 Multiplication of input variable Y'_{ACTUAT}

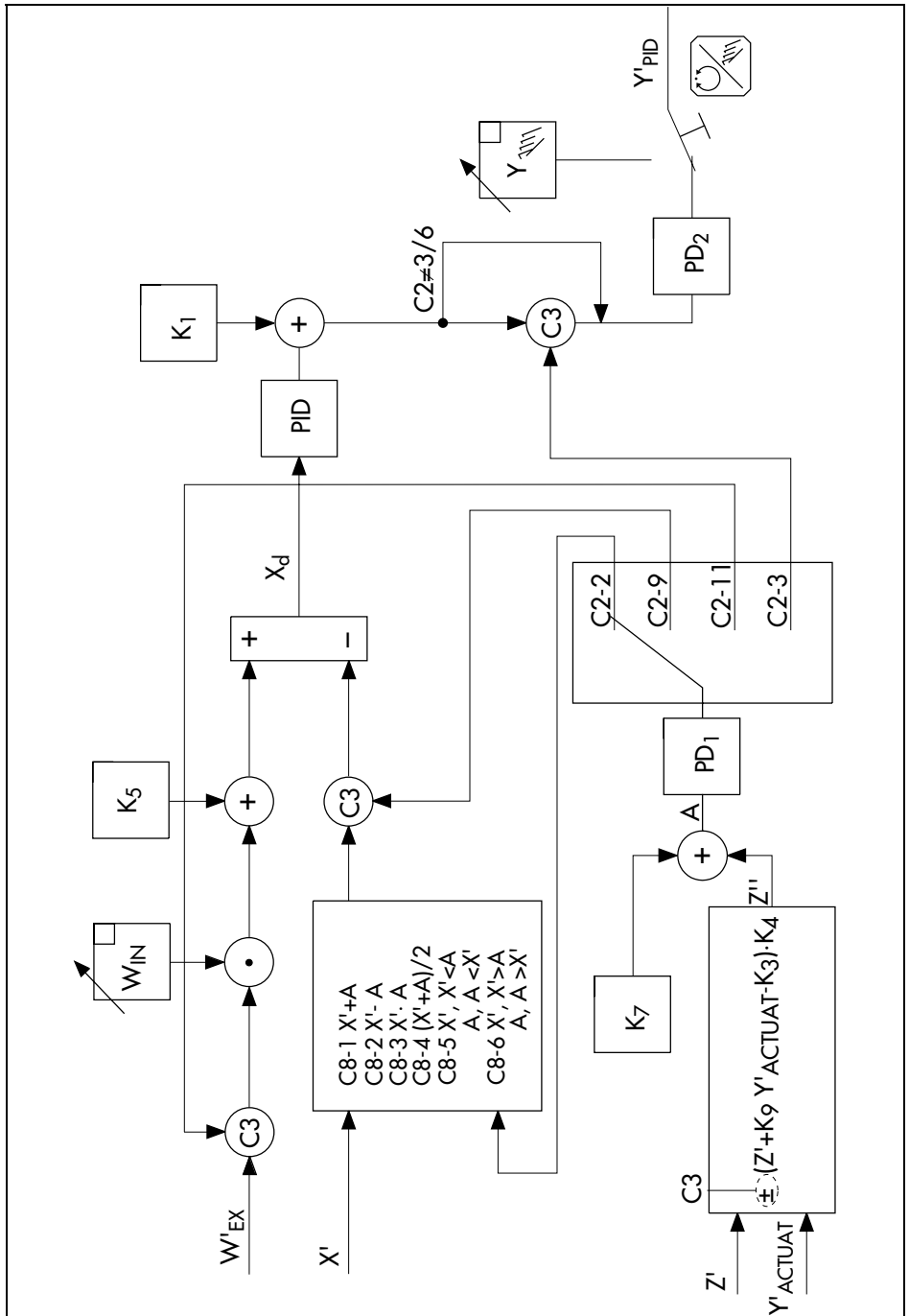

Fig. 35 · Feedforward control for ratio control with internal ratio

Ratio control with internal/external ratio changeover (Fig. 36)

Only the input variable Y_{ACTUAT} can be used as disturbance variable. The parameter K_9 multiplies Y_{ACTUAT} by a certain factor and K_3 decreases it. The resulting signal can be multiplied via K_4 . Finally, the resulting signal and the parameter K_7 are added up to form the signal A. Depending on which configuration switch has been selected in the configuration block C2,

C2-2 and C2-9 link the signal A with the input variable X' and

C2-3 links the signal A with the output of the process control station.

The difference between C2-2 and C2-9 is the same as for ratio control with internal ratio.

Parameters to be set, see section 4.3 and in addition:

K_3 Decreases input signal Z'

K_4 Multiplication of the decrease adjusted via K_3

K_7 Addition to input variable Z''

K_9 Multiplication of input variable Y_{ACTUAT}

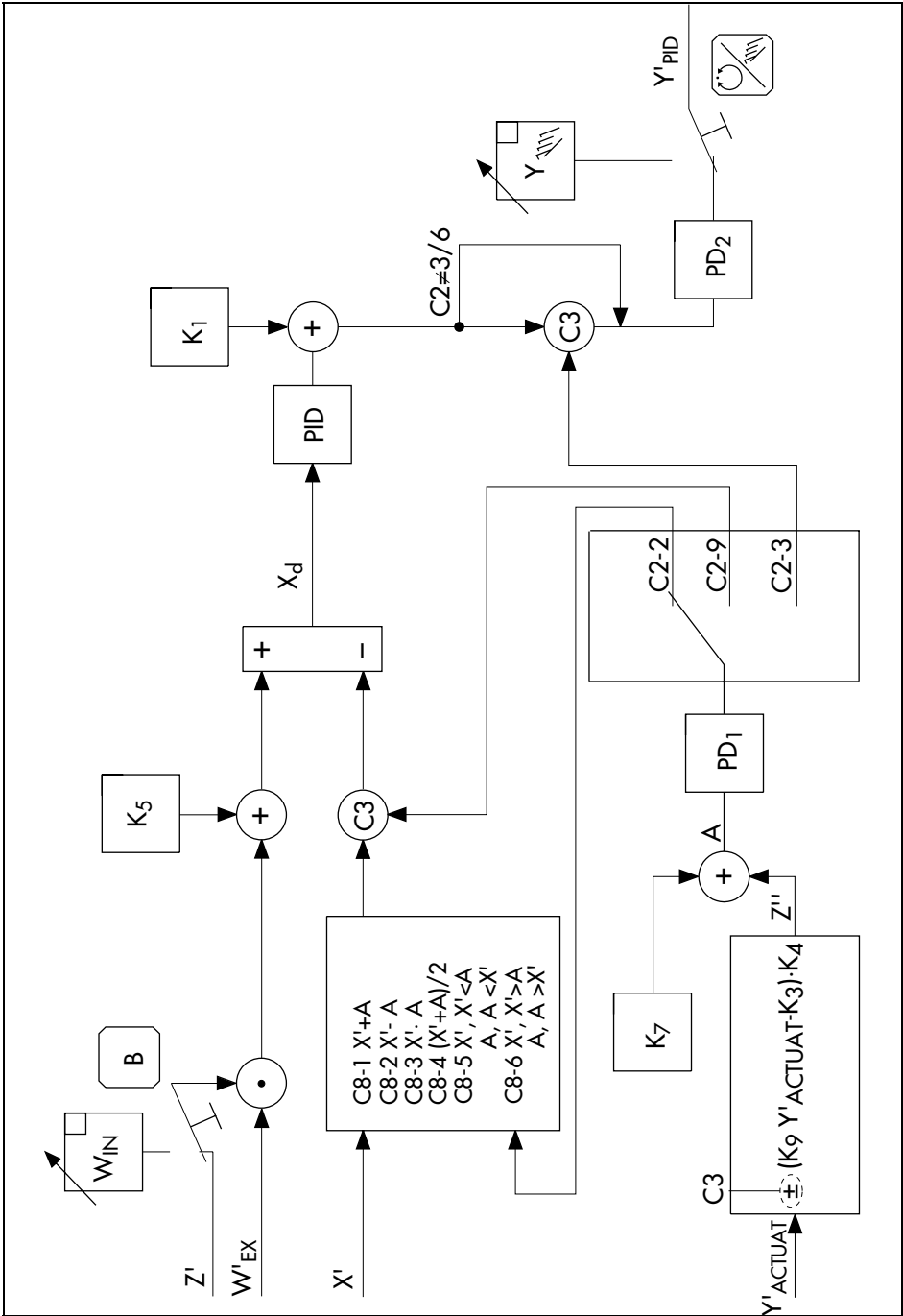

Fig. 36 · Feedforward control for ratio control with int./ext. ratio changeover

4.6.5 Cascade control modes with feedforward control

Cascade control is selected via configuration switch **C1-10** or **C1-11**. The input variable Y'_{ACTUAT} can be used for feedforward control. For cascade control with internal reference variable (C1-10), this may also be the input signal W'_{EX} . The Fig. 37 and Fig. 38 show the different possibilities of connection. For this purpose, adjust the configuration blocks C2, C3 and C8.

Cascade control with internal reference variable (Fig. 37)

The input variables Y'_{ACTUAT} and W'_{EX} can be used for feedforward control. They are both linked by the formula $K7 \pm (W'_{EX} + K9 \cdot Y'_{ACTUAT} - K3) \cdot K4$ to form the signal A. The parameters **K7**, **K9**, **K3** and **K4** are used to multiply as well as to increase or decrease the disturbance variables. **K9** multiplies the input signal Y'_{ACTUAT} by a certain factor. The parameter **K3** decreases the input variables W'_{EX} and Y'_{ACTUAT} which are added up. **K4** multiplies the outgoing signal. **K7**, finally, can add up or subtract, depending on the setting of the configuration block C3 (Note: For C3-1 to C3-8, the following applies to the contents in parentheses ($Z' + K9 \cdot Y'_{ACTUAT} - K3 \geq 0$)).

C2-2 and **C2-9** link the signal A with the input variable X' .

C2-5 links the signal A with the reference variable of the master controller.

C2-10 links the signal A with the output of the master controller.

C2-3 links the signal A with the output of the follower controller.

C2-7 links the signal A with the input variable Z' , i.e. with the controlled variable of the follower controller.

As mentioned in the introductory part of feedforward control (see p. 49), the configuration block **C3** is decisive for the type of signal linking at any point where C3 is included in the Figs. In this case, C3 is therefore decisive for C2-9, C2-10, C2-3 and C2-7.

For **C2-2**, the configuration block C8 is essential for linking the signal A with X' . This has also been described in the introductory part.

Parameters to be set: see the following

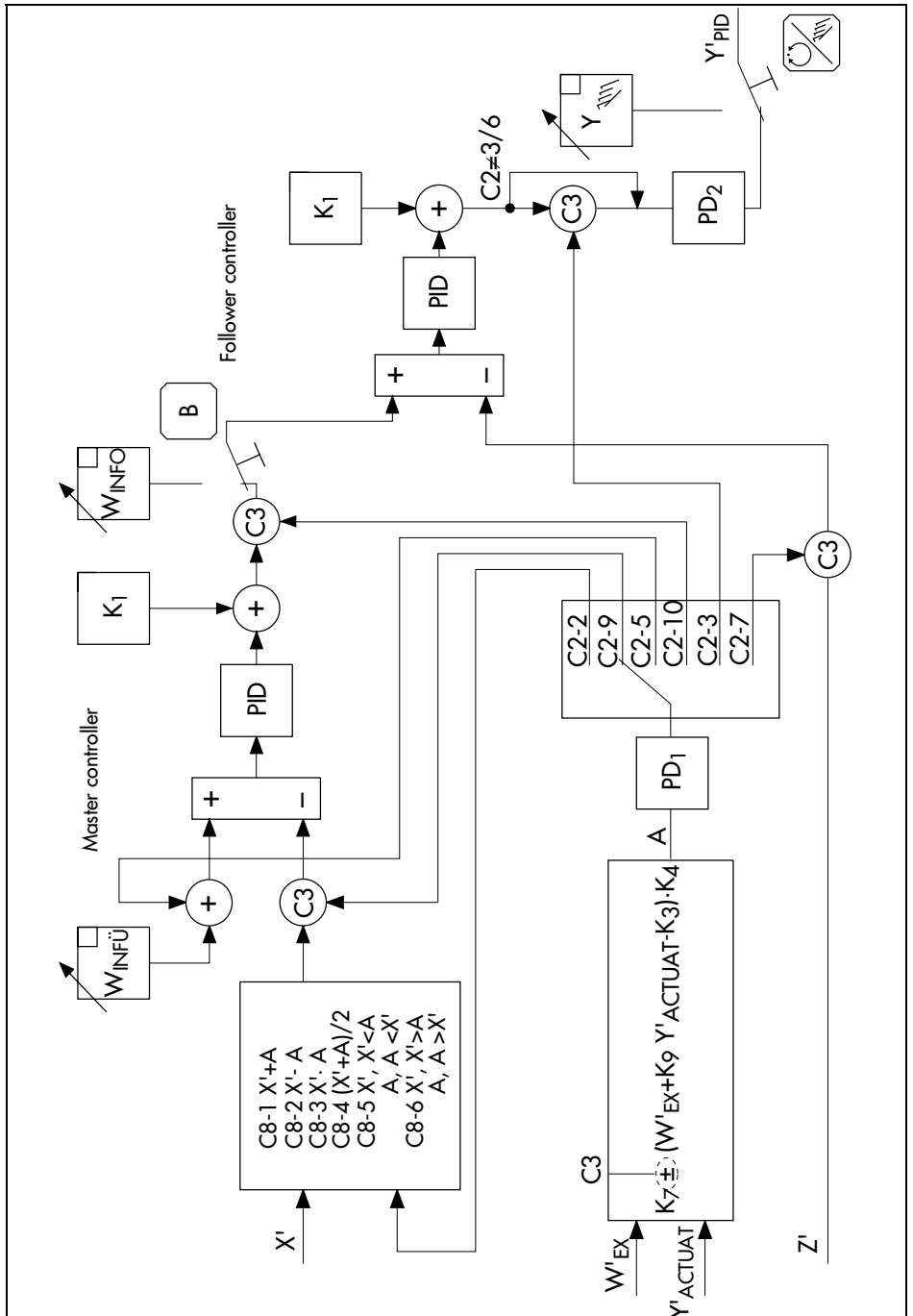

Fig. 37 · Feedforward control for cascade control with internal reference variable

Cascade control with external reference variable and feedforward control (Fig. 38)

The input variable Y'_{ACTUAT} is available for feedforward control. This input variable linked by the formula $K_7 \pm (K_9 \cdot Y'_{ACTUAT} - K_3) \cdot K_4$ results in the signal A. The parameters K_7 , K_9 , K_3 and K_4 are used to multiply as well as decrease or increase Y'_{ACTUAT} . K_9 multiplies Y'_{ACTUAT} . The parameter K_3 decreases Y'_{ACTUAT} . K_4 multiplies the resulting signal by a certain factor. K_7 , finally, can add up or subtract, depending on the setting of the configuration block C3 (Note: For C3-1 to C3-8, the following applies to the contents in parentheses ($Z' + K_9 \cdot Y'_{ACTUAT} - K_3$) ≥ 0).

C2-2 and **C2-9** links the signal A with the input variable X' .

C2-10 links the signal A with the output of the master controller.

C2-3 links the signal A with the output of the follower controller.

C2-7 links the signal A with the input variable Z' , i.e. with the controlled variable of the follower controller.

As mentioned in the introductory part of feedforward control (see p. 49), the configuration block **C3** is decisive for the type of signal linking at any point where C3 is included in the Figs. In this case, C3 is therefore decisive for C2-9, C2-10, C2-3 and C2-7.

For **C2-2**, the configuration block C8 is essential for linking the signal A with X' . This has also been described in the introductory part.

Parameters to be set, see section 4.4.1, p. 42, and in addition:

K_3	Decreases input signal Z'
K_4	Multiplication of the decrease adjusted via K_3
K_7	Addition to input variable Z'
K_9	Multiplication of input variable Y_{ACTUAT}
$K_P K_2$	K_P value for PD_1 element, see section 4.6.1
$T_V K_2$	T_V value for PD_1 element, see section 4.6.1

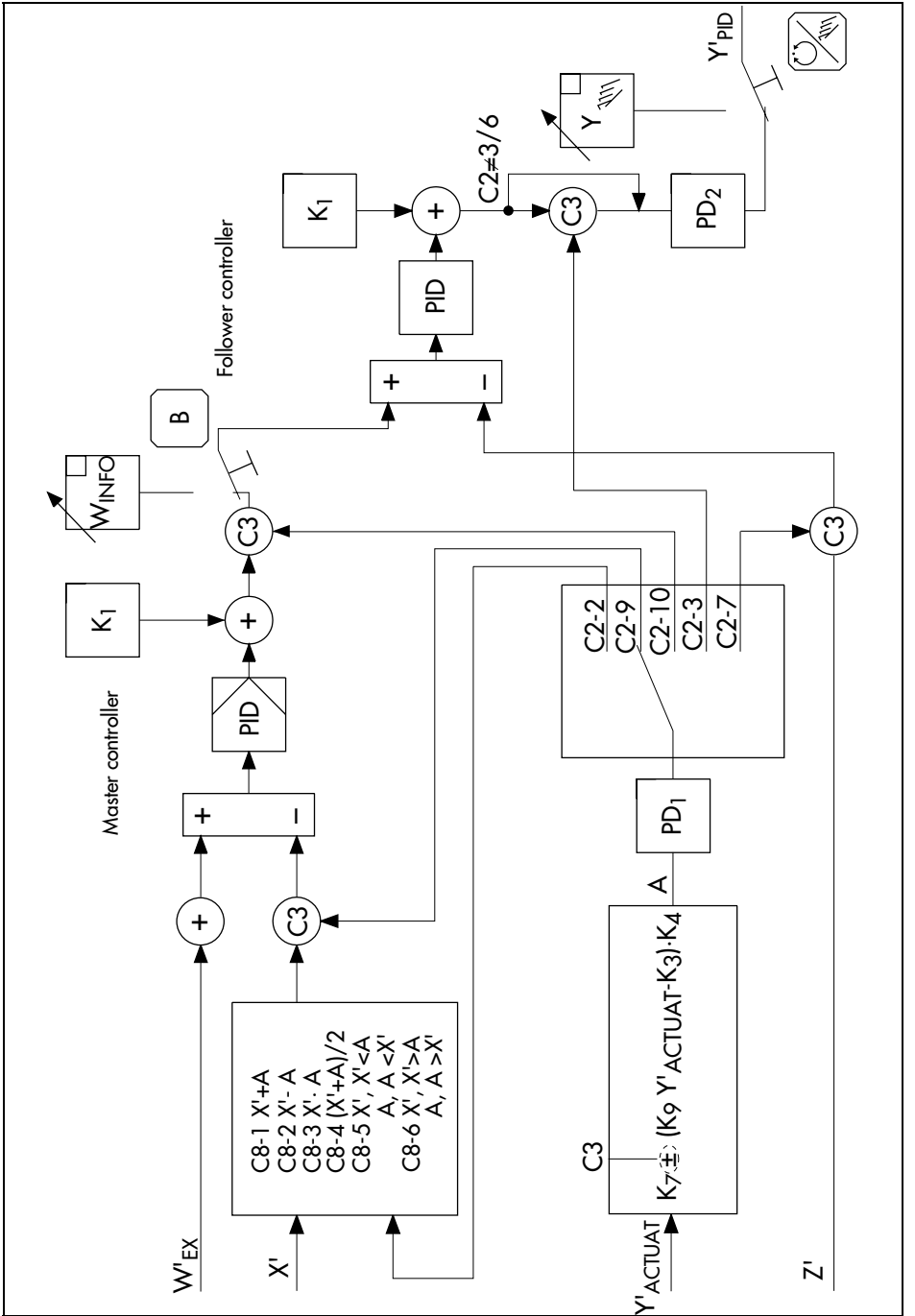

Fig. 38 · Feedforward control for cascade control with external reference variable

4.6.6 Limiting control with feedforward control

Limiting control with internal reference variable is selected via configuration switch **C1-10**, whereas limiting control with external reference variable is selected via **C1-11** and additionally via configuration switch $C33 \geq 8$. The input variable Y'_{ACTUAT} can be used for feedforward control. For feedforward control with internal reference variable (C1-10), this may also be W'_{EX} . The Fig. 39 and Fig. 40 illustrate the options with feedforward control.

Limiting control with internal reference variable (Fig. 39)

The input variables W'_{EX} and Y'_{ACTUAT} linked by the formula $K7 \pm (W'_{EX} + K9 \cdot Y'_{ACTUAT} - K3) \cdot K4$, result in the disturbance variable signal A. The parameters $K7$, $K9$, $K3$ and $K4$ are used to multiply as well as decrease or increase the disturbance variables. **K9** multiplies the input signal Y'_{ACTUAT} by a certain factor. **K3** decreases the input variables W'_{EX} and Y'_{ACTUAT} which have been added up. **K4** multiplies the resulting signal. **K7**, finally, can add up or subtract, depending on the setting of the configuration block C3 (Note: For C3-1 to C3-8, the following applies to the contents in parentheses $(Z' + K9 \cdot Y'_{ACTUAT} - K3) \geq 0$).

C2-2 and C2-9 link the signal A with the input variable X' of the limiting controller.

C2-5 links the signal A with the internal reference variable of the limiting controller.

C2-10 links the signal A with the output of the limiting controller.

C2-8 adds the signal A to the internal reference variable of the primary controller.

C2-3 links the signal A with the output of the primary controller.

C2-7 links the signal A with the input variable Z' (the controlled variable) of the primary controller.

As mentioned in the introductory part of feedforward control (see p. 49), the configuration block **C3** is decisive for the type of signal linking at any point where C3 is included in the Figs. In this case, C3 is therefore decisive for C2-9, C2-10, C2-3 and C2-7.

For **C2-2**, the configuration block C8 is essential for linking the signal A with X' . This has also been described in the introductory part.

Parameters to be set: see the following

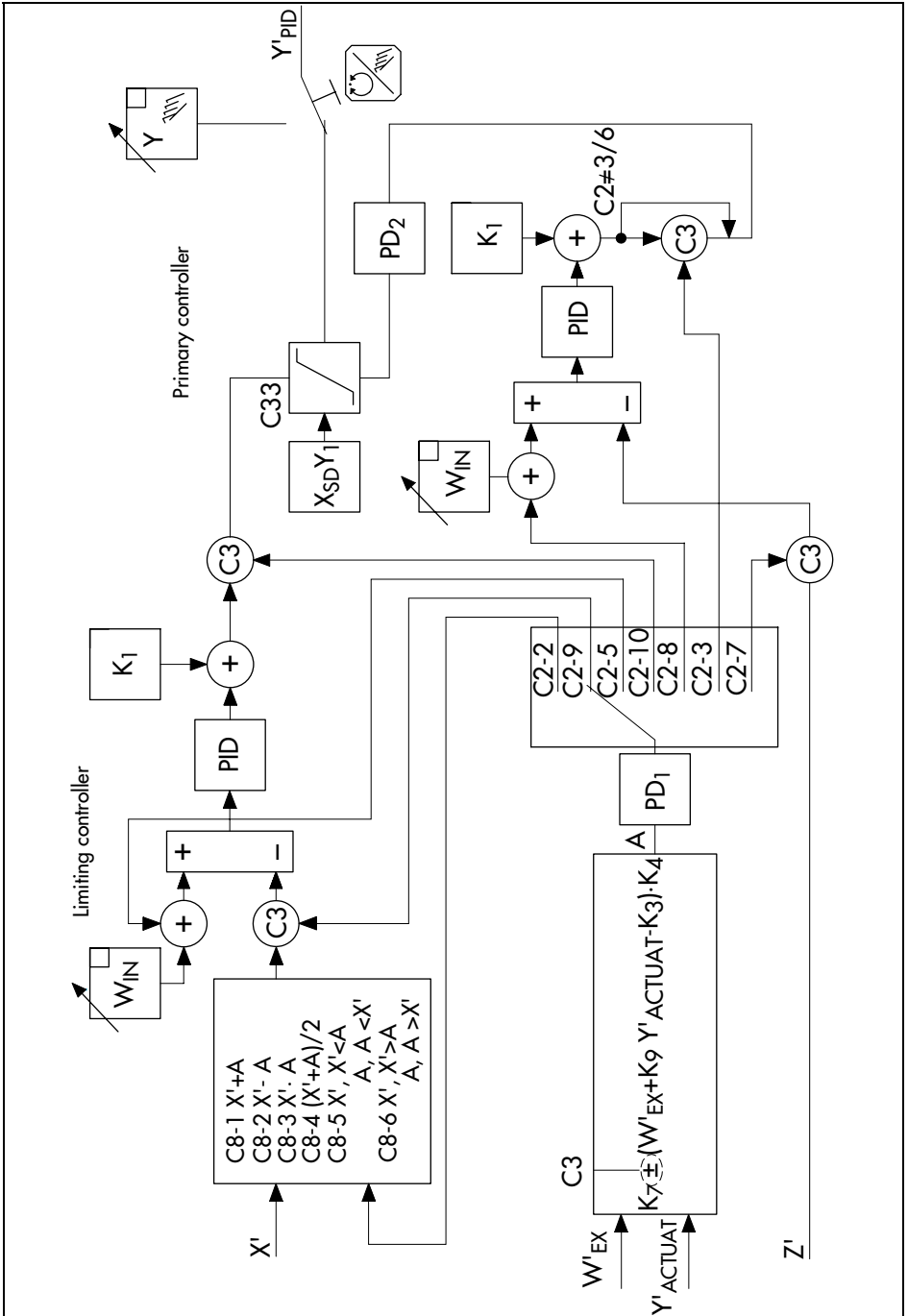

Fig. 39 · Feedforward control for limiting control with internal reference variable

Limiting control with external reference variable (Fig. 40)

In limiting control with external reference variable, only Y'_{ACTUAT} can be used as disturbance variable. The input variable Y'_{ACTUAT} is linked by the formula $K_7 \pm (K_9 \cdot Y'_{ACTUAT} - K_3) \cdot K_4$ and results in the signal A. The parameters apply in the same way as explained above. Only C2-5 is omitted in the configuration block C2. Apart from this, linking is possible in the same way as for limiting control with internal reference variable.

Parameters to be set, see section 4.4.3, S. 46 and in addition:

K_3	Decreases input signal Z'
K_4	Multiplication of the decrease adjusted via K_3
K_7	Addition to input variable Z''
K_9	Multiplication of input variable Y_{ACTUAT}
$K_P K_2$	K_P value for PD_1 element, see section 4.6.1
$T_V K_2$	T_V value for PD_1 element, see section 4.6.1

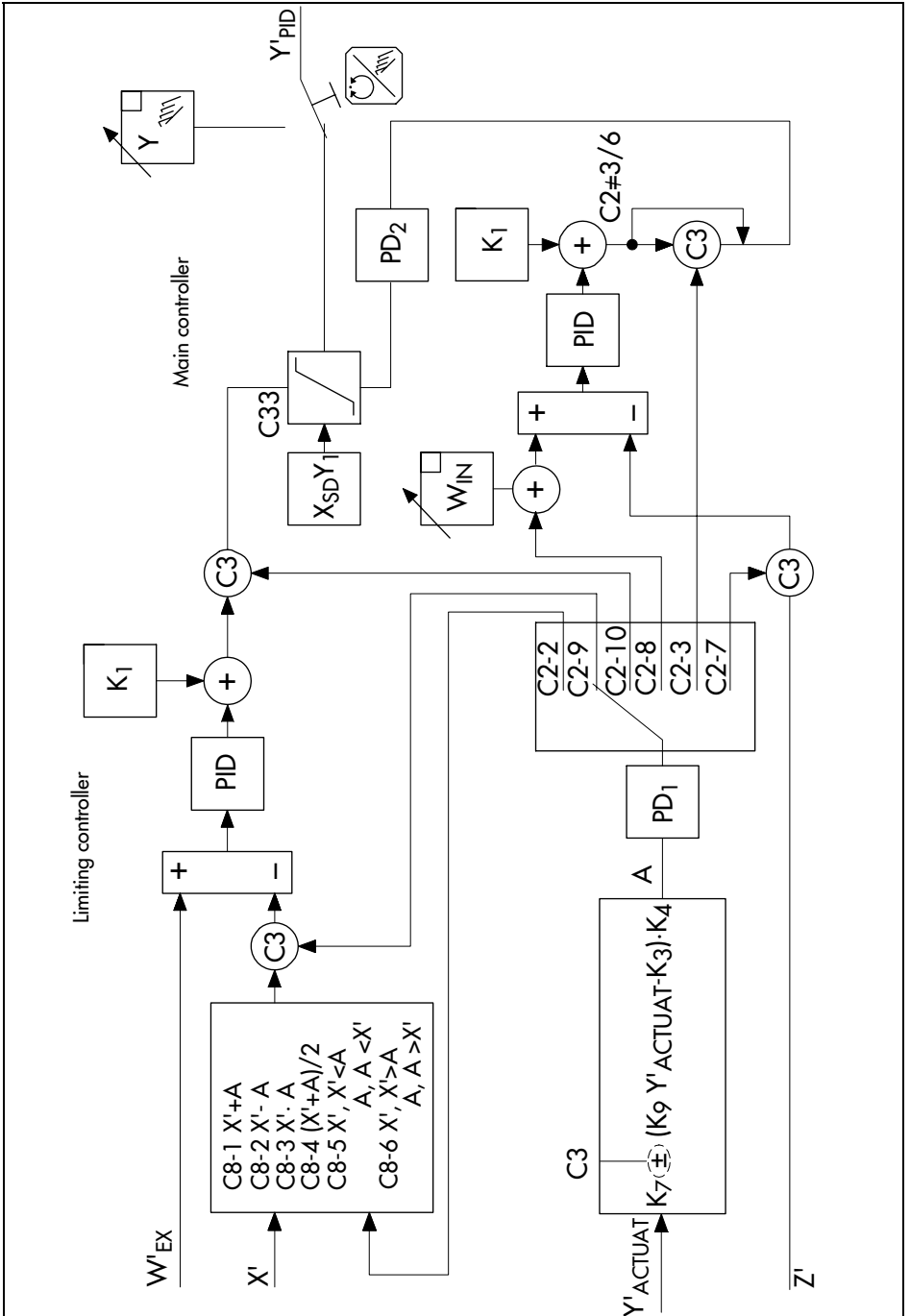

Fig. 40 · Feedforward control for limiting control with external reference variable

4.6.7 Synchro control with feedforward control

Synchro control is selected via configuration switch **C1-13**, as described in section 4.5. The input variables Y'_{ACTUAT} and Z' are available for feedforward control. How signals and variables are linked with each other is shown in Fig. 41 .

The input variables Z' and Y'_{ACTUAT} are linked by the formula $K_7 \pm (Z' + K_9 \cdot Y'_{ACTUAT} - K_3) \cdot K_4$. The parameter **K9** multiplies the input variable Y'_{ACTUAT} by a certain factor. Z' and the multiplied input variable Y'_{ACTUAT} are then added up. The parameter **K3** decreases the resulting signal. Finally, the parameter **K4** multiplies the resulting signal by a certain factor. The mathematical sign before the brackets is determined by the configuration block **C3**, see corresponding paragraph in section 4.6, p. 49 (Note: For C3-1 to C3-8, the following applies to the contents in parentheses $(Z' + K_9 \cdot Y'_{ACTUAT} - K_3) \geq 0$). In accordance with the mathematical sign, the parameter **K7** carries out addition or subtraction. The newly generated signal is designated A in the Fig.

C2-2 and C2-9 link the signal A with the controlled variable X' .

C2-3 links the signal A with the output of the process control station.

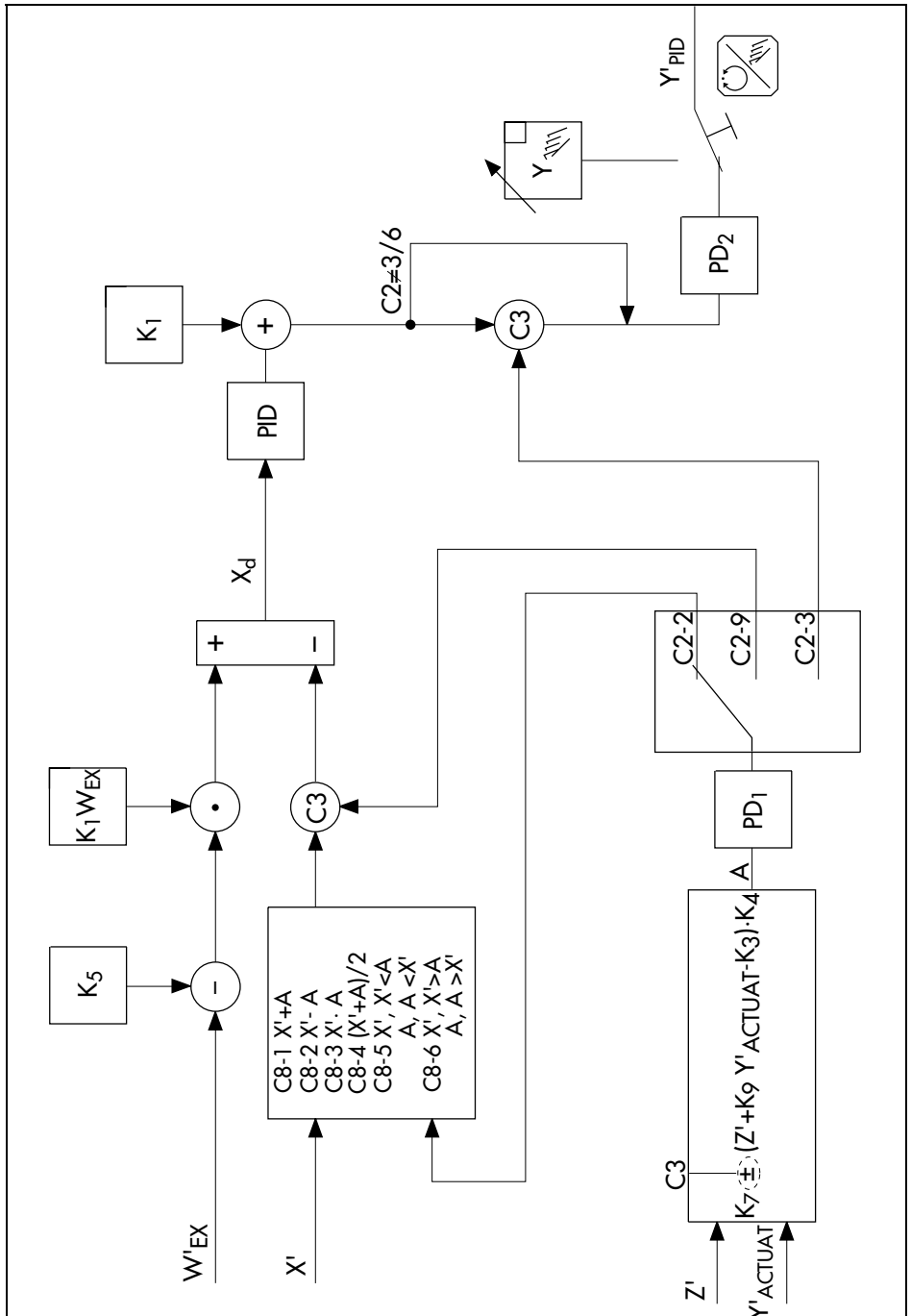

Fig. 41 · Feedforward control for synchro control

5 Output circuitry

5.1 Overview

The process control station basically comprises one continuous-action output, one discontinuous-action output and one binary output. As an option, the process control station can additionally be equipped with another controller output, an analog output, two limit relays and two binary outputs to extend its functionality. The subject of this section is how the individual outputs are configured with the help of C5 and which parameters need to be selected.

The minimum values of the signal pressure ranges for the continuous-action outputs and the analog output can be defined by the configuration block C31. Moreover, you will find details on how to adjust the operating direction via C6 and C32 and how to limit the output signals by means of the configuration blocks C33 to C36.

Under certain operating conditions, it is required to initialize defined output values. These safety output values are described in the final section.

The controller outputs Y₁ and Y₂ as well as the analog output Ao1 can be modified by function generation using C7-6 to -8. Function generation has been described in detail in section 3.8 so it will not be repeated here. It is possible to define an output ramp for the controller outputs Y₁ and Y₂. This function will be presented in section 6.2.

5.2 Configuration of controller outputs (C5)

The configuration block C5 defines the outputs of the process control station. As mentioned in the introductory part, the process control station can be set as to have one or two continuous-action outputs and one discontinuous-action output. For the discontinuous-action output, you have to configure either an on-off output or a three-step output. The on-off output can be without feedback or provided with a pulse-pause conversion. The three-step output can be configured as to have either internal or external position feedback but also external position feedback along with pulse-pause conversion. Both the on-off output as well as the three-step output operate on the Y₂ characteristic.

C5-2 sets up one continuous-action output Y₁.

C5-3 sets up two continuous-action outputs Y₁ and Y₂.

C5-4 to C5-8 activate the discontinuous-action output in addition to the two continuous-action outputs.

C5-9 to C5-13 do not select the continuous-action output Y₁, only the Y₂ output and the discontinuous-action output are made available. **In this setting in manual mode, the relay outputs are directly operated via key G, and for the three-step output, this is key H.**

The various outputs are described below.

5.2.1 Continuous-action controller outputs (C5-2 to -8)

Proceed as follows to configure the continuous-action outputs of the TROVIS 6412 Process Control Station:

C5-2 configures the continuous-action output Y_1 ,

C5-3 to C5-8 select two continuous-action outputs Y_1 and Y_2 and activate at the same time the split-range unit.

C5-9 to C5-13 make available the continuous-action output Y_2 only.

The table below lists which parameters must be set for the continuous-action outputs. To dampen the controlled system, TZX_d can be used to predetermine a minimum value for error from which the controller outputs will be modified.

Parameters to be set

TZX_d	Dead band, error	0.0 to 100.0 %
K_{PY_1} , K_{PY_2}	output signal amplification for outputs Y_1 , Y_2	see section 5.4.2
TZY_1 , TZY_2	Dead band point for outputs Y_1 , Y_2	see section 5.4.2
K_P , T_N , T_V	Control parameter depending on the dynamic behavior selected	see section 7.4

5.2.2 On-off output without feedback (C5-4/-9)

The on-off output without feedback is selected via configuration switches **C5-4** or **C5-9**. This kind of output can only assume two states, these are ON (1) or OFF (0).

For **C5-4**, the dead band point TZY_2 and the parameter $X_{SD}Y_2$ determine the point where the on-off output will be switched on or off, see Fig. 42. The parameter $X_{SD}Y_2$ represents the differential gap which serves to avoid that the on-off output constantly switches from ON to OFF upon small errors. You have to adjust the differential gap to a value between 0.1 and 100%. TZY_2 is a Y_{PID} percent value for the Y_2 output.

When selecting **C5-9**, the on-off output is activated whenever error is beyond a certain range which is determined by the differential gap $X_{SD}Y_2$ and which is about the current reference variable W . This range normally lies below the reference variable, see Fig. 43 on the left. If feedforward control is applied to the output via C2-2, the position of the differential gap can be modified by determining the parameter K_7 . In the example in Fig. 43 on the right, K_7 has been determined as follows: $K_7 = -\frac{1}{2} \cdot X_{SD}Y_2$. As a result, the position of the differential gap shifts symmetrically about the value of the reference variable W .

For **C5-9**, the operating direction must be set by C32-3.

Parameters to be set

TZX_d	Dead band, error	0.0 to 100.0 %
$X_{SD}Y_2$	Differential gap	0.1 to 100.0 % (0.2 to 2 %*)
TZY_2	Dead band point = Switching point (only C5-4)	0.1 to 100.0 %; see section 5.4.2

* Standard values

Note:

The limitations of the output variable Y_2 via configuration blocks C33, C35 and C36 as well as the function generation of Y_2 via C7-7 do not affect the on-off output.

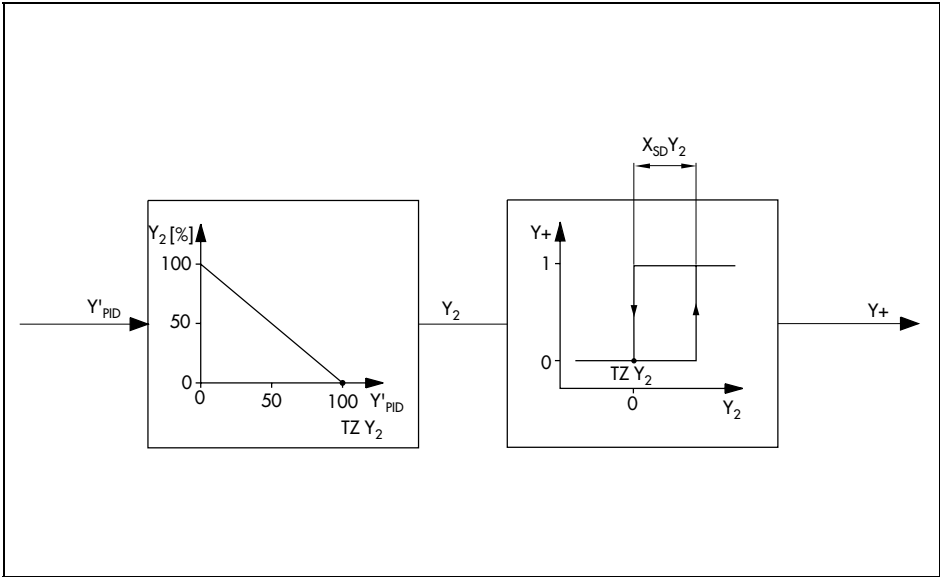

Fig. 42 · On-off output selected via C5-4

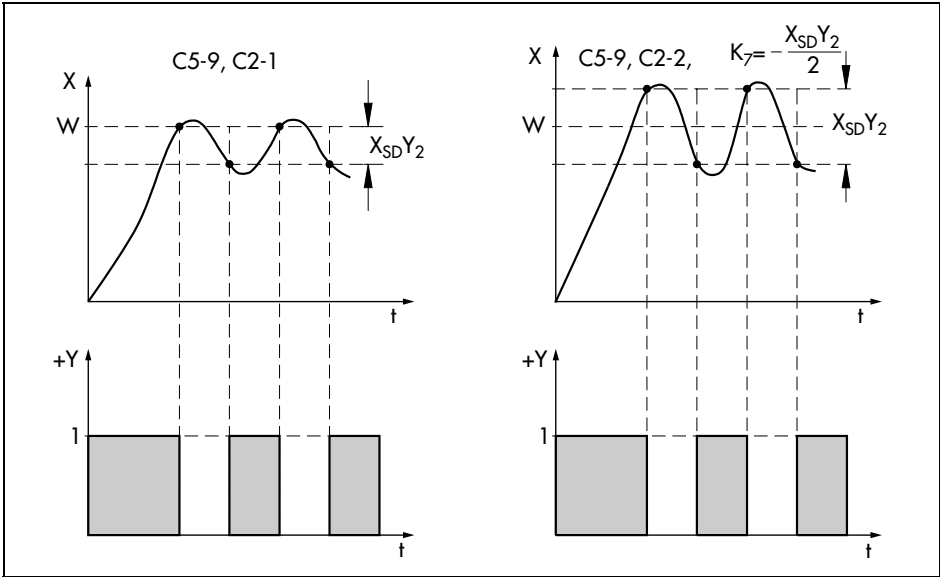

Fig. 43 · Differential gap of on-off output selected via C5-9

5.2.3 On-off output with pulse-pause converter (C5-5/-10)

The on-off output with pulse-pause converter is selected via configuration switch **C5-5** or **C5-10**. This output converts the continuous-action Y_2 signal into a pulse sequence. The duty cycle of the pulse sequence varies with regard to the Y_2 value, see Fig. 44 . The on-time T_E of the on-off signal Y_+ results from the following equation: $T_E = \frac{Y [\%]}{100 [\%]} \cdot T_{Y2} [s]$.

The parameter T_{Y2} represents the duty cycle as well as the maximum on-time. This parameter must be adjusted in the parameter level. Moreover, you have to define the parameter $T_{Y2\infty}$. The latter indicates the minimum on-time as percent value of the duty cycle. The minimum on-time in seconds $T_{E_{min}}$ calculates as follows:

$$T_{E_{min}} = \frac{T_{Y2} [s]}{100 \%} \cdot T_{Y2\infty} [\%]. \quad T_{E_{min}} \text{ is a hardware-related minimum of } 0.3 \text{ s.}$$

Carefully choosing the two parameters T_{Y2} and $T_{Y2\infty}$, will lead to an ideal compromise between low fluctuation of the controlled variable (high switching frequency) and long service life of the final control element (low switching frequency).

Parameters to be set

TZ_{Xd}	Dead band, error	0.0 to 100.0 %
T_{Y2}	Duty cycle	-1 to -1999 in minutes 0.1 to 1999 in seconds
$T_{Y2\infty}$	Minimum on-time	0.1 to 10.0 % of T_{Y2}

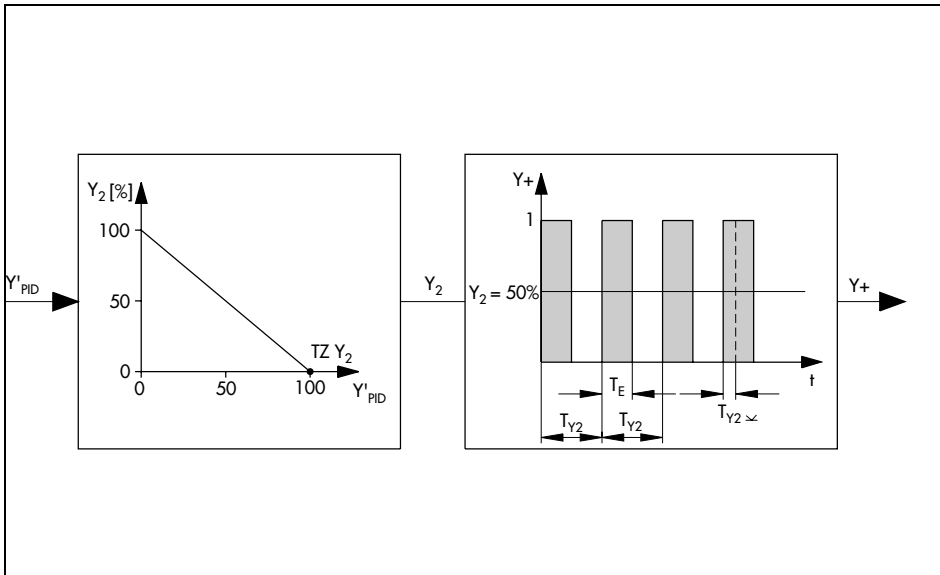

Fig. 44 · On-off output with PP converter

5.2.4 Three-step output with external position feedback (C5-6/-11)

The three-step output with external position feedback is selected via configuration switch **C5-6/-11**. The position of the connected actuator is fed back externally via Y_{ACTUAT} input, for example, using a potentiometer.

The output variable of the three-step output can assume three values: -100% , 0 and 100% . This controller output is, e.g., suitable for electric actuators. The three possible output variables could correspond to "Anti-clockwise rotation", "Motor OFF" or "Clockwise rotation". Between the two switching points is the dead band which can be defined as needed. This dead band is determined by the parameter TZ , see Fig. 45. Additionally, you have to define the parameter X_{SDY_2} which characterizes the differential gap. The differential gap applies to both switching points. Be sure the differential gap is always smaller than $\frac{TZ}{2}$.

A comparator is used to produce the difference between the Y_2 signal and the Y_{ACTUAT} signal. This difference constitutes the initial value of the three-step output. Where:

If the difference is larger than $\frac{TZ}{2}$ and greater than 0 , the Y_+ output will become active.

If it is larger than $\frac{TZ}{2}$ and smaller than 0 , the Y_- output will become active.

If the amount of this difference is smaller than $\frac{TZ}{2} - X_{SDY_2}$, the three-step output will be deactivated.

If a potentiometer is used for external position feedback, you have to adjust the potentiometer as described in the Mounting and operating instructions EB 6412 EN in the section "Ai level".

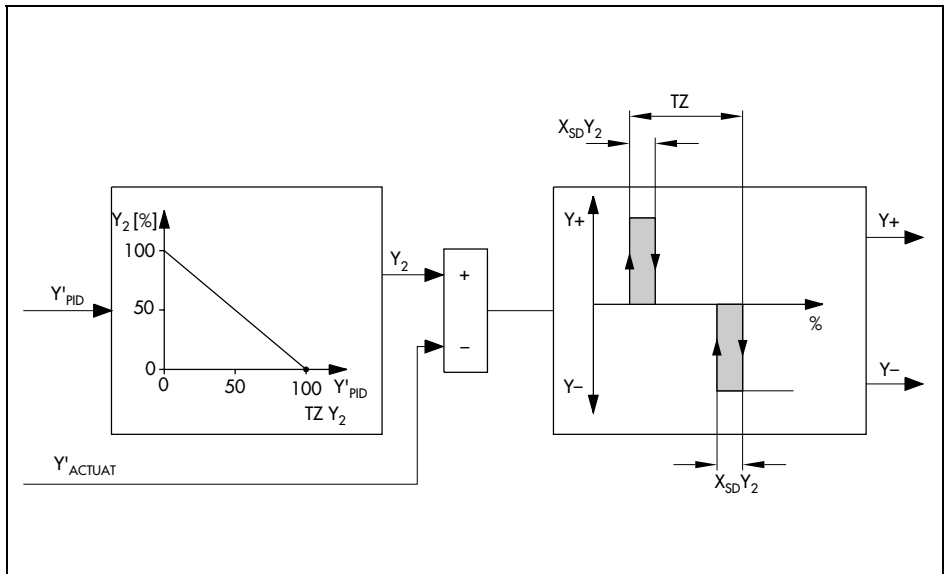

Fig. 45 · Three-step output with external position feedback

Parameters to be set

TZX _d	Dead band, error	0.0 to 100.0 %
TZ	Dead band	0.1 to 100.0 % (0.4 to 4 %*, TZ ≥ 2 · X _{SD} Y ₂)
X _{SD} Y ₂	Differential gap	0.1 to 100.0 % (0.2 to 2 %*)

* Standard values

5.2.5 Three-step output with internal position feedback (C5-7/-12)

The configuration switches **C5-7** and **C5-12** activate the three-step output with internal position feedback. The internal position feedback Y_R determines the position of the control valve by analyzing the speed of response of the connected actuator. This speed of response must be defined via parameter T_{Y2} .

Apart from this, both types of three-step outputs, with internal and with external position feedback, are equal. Additionally, the three-step output with internal position feedback can be adjusted as to have a minimum as well as a maximum Y_{PID} percent value at which the controller output is to issue a permanent signal. These minimum and maximum values are defined by the parameters $Y_2K_3\preceq$ and $Y_2K_3\preceq$.

Parameters to be set

TZX_d	Dead band, error	0.0 to 100.0 %
TZ	Dead band	0.1 to 100.0 % (0.4 to 4 %*, $TZ \geq 2 \cdot X_{SD}Y_2$)
$X_{SD}Y_2$	Differential gap	0.1 to 100.0 % (0.2 to 2 %*)
T_{Y2}	Actuator's speed of response	-1 to -1999 in minutes 0.1 to 1999 in seconds
$Y_2K_3\preceq$	Lower switching point, permanent signal	-10 to 110 %
$Y_2K_3\preceq$	Upper switching point, permanent signal	-10 to 110 %

* Standard values

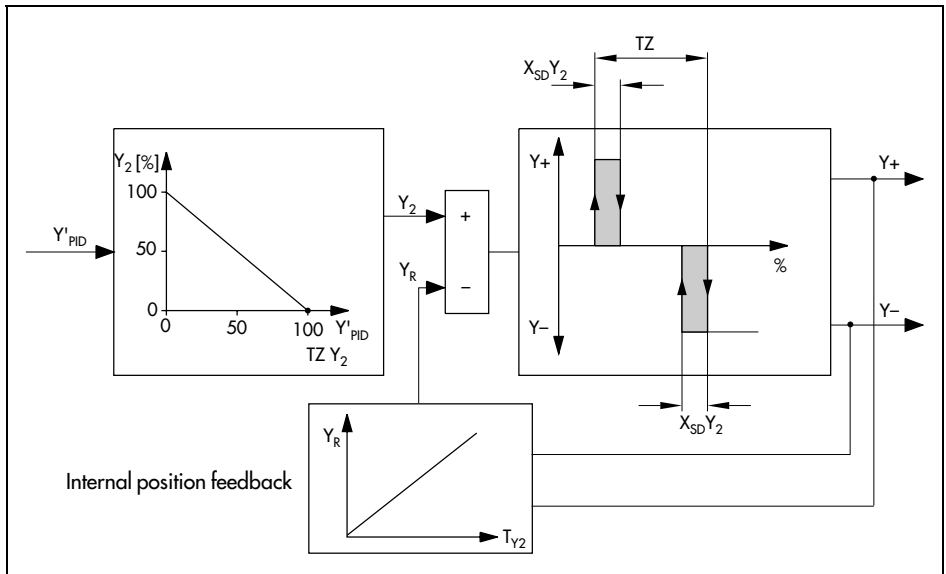

Fig. 46 · Three-step output with internal position feedback

5.2.6 Three-step output with external position feedback and pulse-pause converter (C5-8/-13)

The configuration switches C5-8 and C5-13 activate the three-step output with external position feedback and pulse-pause converter. In this setting, the three-step signal is converted into a pulse sequence. The characteristic of this output is illustrated in Fig. 47. The position of the connected final control element is fed back to the process control station via the Y_{ACTUAT} input. There, the difference between the Y₂ signal and the Y_{ACTUAT} signal is taken. The resulting signal is converted into a pulse sequence, depending on the adjusted duty cycle. The duty cycle can be determined for the Y₊ signal as well as for the Y₋ signal individually. The parameter T_{Y1} defines the duty cycle for the Y₋ signal, whereas the parameter T_{Y2} defines it for the Y₊ signal. Moreover, you have to define the minimum on-time of the duty cycle in percent via the parameters T_{Y1}∞ for the Y₋ signal and T_{Y2}∞ for the Y₊ signal. The minimum on-time in seconds calculates from this as follows:

$$T_{E_{\min}} = T_{Y1} \infty [\%] \cdot \frac{T_{Y1} [s]}{100\%} \text{ for } Y_{-} \text{ signal, or } T_{E_{\min}} = T_{Y2} \infty [\%] \cdot \frac{T_{Y2} [s]}{100\%} \text{ for } Y_{+} \text{ signal.}$$

Additionally, you have to determine the dead band for this output via parameter **TZ**. The dead band is given in percent with regard to the signal Y₂ - Y_{ACTUAT}. If needed, the parameters Y₂K₂ and Y₁K₂ which are amplifying factors can be modified. They and also the parameters T_{Y1} and T_{Y2} are used to adapt the connected actuator to different opening and closing times.

If a potentiometer is used for position feedback, you have to adjust the potentiometer as described in the Mounting and operating instructions EB 6412 EN in the section "Ai level".

Parameters to be set

TZX _d	Dead band, error	0.0 to 100.0 %
TZ	Dead band	0.1 to 100.0 % (0.4 to 5 %*)
T _{Y1}	Duty cycle for Y ₋	-1 to -1999 in minutes 0.1 to 1999 in seconds (10 to 30 s*)
T _{Y1} ∞	Minimum on-time	0.1 to 10.0 % of T _{Y1} (1 to 3 %*)
T _{Y2}	Duty cycle	-1 to -1999 in minutes 0.1 to 1999 in seconds (10 to 30 s*)
T _{Y2} ∞	Minimum on-time	0.1 to 10.0 % of T _{Y2} (1 to 3 %*)
Y ₁ K ₂ , Y ₂ K ₂	Amplification, threshold	0.0 to 100.0 (1 %*)

* Standard values

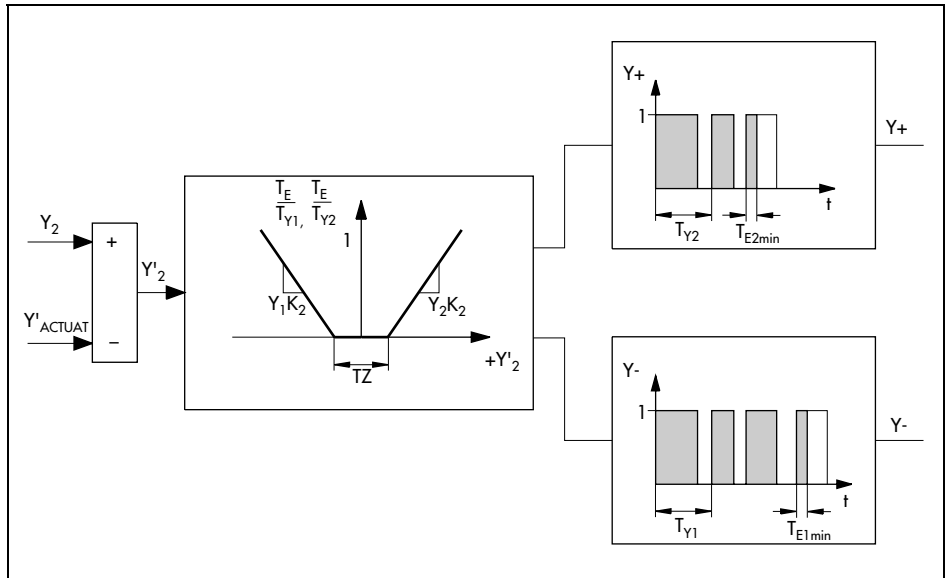

Fig. 47 · Three-step output with external position feedback and PP converter

5.3 Signal ranges (C31)

The configuration block C31 defines the minimum values of the output variable ranges of the Y₁ and Y₂ output as well as the signal range of the analog output Ao1, i.e. 0 or 4 mA or as well 0 or 2 V. The type of signal, this means mA signal or V signal, is determined by the soldering jumpers in the device. Please refer to the Mounting and operating instructions EB 6412 EN, section "Soldering jumpers on the logic board".

The minimum value of each signal can be determined separately. The relevant settings can be found in the configuration table in Appendix A. However, one particular fact must be pointed out:

If a device-related signal range of -10 to 10 V is predetermined for the analog output, select one of the configuration switches C31-1/-2/-3/-4.

5.4 Operating direction and split-range operation

The operating direction of the output signals is determined by the configuration block C6 "Inversion of error" on the one hand, and on the other hand by the configuration block C32. Split-range operation is activated as soon as one of the configuration switches C5-3 to C5-8 has been selected, and hence, two continuous-action outputs are configured.

5.4.1 Inversion of error (C6)

To invert the operating direction of the input, select the configuration block C6. Multiplication by -1 causes an increasing error to be converted into a decreasing error and, in return, a decreasing error to be converted into an increasing one. In doing this, the operating direction of the output signal is also inverted. Pay attention to the operating direction adjusted via configuration block C32, see section 5.4.2. This configuration block can change the operating direction once more.

Error can be inverted regardless of the control mode. In cascade control, it is possible to invert error of either the master controller or the follower controller or to change both simultaneously. Depending on the desired operating direction, the configuration switches have to be set as follows:

- C6-1** No inversion of error X_d , factory default
- C6-2** Inversion of error X_d , in cascade control, for both master and follower controller
- C6-3** Only for cascade control, inversion of error X_d for master or limiting controller
- C6-4** Only for cascade control, inversion of error X_d for follower or primary controller as well as for master or limiting controller

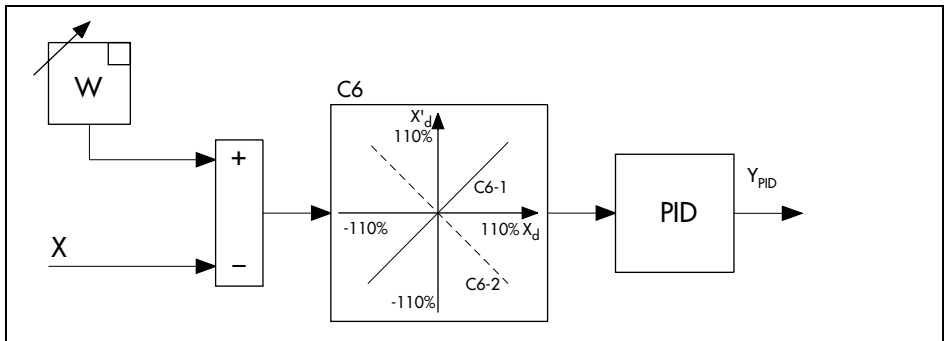

Fig. 48 · Inversion of error

5.4.2 Operating direction of output variables (C32) and split-range characteristics

The input variable(s) can act in the same direction or in the opposite direction of error. This operating direction is determined by the configuration block C32. The configuration switch C5-2 determines the operating direction of the output variable Y_1 . If two controller outputs have been set ($C5 \geq 3$), the operating direction of the output variables Y_1 and Y_2 will be defined. Note that the operating direction can also be inverted by the configuration block C6, see section 5.4.1.

Fig. 49 illustrates how the operating direction is fixed via configuration switches C32-1 to C32-4 for an increasing error.

C32-1 defines an increasing Y_1 variable and a decreasing Y_2 variable (Fig. 49 a)).

C32-2 defines both output variables as decreasing (Fig. 49 b)).

C32-3 defines both output variables as increasing (Fig. 49 c)).

C32-4 defines a decreasing Y_1 variable and an increasing Y_2 variable (Fig. 49 d)).

The split-range characteristics shown in Fig. 49 are described by two adjustable parameters. These are the dead band point (TZY_1 or TZY_2) and the output signal amplification (KpY_1 or KpY_2). They are included in Fig. 49. The dead band point defines the beginning of the characteristic. The second coordinate value of the initial point is fixed (Y_1 or Y_2 value) by definition of C32 and cannot be changed. The output signal amplification represents the increasing curve of the characteristic.

You can adjust any form of characteristic by changing the dead band points and/or the output signal amplifications. However, consider the following: the dead band points indicate a Y_{PID} percent value. They can be shifted along the Y_{PID} axis, beginning with the value defined by C32 (see Fig. 49). Upon this change, the value of the output signal amplification KpY_1 or KpY_2 is re-standardized.

Parameters to be set

KpY_1, KpY_2	Output signal amplification for Y_1, Y_2 outputs	0.1 to 10.0 %
TZY_1, TZY_2	Dead band point for Y_1, Y_2 outputs	0.1 to 100.0 %

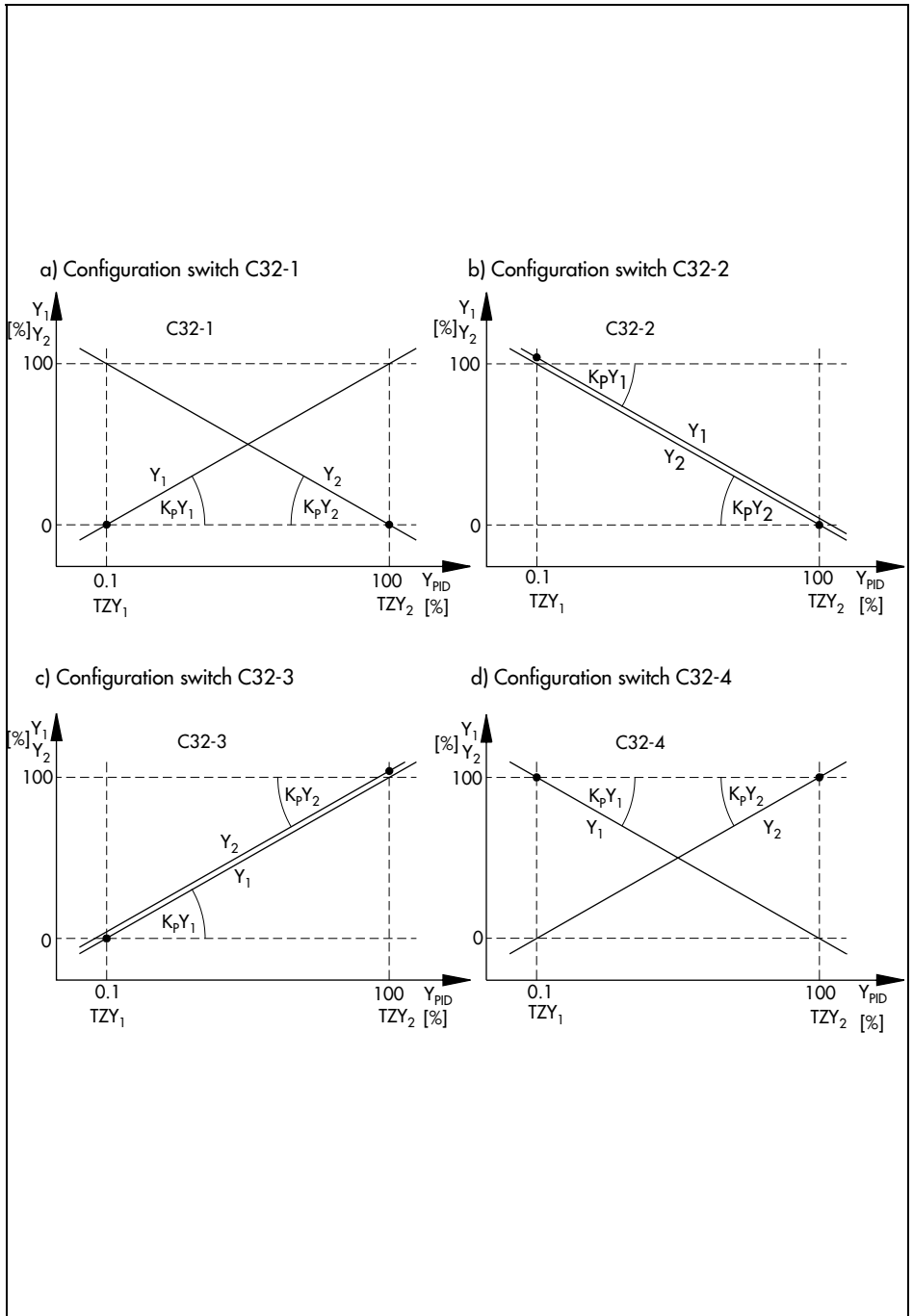

Fig. 49 · Different settings of the operating direction

In the following, two examples are presented to you, pointing out how to employ the two parameters dead band point and output signal amplification in order to adapt the characteristics of the output variables to the task to be performed:

Example 1 (see Fig. 50 a) and b)):

Two control valves with positioner are controlled by the continuous-action output Y_1 and the output Y_2 . The task consists of allowing the second control valve to open only when the first valve is already fully open. To do this, select the configuration switch C32-3, i.e. both output variables are increasing. Now, the two dead band points TZY_1 and TZY_2 are shifted to 50 %, respectively, in order to meet the requirements saying that control valve 2 is allowed to open only when control valve 1 is fully open.

Note: Even if in Fig. 50 b) the increasing curves of the characteristics have changed with regard to a), the values of the output signal amplification remain the same due to the internal standardization!

Example 2 (see Fig. 50 c) and d)):

Two control valves shall be controlled by the controller outputs, one valve for heating and the other one for cooling purposes. Therefore, we need a characteristic with a decreasing and an increasing curve. To do this, select the configuration switches C32-1 and C32-4. In this example C32-1 has been chosen, i.e. increasing Y_1 and decreasing Y_2 . Afterwards, the values of the output signal amplification KpY_1 and KpY_2 have been set to Two, respectively. As a result, the characteristics become steeper and the two output variables have a value of 100 % at an Y_{PID} of 50 %.

The same task, only with Y_1 and Y_2 the other way round, could have been performed by selecting C32-4 and shifting the dead band points to 50 %.

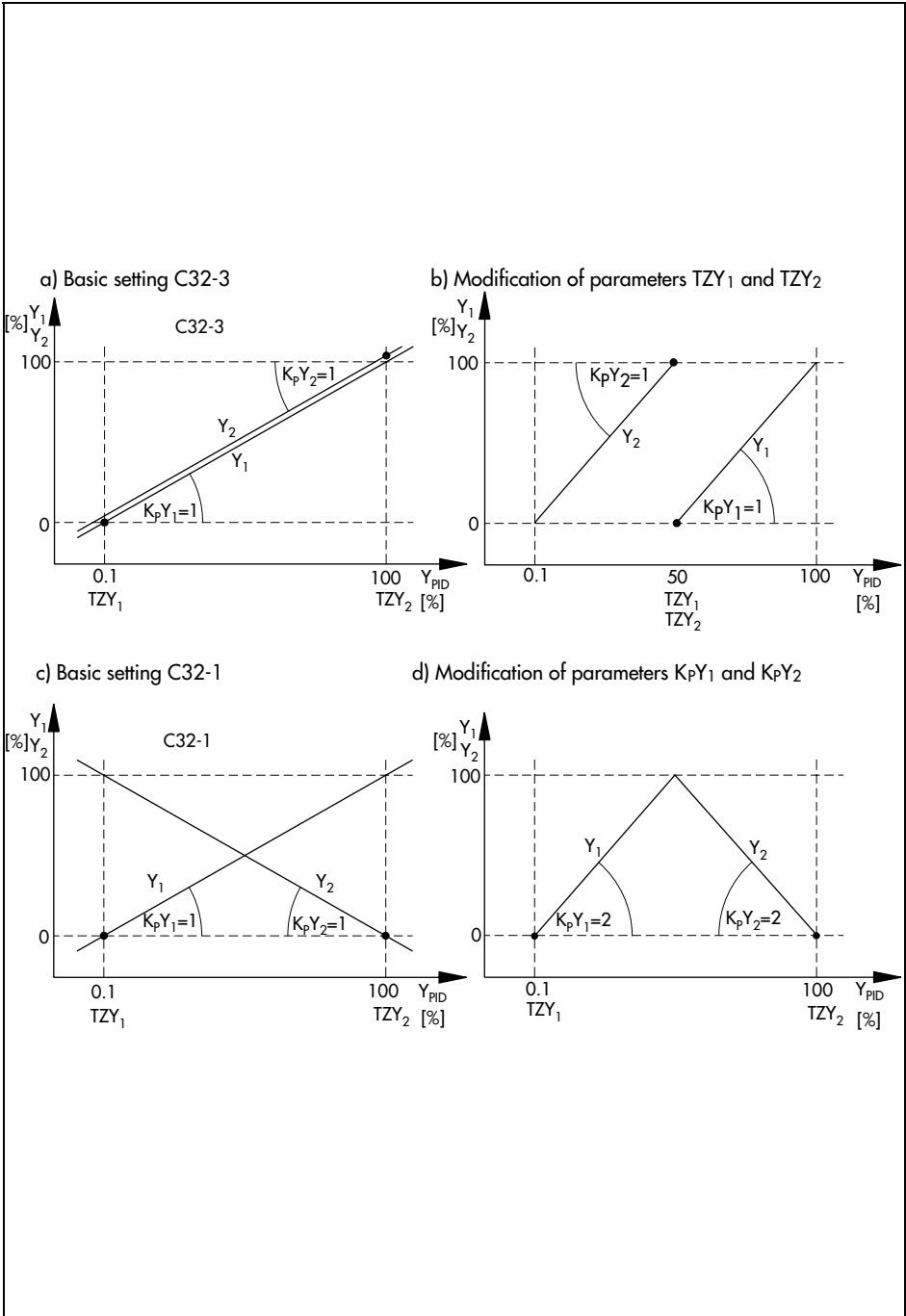

Fig. 50 · Examples for the setting of characteristics

5.5 Output signal limitation (C33, C35, C36)

The output variables Y_1 , Y_2 or Y_{PID} can be limited. For this purpose, the process control station offers different options, first, fixed limitation of a selected output variable by a minimum or maximum value via configuration block C35. Second, an output variable can be variably limited in one direction by the input variable Z via C33-2 to C33-7. The configuration block **C36** determines whether the limitations defined by C35 and C33 should also apply to manual mode or not: if so, set C36-1, if not so, then C36-2.

When selecting fixed limitation via configuration block **C35**, the output variable Y_1 is limited by C35-2, Y_2 by C35-3, Y_1 and Y_2 by C35-4 and, finally, Y_{PID} by C35-5. The maximum and minimum values for the output variables must be defined by the parameters Y_1^{\times} , Y_2^{\times} , Y_1^{\sphericalangle} , and/or Y_2^{\sphericalangle} . If Y_{PID} shall be limited, the parameters Y_1^{\times} and Y_1^{\sphericalangle} are decisive for limiting its range. Output signal limitation via configuration block C35 can be carried out for all control modes.

Variable limitation by the input signal Z via **C33** cannot be selected for ratio control RC2 and neither for the two cascade control modes CA1 and CA2. For all other control modes, you have the following possibilities:

- C33-2** Limitation of maximum value for Y_1
- C33-3** Limitation of minimum value for Y_1
- C33-4** Limitation of maximum value for Y_2
- C33-5** Limitation of minimum value for Y_2
- C33-6** Limitation of maximum value for Y_{PID}
- C33-7** Limitation of minimum value for Y_{PID}

The remaining configuration switches C33-8 to C33-15 can only be selected for cascade control. Upon selection of these configuration switches, cascade control is converted into limiting control, see section 4.4.3.

Note: Limitation via C35 has priority over limitation via C33.

Parameters to be set (only C35)

- | | |
|--|--|
| Y_1^{\times} or Y_2^{\times} | Maximum value for Y_1 (Y_{PID}) or Y_2 |
| Y_1^{\sphericalangle} or Y_2^{\sphericalangle} | Minimum value for Y_1 (Y_{PID}) or Y_2 |

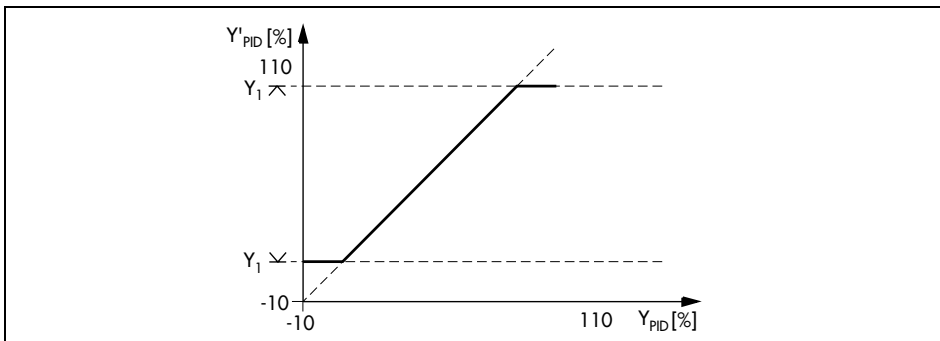

Fig. 51 · Limitation of Y_{PID} via C35-5

5.6 Limit relays

5.6.1 General definition

The TROVIS 6412 Process Control Station may optionally be equipped with two limit relays G1 and G2. They check a selected variable for exceeding or falling below a certain limit value. The limit relay assumes two switching states. If the switching condition is fulfilled, it is closed and if not, it is open.

The configuration blocks **C40** and **C41** determine which variable will be monitored by the limit relay and whether the limit relay shall be activated if the variable exceeds or falls below a certain limit value. The configuration block C40 is responsible for the limit relay G1, whereas C41 is responsible for G2. In cascade control mode, the limit relay G1 monitors the master controller and G2 the follower controller, see section 5.6.3. They differ from each other in their functionality also in ratio control. These differences will be described in section 5.6.4. Activation of the limit relays is indicated by "G1" or "G2" appearing on the display of the process control station.

The parameter **GW G1** is used to define the limit value of the selected variable for the limit relay G1. The parameter **GW G2** defines the limit value for G2. GW G1 and GW G2 are given in absolute values.

Moreover, you have to specify a differential gap (hysteresis) using the parameters **XSD G1** or **XSD G2**. This differential gap represents the period of time between switching on and switching off the limit relay.

Fig. 52 shows how the limit relays function and lists the parameters to be set.

Assuming that the limit relay checks a selected variable for exceeding the limit value, the limit relay is activated whenever the adjusted limit value GW G1 (or GW G2) is reached. In the reverse direction, the limit relay closes whenever the limit value GW G1 minus differential gap XSD G1 (or GW G2 minus XSD G2) has been achieved.

Assuming that the limit relay checks a selected variable for falling below the limit value, the limit relay is activated whenever the adjusted limit value GW G1 (or GW G2) is reached. In the reverse direction, the limit relay closes as soon as the limit value GW G1 plus differential gap XSD G1 (or GW G2 plus XSD G2) has been achieved.

When the limit relays are activated, the symbol ■ appears to the left of "G1" and "G2" on the display.

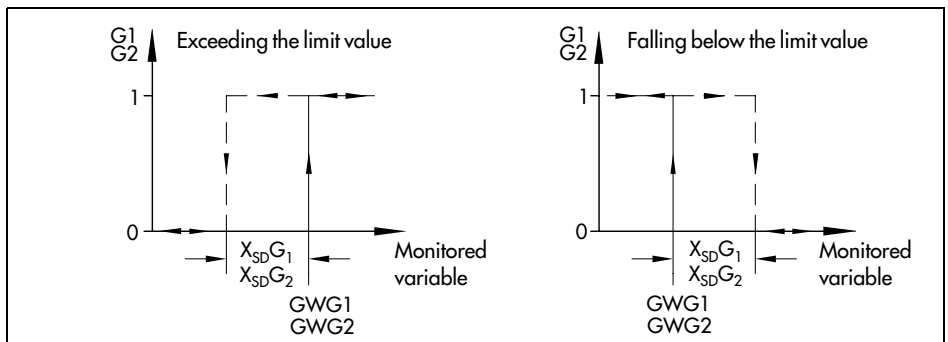

Fig. 52 · Functioning of limit relays G1 and G2

5.6.2 Assignment of limit relays (C40, C41)

As mentioned above, the configuration blocks C40 and C41 assign certain functions to the limit relays. Factory default is C40-1 and C41-1. In this setting, the limit relays are not assigned to any function.

The two limit relays have the same functions except for some special functions applying in cascade control and in ratio control mode. These particular functions will be described in the following sections 5.6.3 and 5.6.4. Here, we will have a closer look on the configuration block C40. This will also be representative for the configuration block C41.

The following variables can be checked for exceeding a certain limit value: the input variables X via **C40-2**, W_{EX} via **C40-3** and Z via **C40-4** as well as positive error X_d via **C40-5**. The amount of error can be checked via **C40-7**. Furthermore, the output variables Y_1 can be monitored via **C40-8**, Y_2 via **C40-9** and Y_{ACTUAT} via **C40-10**.

The following variables can be checked for falling below a certain limit value: the input variables X via **C40-11**, W_{EX} via **C40-12** and Z via **C40-13** as well as the output variables Y_1 via **C40-14**, Y_2 via **C40-15** and Y_{ACTUAT} via **C40-16**.

Parameters to be set

GW G1, GW G2	Limit values of the variable to be monitored, given in absolute values, for limit relay G1 or G2; Note: Values beyond the measuring range can be monitored!
X_{SD} G1, X_{SD} G2	Differential gap for G1 or G2 between 0.1 to 100.0 %

5.6.3 Limit relays for cascade control

In cascade control mode, the limit relay G1 is assigned to the master controller, whereas the limit relay G2 is responsible for the follower controller. Some of the configuration switches can therefore not be selected.

The input variables X and W_{EX} of the master controller can be monitored to check for exceeding or falling below a certain limit value. Hence, it is possible to configure C40-2 and C40-3 as well as C40-11 and C40-12. Positive error and the amount of error can additionally be monitored via C40-5 and C40-7, respectively.

For the follower controller, the configuration switches C41-2/-3/-11/-12 cannot be used. As for the rest of it, all the settings described in section 5.6.2 are available.

5.6.4 Limit relays for ratio control

For ratio control, the configuration switches C40-5 and C41-5 are different from those in section 5.6.2. If **C40-5** is set, G1 checks the actual value ratio for exceeding a certain limit value. In the setting **C41-5**, the differential ratio, this is the difference between actual value ratio and set point ratio, is monitored. Additionally, the configuration switch C40-6 can be selected in order to check the actual value ratio for falling below a certain limit value.

5.7 Binary outputs

The process control station includes one binary output (bo3) as standard and can optionally be equipped with two further binary outputs (bo1 and bo2). The binary outputs are able to indicate certain operating states. The configuration blocks C44 and C45 are used to determine the operating states to be indicated by the binary inputs bo1 and bo2, respectively. The messages from the binary output bo3 are not specified via software.

The status of the two binary outputs bo1 and bo2 can be inquired from the I-O level, see Mounting and operating instructions EB 6412 EN.

The binary outputs bo1 and bo2 are floating. The binary output bo3 is an electrically isolated transistor output.

5.7.1 Configuration of binary output bo1 (C44)

For the optional binary output bo1, the desired messages are defined via configuration block C44. For this purpose, the following settings are possible:

C44-1 Factory default, the binary output is left without any function.

C44-2 The binary output is active as long as the process control station is in the automatic mode. When switching to manual mode, the contact of the binary output is opened.

C44-3 The binary output opens whenever the values are beyond the measuring range, provided that the monitoring function has been activated via C15>1.

C44-4 The binary output opens if parameters or configuration blocks have changed without operator intervention. You will find an overview concerning these error messages in the appendix of the Mounting and operating instructions EB 6412 EN.

C44-5 The binary output opens if a reference value as adjusted in the configuration block C21 is activated upon failure of external system, error messages, etc.

C44-6 Only selectable for follow-up control with internal/external reference variable changeover and for ratio control with internal/external reference variable changeover. The binary output opens if the key (B) is adjusted to W_{IN} , which is the internal reference variable.

C44-7 The binary output can be activated by the RS 485 interface, provided it is available.

C44-8 The binary output issues a message in case the communication between the control station and the process control station or between the RS 485 interface and the process control station is interrupted

C44-9 Only selectable for cascade control. The binary output opens whenever the cascade is interrupted.

The status of the binary output bo1 is displayed in the I-O level in bo1.

5.7.2 Configuration of binary output bo2 (C45)

The functionality of the optional binary output bo2 equals that of the binary output bo1. The desired functions can be adjusted correspondingly via C45.

The status of the binary output bo2 is displayed in the I-O level in bo2.

5.7.3 Binary output bo3

The binary output bo3 cannot be freely defined by the user. It issues error messages which are produced by the process control station upon occurrence of various faults. These error messages and their possibly needed acknowledgement are listed in the appendix of the Mounting and operating instructions EB 6412 EN.

Whenever the binary output bo3 sends a signal, the red LED on the front panel of the process control station is on.

5.8 Assignment of the analog output (C48)

The process control station may contain an analog output Ao1, if requested. Different analog values are assigned to the analog output via configuration block C48. These analog values may be edited by means of a recorder. The following values may be assigned:

C48-1 is factory default and does not assign any values.

C48-2 assigns the X input to the analog output. Note that the input variable X can be modified by the configuration block C27 (Pt1 filter).

C48-3 assigns the W_{EX} input. Note that the input variable W_{EX} can be modified by the configuration block C27 (Pt1 filter).

C48-4 assigns the Z input. Note that the input variable Z can be modified by the configuration block C27 (Pt1 filter).

C48-5 applies the Y_{ACTUAT} value multiplied by the parameter K₈ to the analog output.

C48-6 assigns the reference variable or the ratio (set point ratio), when ratio control is selected, to the analog output.

C48-7 assigns the actual value of the controlled variable.

C48-8 is only available for ratio control. The actual value ratio is assigned to the analog output.

C48-9 is available for all control modes. Error is assigned to the analog output. For cascade control, error of the master controller or the limiting controller is transmitted to the analog output.

C48-10 to -12 are only available for cascade control, applying to the follower controller and the primary controller. The following variables of the follower and the primary controller are made available at the analog output: for **C48-10**, it is the reference variable, for **C48-11**, the actual value of the controlled variable, and for **C48-12**, it is error.

C48-13 is only available for cascade control. The output value of the master or limiting controller is assigned to the analog output.

C48-14 assigns the parameter Y_{1K5} to the analog output. This parameter is a constant the value of which can be determined as to be within a range of 0 to 100 %.

The analog output can be modified by function generation using configuration switch C7-8. This function has been described in detail in section 3.8.

5.9 Safety output values

The safety output values of the TROVIS 6412 Process Control Station are defined output values which are specified in the parameter level. They are activated under certain operating conditions in order to determine the position of the connected final control element.

Safety output variables are activated

- by external signals via binary inputs, see also section 3.9.5,
- when variables exceed or fall below a certain monitored measuring range, provided that C37-3 or C37-4 have been set, see section 3.5,
- upon power supply failure, depending on the conditions selected in the configuration block C43, see Mounting and operating instructions EB 6412 EN, section "Power supply failure".

The TROVIS 6412 Process Control Station includes four different safety output values: Y₁K₁, Y₂K₁, Y₁K₃ and Y₁K₄. They will be described in the following sections.

All safety output values must be defined in the parameter level within the range of –10 to 100 %. Factory default generally is –10 %.

5.9.1 Safety output value Y₁K₁

The safety output value Y₁K₁ is an output value which is issued to the controller output Y₁.

It can be initiated via binary input bi1 if **C17-5 or C17-6** is set. For details, please refer to section 3.9.5. When interrupting the safety mode by closing the binary input bi1, an output ramp, beginning with the safety output value, can be started. To do this, configure C34-3 or C34-4. Further details may be found in section 6.2.1.

The safety output value Y₁K₁ is also generated when variables exceed or fall below the measuring range, provided monitoring action is activated through **C15>1** together with the configuration switch C37-3. This function has been described in section 3.5.

Y₁K₁ is also issued to the controller output Y₁ upon power supply failure, provided **C43-1, C43-3, C43-5, C43-7, C43-9 or C43-11** has been set. The differences between the configuration switches mentioned are described in detail in the Mounting and operating instructions EB 6412 EN, section "Power supply failure".

5.9.2 Safety output value Y₂K₁

The safety output value Y₂K₁ is issued to the controller output Y₂.

It can be initiated via binary input bi2 if **C18-5 or C18-6** is set. For details, please refer to section 3.9.5. When interrupting the safety mode by closing the binary input bi2, an output ramp, beginning with the safety output value, can be started. To do this, configure C34-3 or C34-4. Further details may be found in section 6.2.1.

The safety output value Y₂K₁ is also generated at the controller output Y₂ when variables exceed or fall below the measuring range, provided monitoring action is activated through **C15>1** together with the configuration switch **C37-4**. This function has been described in section 3.5.

Y₂K₁ is also issued to the controller output Y₂ upon power supply failure, provided **C43-2, C43-4, C43-6, C43-8, C43-10 or C43-12** has been set. The differences between the configuration switches mentioned are described in detail in the Mounting and operating instructions EB 6412 EN, section "Power supply failure".

5.9.3 Safety output value Y_{1K3}

The safety output value Y_{1K3} is only initiated when the configuration switch **C17-5** together with **C18-5** have been selected and the binary inputs bi1 and bi2 are open at the same time. Now, the Y_{PID} output signal is set to the value of Y_{1K3} to form the basis for the continued control process as soon as the binary inputs close again, see also section 3.9.5.

5.9.4 Safety output value Y_{1K4}

The safety output value Y_{1K4} is initiated at the master controller output or the limiting controller output by the binary input bi3 only. However, the cascade control mode must have been activated and **C19-6** must additionally be selected. This function has already been introduced in section 3.9.5.

6 Ramp functions

6.1 Reference variable ramp (C16)

The configuration block C16 is used to define a reference variable ramp. The reference variable ramp represents the change in the reference variable at a constant rate. If the reference variable is changed, the process control station follows up to this change with delay in order to avoid the formation of oscillations in the control loop. The period of time the reference variable ramp is active is called run time and is determined by the parameter T_s . T_s refers to the entire defined measuring range, this means e.g. W_{IN} to W_{IN} or W_{EX} to W_{EX} . If the reference variable changes from one value W_1 to another value W_2 , the actual run time of the reference variable ramp is the time t_1 , as shown in Fig. 53.

The factory default is C16-1 and does not define a reference variable ramp.

Parameters to be set

T_s	Range:	-199	to	-1	in minutes
		1	to	1999	in seconds

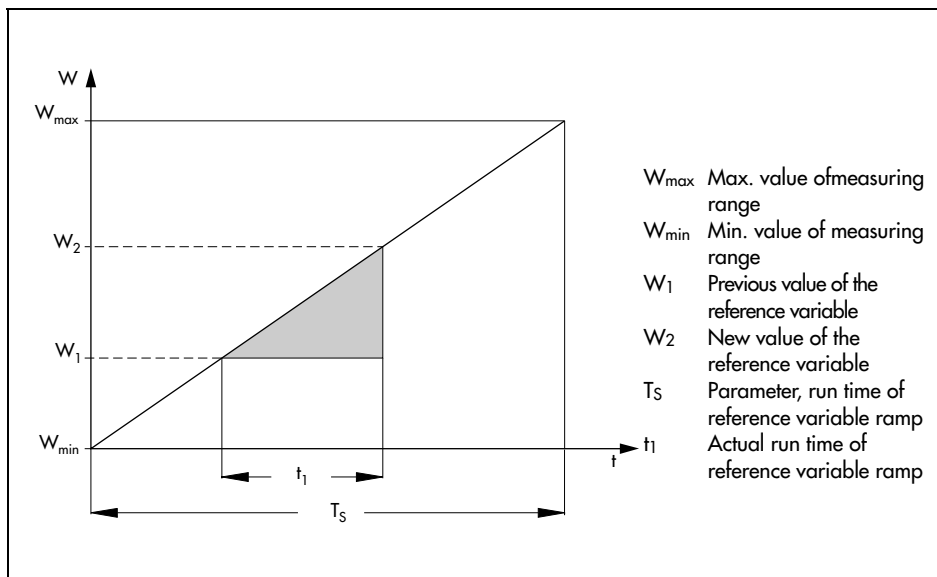

Fig. 53 · Reference variable ramp

6.1.1 Reference variable ramp with starting condition (C16-2, C17/18/19-3)

The configuration switch C16-2 is used to select a reference variable ramp which is started by a binary input. Therefore, C17-3, C18-3 or C19-3 are set to assign a binary input to this function. Upon activation of the binary input, the reference variable is set to the actual value of the controlled variable. After the binary input has closed, the reference variable assumes the preset value of the internal or external reference variable and is active corresponding to the run time T_S defined for the reference variable ramp. Finally, this reference variable is deactivated.

If manual mode is active or if this mode is going to be activated when the set point ramp is activated or already in action, the reference variable is set to the actual value of the controlled variable (X-tracking). The reference variable ramp will start with this value only if the system is returned to automatic mode.

If a reference value according to the configuration block C21 (reference variable upon failure of external system) becomes active during the reference variable ramp runs, the reference variable ramp is stopped. It starts again from this value on if this reference variable has been deactivated. This is done using a second binary input which can be selected via C17/18/19-2, see also section 3.9.1.

Parameters to be set

Same as for section 6.1

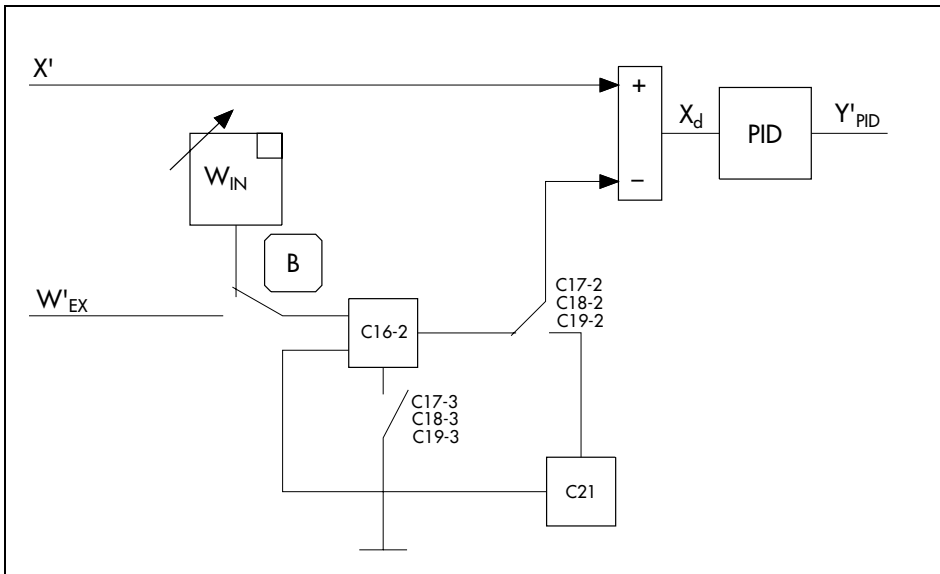

Fig. 54 · Reference variable ramp with starting condition via binary input

6.1.2 Reference variable ramp without starting condition (C16-3)

The configuration switch C16-3 is used to configure a reference variable ramp without starting condition. The latter is active in automatic mode whenever the reference variable is changed and also when switching between internal and external reference variable.

In manual mode, the reference variable ramp is inactive. If you switch from automatic mode to manual mode during the reference variable ramp is in action, the reference variable ramp is interrupted and the new value of the reference variable is implemented.

If the safety set point W_S is activated by a binary input (see section 3.9.1), this value is assumed in a single step and not gradually. When deactivating W_S , the new value of the reference variable will be used according to the reference variable ramp.

Parameters to be set

Same as for section 6.1

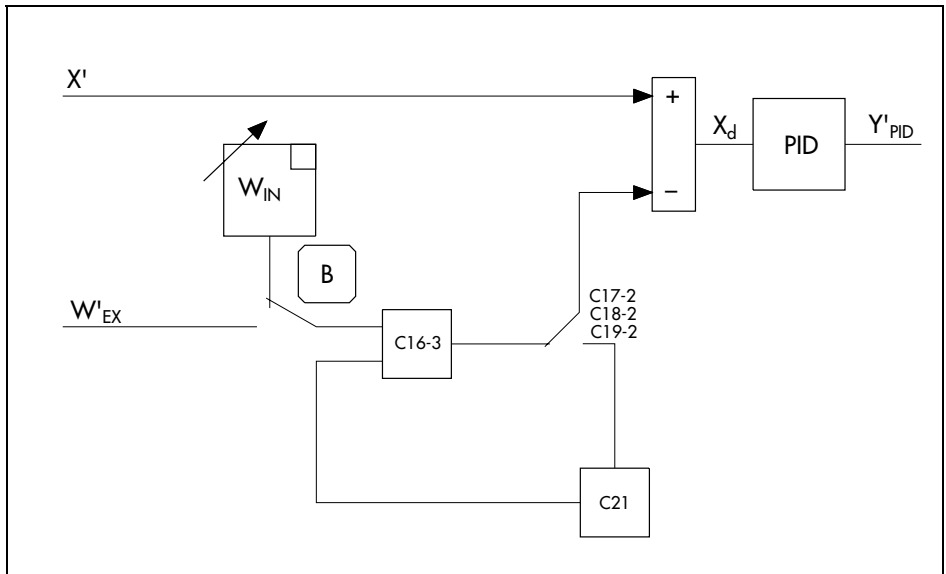

Fig. 55 · Reference variable ramp without starting condition

6.1.3 Continuous increase and decrease in the reference variable (C16-4, C17/18/19-3, C18/19/17-3)

The configuration switch C16-4 enables a reference variable ramp to be initiated for an increasing as well as for a decreasing reference variable by means of two binary inputs. This function can be performed in automatic mode as well as in manual mode. Two binary inputs must be configured for the function "Initializing reference variable ramp", this is for example C17-3 and C18-3 when using the binary inputs bi1 and bi2. The reference variable ramp will then be controlled via the binary inputs as follows:

Binary input bi1	Binary input bi2	Function
On	On	Reference variable W_{IN} or W_{EX} active (key B)
On	Off	Increasing reference variable
Off	On	Decreasing reference variable
Off	Off	Reference variable is stopped at the value attained

Parameters to be set

Same as for section 6.1

6.1.4 Instantaneous increase and decrease in the reference variable (C16-5, C17/18/19-3, C18/19/17-3)

As to its function, the configuration switch C16-5 is comparable to the configuration switch C16-4 described in the previous section. However, in this case, the reference variable is not changed continuously but instantaneously, i.e. suddenly. The magnitude of the steps is determined by the parameter W_{INK2} . W_{INK2} is given in percent with regard to the entire reference variable range. C16-5 also requires the configuration of two binary inputs for the function "Initializing reference variable ramp", this is for example C17-3 and C18-3 when using the binary inputs bi1 and bi2. This function can be performed in automatic mode as well as in manual mode. The increase and decrease in the reference variable will then be controlled via the binary inputs as follows:

Binary input bi1	Binary input bi2	Function
On	On	Reference variable W_{IN} or W_{EX} active (key B)
On	Off	Instantaneous increase in reference variable
Off	On	Instantaneous decrease in reference variable
Off	Off	Reference variable is stopped at the value attained

By quickly opening and closing a binary input, the reference variable can be increased or decreased in the form of steps, provided the second binary input is deactivated.

Parameters to be set

W_{INK2} Range: 0 to 100 %

6.2 Output ramp or limitation of the rate of output changes (C34)

The configuration block C34 implements an output ramp or limits the rate of changes in the output variable(s). This is possible for all control modes for an increasing as well as a decreasing output signal. An output ramp represents the change in the output variable at a constant rate. The parameter $T_S K_1$ determines the run time of the output ramp, and hence its speed. $T_S K_1$ refers to an output change by 100 %, see Fig. 56 .

The output ramp can be started in two ways: 1) cancelling the safety mode via binary input (C34-2/-3/-9/-10) or 2) configuration of a binary input (C34-4/-5/-11/-12).

The limitation of the rate of output changes can be in effect all the time or it can be activated and deactivated via binary input (C34-6/-7/-8/-13/-14/-15). The three different versions of an output ramp will be described in the following sections.

Factory default C34-1 is without an output ramp.

Parameters to be set

$T_S K_1$	Range:	-199	to	-1	in minutes
		0.1	to	1999	in seconds

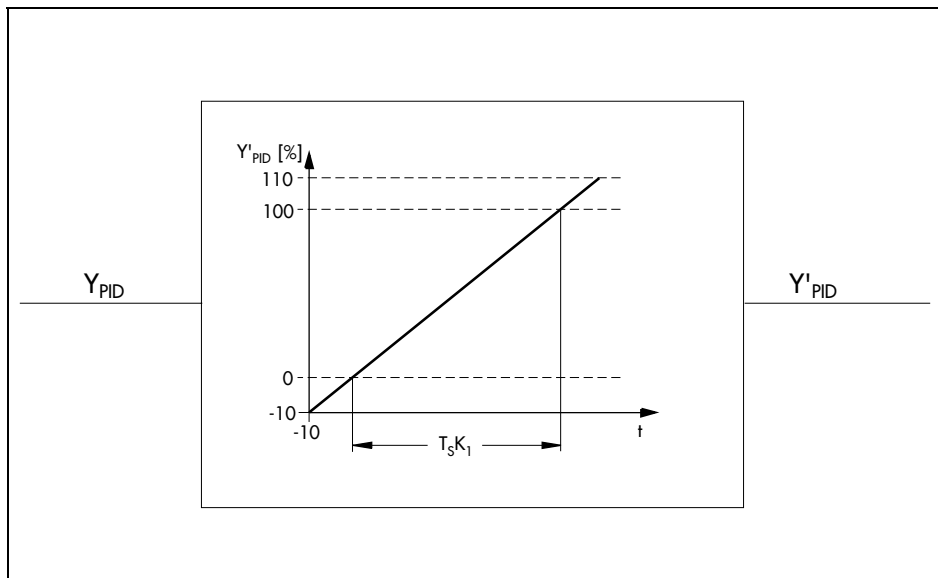

Fig. 56 · Output ramp

6.2.1 Output ramp with starting condition by cancelling the safety mode (C34-2/-3/-9/-10, C17/18/19-6)

The configuration switches **C34-2** and **C34-3** define an output ramp which is started as soon as the safety mode is interrupted by closing a binary input (bi1 or bi2). These configuration switches must be employed together with the setting C17-6 or C18-6 only, see also section 3.9.5. The output ramp is effective for either increasing or decreasing output values. It will be terminated latest if the maximum (110 %) or the minimum (–10 %) value of the output variable has been reached. The maximum and minimum values can additionally be limited by means of output signal limitation, see section 5.5.

The output ramp is interrupted if you switch from automatic mode to manual mode. It is also inactive upon coldstart of the process control station.

C34-2 activates an increasing output ramp. A closed binary input and an increasing output variable causes the output ramp to start from the generated safety output value. It is in action until the output variable reaches its calculated value, however, it will stop in any case as soon as the admissible maximum value of the output variable is reached. When configuring C17-6, C34-2 and C35-5, for example, the output ramp will run from the safety output value Y_{1K1} to $Y_{1\neq}$ maximum after the binary input bi1 has closed. The configuration switches C18-6 and C34-2 have the same effect on Y_{2K1} and $Y_{2\neq}$. The output ramp is not valid for a decreasing output variable.

C34-3 selects a decreasing output ramp. Closing the binary input causes the output ramp to start from the generated safety output value and be in action until the output variable has reached the calculated or the minimum admissible output value. When configuring C17-6, C35-5 and C34-3 for example, the output ramp will run from the safety output value Y_{1K1} to $Y_{1\neq}$ after the binary input bi1 has closed. The configuration switches C18-6 and C34-2 have the same effect on Y_{2K1} and $Y_{2\neq}$. The output ramp is not valid for an increasing output variable.

The configuration switches **C34-9** and **C34-10** also select an output ramp as described for C34-2 and C34-3, however, they are valid for the master controller or the limiting controller. Hence, they can only be activated for cascade control or limiting control. This type of output ramp can only be activated via binary input bi3. To do this, select C19-6. When setting the binary input bi3, the safety output value Y_{1K4} will be initiated at the master controller output or the limiting controller output. When closing bi3, the output ramp starts with the safety output value Y_{1K4} . For **C34-9**, the output ramp is active with increasing output variable until a maximum of 110 % is reached. For **C34-10**, the output ramp is active with decreasing output variable until a minimum of –10 % is reached. C34-9 and C34-10 also cause an interruption of the output ramp when switching to manual mode.

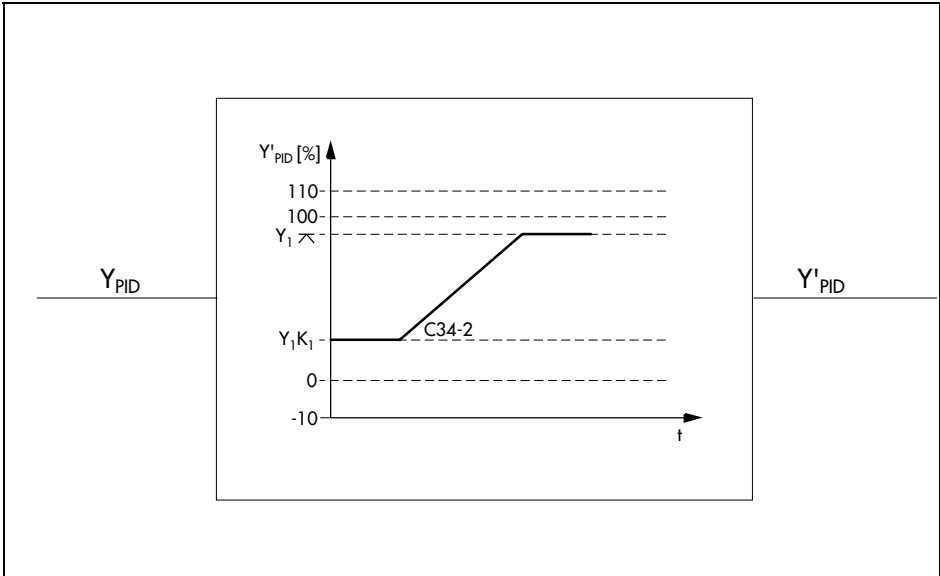

Fig. 57 · Output ramp with starting condition by cancelling the safety mode via C34-2

6.2.2 Output ramp with starting condition via binary input (C34-4/-5/-11/-12, C17/18/19-4)

The configuration switches C34-4, C34-5, C34-11 and C34-12 are used to select an output ramp which is started by a binary input. Therefore, it is required to configure additionally C17-4, C18-4 or C19-4 in order to provide a binary input for this function. To start the output ramp, quickly open and close the binary input by giving a pulse. Depending on the output ramp configured, the value of the output variable, at first, instantaneously assumes the maximum or the minimum output value and finally runs on the calculated value of the output variable at the rate which has been specified by the parameter T_{SK1} .

The output ramp is not active upon a coldstart.

C34-4 configures an increasing output ramp. It starts from the minimum value of the output variable. When switching to manual mode, the output ramp is deactivated.

C34-5 configures a decreasing output ramp. It starts from the maximum value of the output variable. When switching to manual mode, the output ramp is deactivated.

The configuration switches C34-11 and C34-12 can only be selected for cascade control and limiting control. They are valid for the master and the limiting controller. The output ramp functions in the same way as for C34-4 and C34-5.

C34-11 configures an increasing output ramp analogous with C34-4 for the master or the limiting controller.

C34-12 configures a decreasing output ramp analogous with C34-5 for the master or the limiting controller.

6.2.3 Limitation of the rate of output changes (C34-6/-7/-8/-13/-14/-15, C17/18/19-4)

The configuration switches C34-6, C34-7, C34-8, C34-13, C34-14 and C34-15 are used to limit the rate of changes of the output variable. This limitation can be defined for an increasing, for a decreasing or as well for an increasing and decreasing value of the output variable. The output variable changes in the limited direction(s) only as fast as permitted by the parameter T_{SK1} . If the rate of change of the output variable is lower than the defined rate of change, the limitation will be ineffective. In Fig. 58, you will find an example which illustrates the effects of the configuration switches described above.

The rate of changes of the output variable v_y calculates as follows:

$$v_y = \frac{100\%}{T_{SK1}}$$

The limitation of the rate of output changes can be activated and deactivated by a binary input. To do this, the configuration switch C17-4, C18-4 or C19-4 must additionally be selected, see section 3.9.4.

C34-6 and C34-13 limit the rate of changes for increasing values of the output variable. C34-13 is only selectable for cascade control or limiting control and applies to the master or the limiting controller.

C34-7 and C34-14 limit the rate of changes for decreasing values of the output variable. C34-14 can only be selected for cascade control or limiting control and applies to the master or the limiting controller.

C34-8 and C34-15 limit the rate of changes of output variables having increasing as well as decreasing values. C34-15 can be selected for cascade control and limiting control and applies to the master or the limiting controller.

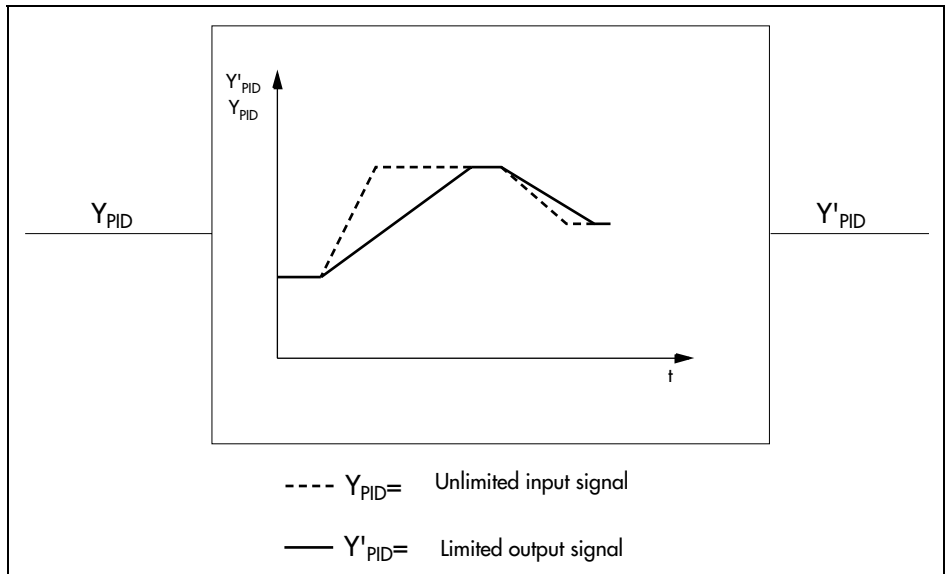

Fig. 58 · Limitation of the rate of output changes via C34-8

7 Additional options of configuration

7.1 Limitation of the reference variable or reciprocal set point or actual value ratio (C20)

The configuration block C20 performs two different functions.

For fixed set point control, follow-up control and synchro control, select the configuration switch **C20-2**. It limits the value of the actual reference variable to $W_{IN}K_1 \neq$ or $W_{IN}K_1 \leq$. If the internal or the external reference variable becomes smaller or larger than $W_{IN}K_1 \neq$ or $W_{IN}K_1 \leq$, the actual value of the reference variable will be set to $W_{IN}K_1 \neq$ or $W_{IN}K_1 \leq$. Note that the value for W_{IN} stored by the process control station may be outside this range! Prior to defining the two parameters $W_{IN}K_1 \neq$ and $W_{IN}K_1 \leq$, select C20-2 in the parameter level.

For ratio control, select the configuration switch **C20-3**. In this setting, calculation is carried out by using the reciprocal set point ratio. This configuration switch is suitable if the input variable is $W_{EX} > X [\%]$, but a ratio larger than 1 shall be set on the display. The actual value ratio also appears in reciprocal form on the display if C4-1 and C4-7 have been set.

7.2 Assignment of the internal reference variable or set point ratio (C22)

The configuration block C22 is used to include the internal reference variable W_{IN} . Follow-up control with external reference variable (FO1) and synchro control (SY) do not use an internal reference variable, hence, this configuration block cannot be selected for those control modes. The configuration switch **C22-1** is factory default and does not assign an internal reference variable.

C22-2 can only be selected for follow-up control FO2 and ratio control RC2. In this setting, the value of the internal reference variable is constantly overwritten by the value of the external reference variable as long as the external reference variable is active.

C22-3 locks the adjustment of the internal reference variable via keys C and D in the operating level. In this case, W_{IN} can only be modified in the parameter level. In cascade control with internal reference variable KA1, this applies to the internal reference variable of the master or the limiting controller. C22-3 cannot be used for follow-up control FO1, cascade control CA2 and synchro control.

C22-4 to C22-8 can only be selected for follow-up control with internal/external reference variable changeover FO2. As long as the external reference variable is active, the values of the internal and external reference variable are linked, as is listed below, to result in the actual value of the external reference variable.

C22-4 $W_{EX} + W_{IN}$

C22-5 $W_{EX} - W_{IN}$, for $W_{IN} > W_{EX}$ or for C20-2 $W_{IN}K_1 \leq$, the reference variable will be 0

C22-6 $W_{IN} - W_{EX}$, for $W_{EX} > W_{IN}$ or for C20-2 $W_{IN}K_1 \leq$, the reference variable will be 0

C22-7 Comparison between W_{EX} and W_{IN} (selection of max. reference variable):

W_{IN} , if $W_{IN} > W_{EX}$

W_{EX} , if $W_{EX} > W_{IN}$

C22-8 Comparison between W_{EX} and W_{IN} (selection of min. reference variable):

W_{IN} , if $W_{IN} < W_{EX}$

W_{EX} , if $W_{EX} < W_{IN}$

C22-9 to C22-13 can only be selected in cascade control mode (CA1 or CA2). They have been described in section 4.4.2.

Note:

The safety output value W_S overwrites the value of the internal reference variable when activating the binary input by C17-/18- or 19-2 together with C21-4, see section 4.4.2.

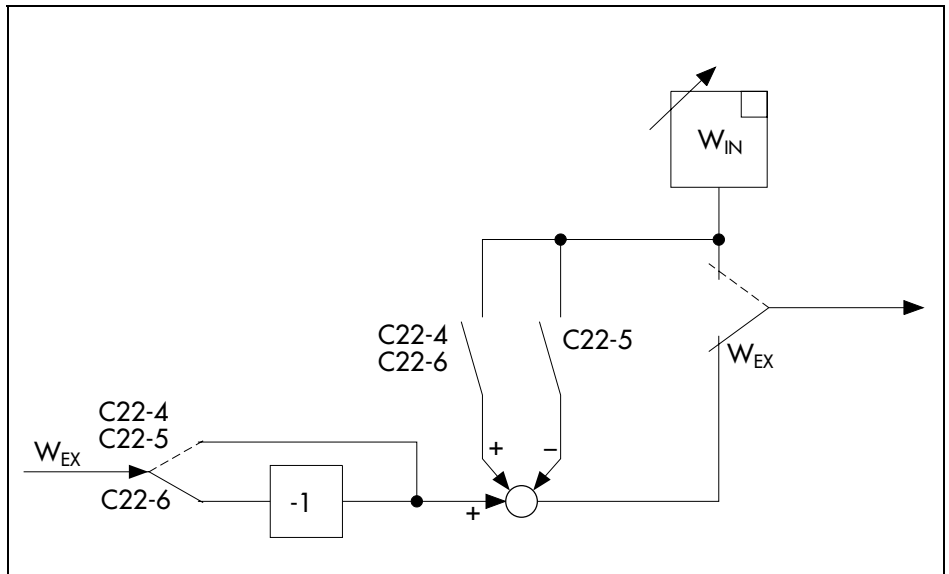

Fig. 59 · Assignment of internal reference variable via C22-4/-5/-6

7.3 X-tracking (C23)

The configuration switch C23 can activate or deactivate X-tracking.

C23-1 is factory default, i.e. X-tracking is deactivated. X-tracking must be deactivated if a reference variable ramp is set via C16-2 or if an internal output signal limitation is set via $C33 \geq 8$.

If X-tracking is activated (**C23-2**) and an internal reference variable is also activated, the internal reference variable is constantly overwritten, i.e. corrected, by the actual value of the controlled variable when in manual mode. As a result, error is always zero. In cascade control mode CA1, the internal reference variable of the master controller is corrected.

Follow-up control (FO1) and cascade control with external reference variable CA2 as well as synchro control (SY) do not use an internal reference variable, hence, this configuration block cannot be selected for those control modes.

7.4 Dynamic behavior of controller outputs (C24, C25)

The configuration blocks C24 and C25 assign different types of dynamic behavior concerning control algorithm to the process control station. The configuration block C25 can only be activated in cascade control mode (CA1 or CA2), it assigns a certain dynamic behavior to the master controller. The dynamic behavior of the follower controller is determined by C24.

In factory default, the process control station is assigned to PI action (24-2). In cascade control mode, the master controller is assigned to P action (25-1) and the follower controller to PI action (24-2).

In the parameter level, you can modify the parameters which are active for the dynamic behavior adjusted. Apart from the common dynamic behaviors P, PI, PD, PID and I, the configuration switch C24-5 makes also P²I action available. When selecting the configuration switches C24/C25-7/-8 or -10, the I action component is adapted to the output variable.

7.4.1 P controller (C24-1, C25-1)

C24-1 is used to set up the process control station as P controller (proportional controller). The master controller in cascade control (CA1 or CA2) is adjusted to proportional action via C25-1.

The output variable of the P controller is proportional to error. The P controller is therefore a very fast controller. Proportional control causes system deviation.

Define the parameter proportional-action coefficient K_P in the parameter level.

Parameters to be set

K_P	Range:	0.1	to	100.0
K_I	Range:	-110	to	110.0 %

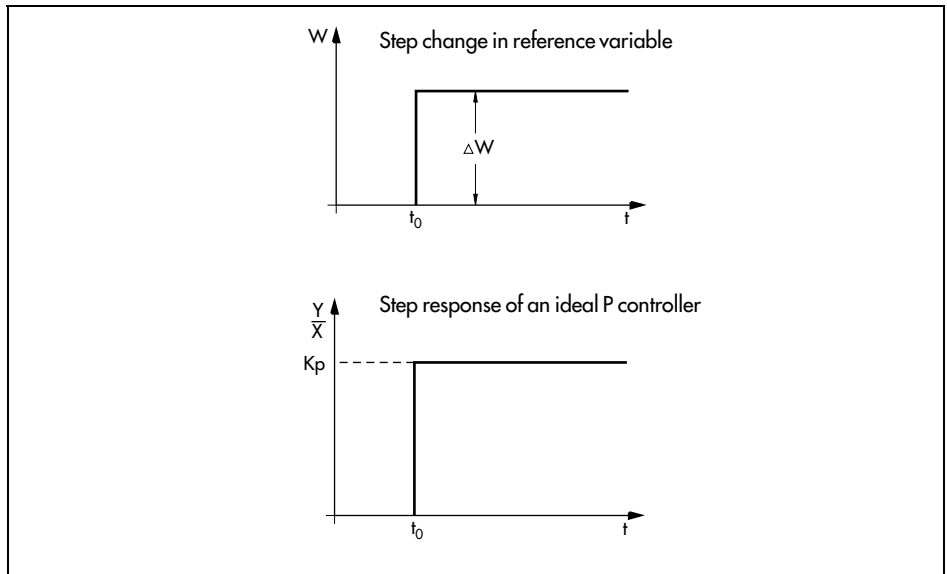

Fig. 60 · P controller

7.4.2 PI controller (C24-2/C25-2)

The PI controller (proportional-plus-integral controller) is selected by C24-2. The master controller in cascade control mode (CA1 or CA2) is adjusted to PI action via configuration switch C25-2 .

The PI controller reacts at first the same way the P controller does. It has an output signal change that is proportional to error. In the end, however, it is the speed of its output signal change which will be proportional to error. Due to the integral-action component included, error is completely compensated.

Define the proportional-action coefficient K_p and the reset time T_N in the parameter level.

Parameters to be set

K_p	Range:	0.1	to	100.0
T_N	Range:	-199	to	-1 in minutes
		1	to	1999 in seconds

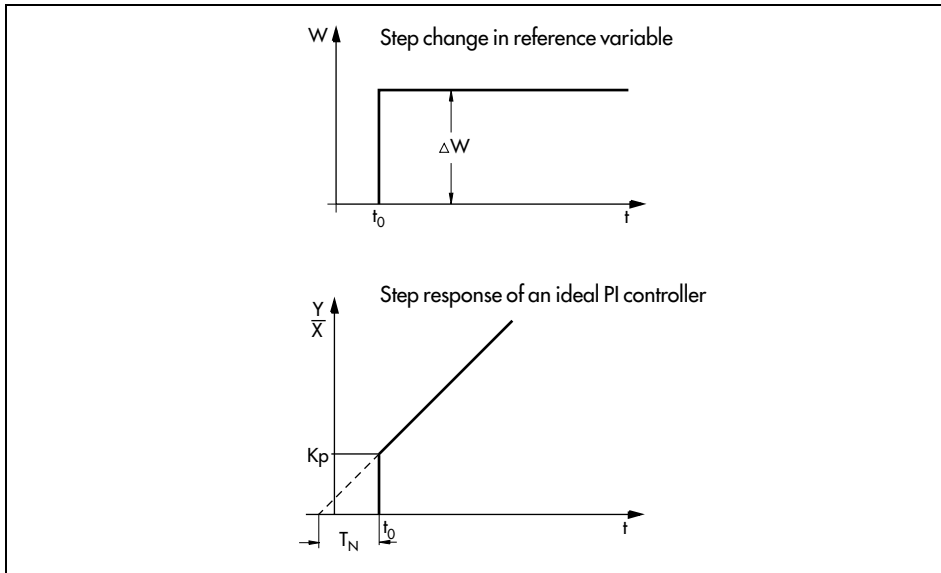

Fig. 61 · PI controller

7.4.3 PD controller (C24-3/C25-3)

The configuration switch C24-3 is used to set up the process control station as PD controller (proportional-plus-derivative controller). The configuration switch C25-3 adjusts the master controller (in CA1 or CA2) to PD action.

Apart from the proportional-action component, the PD controller additionally comprises a derivative-action component. This component changes the output variable by an amount which is proportional to the rate of changes of the controlled variable. The PD controller causes system deviation.

Enter the proportional-action coefficient K_p as well as the derivative-action time T_v . For the D element, you also have to define the derivative-action gain $T_v K_1$. It determines the magnitude of the pulse of the D element.

Parameters to be set

K_p	Range:	0.1	to	100.0
T_v	Range:	-199	to	-1 in minutes
		1	to	1999 in seconds
$T_v K_1$	Range:	0.1	to	10.0
K_1	Range:	-110	to	110.0 %

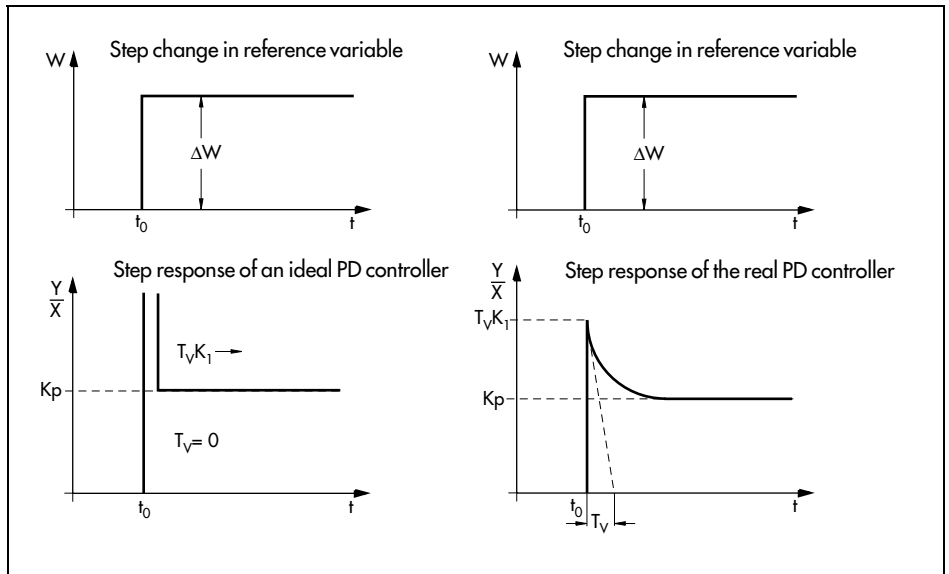

Fig. 62 · PD controller

7.4.4 PID controller (C24-4/C25-4)

The configuration switch C24-4 is used to select a PID controller (proportional-plus-integral-plus-derivative controller). The configuration switch C25-4 adjusts the master controller (in CA1 or CA2) to PID action.

A PID controller is made up of a PI controller and a derivative-action element.

Adjust the parameters, proportional-action coefficient K_p , reset time T_N , derivative-action time T_V and derivative-action gain $T_V K_1$.

Parameters to be set

K_p	Range:	0.1	to	100.0
T_V	Range:	-199	to	-1 in minutes
		1	to	1999 in seconds
$T_V K_1$	Range:	0.1	to	10.0
T_N	Range:	-199	to	-1 in minutes
		1	to	1999 in seconds

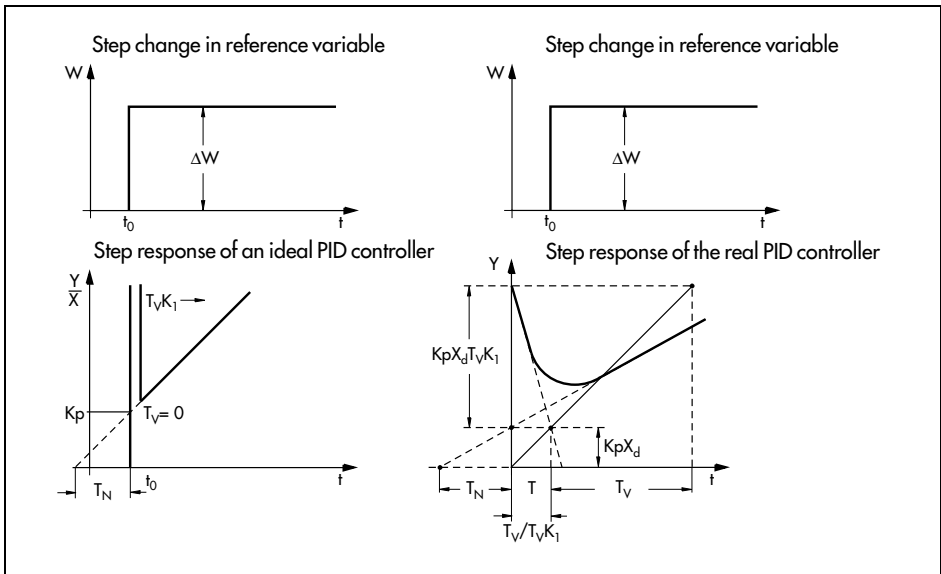

Fig. 63 · PID controller

7.4.5 P²I controller (C24-5, C25-5)

The configuration switch C24-5 selects the P²I controller. Setting the configuration switch C25-5, the master controller (in CA1 or CA2) is adjusted to P²I action.

In this control algorithm, error is squared before acting on the P element. The integral element operates on single error.

Enter the proportional-action coefficient K_p and the reset time T_N in the parameter level.

Parameters to be set

Same as for PI controller in section 7.4.2

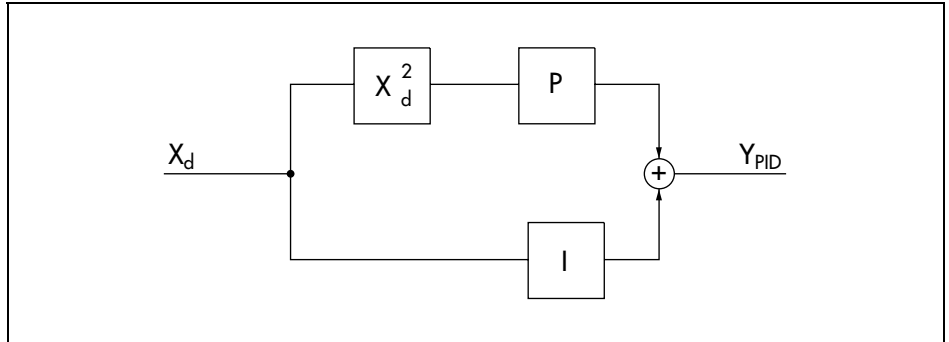

Fig. 64 · P²I controller

7.4.6 Integral controller (C24-6, C25-6)

The configuration switch C24-6 selects the integral (reset) controller. This type of control action may also be selected for the master controller in cascade control mode via C25-6.

Define the reset time T_N in the parameter level.

Parameters to be set

T_N	Range:	-199	to	-1	in minutes
		1	to	1999	in seconds

7.4.7 PI, PID and integral controller with correction of the integral-action component (C24-7/-8/-10, C25-7/-8/-10)

The configuration switch C24-7 determines PI action, C24-8 determines PID action and C24-10 integral action. The difference between them and the PI, PID and integral controllers mentioned above is that, in this case, the integral-action component is adapted to the output variable. This means that the Y_{PID} signal is limited to the maximum or minimum value of the output variable. As a result, time advantages can be gained for the output variable reaction. In cascade control mode, the configuration block C25 must be set to adjust the master controller correspondingly.

Parameters to be set Same as for sections 7.4.2, 7.4.4 or 7.4.6.

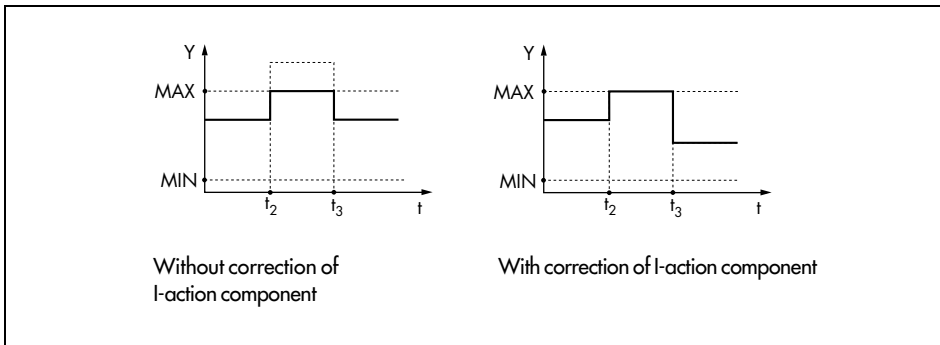

Fig. 65 · Integral-action component correction

7.5 Input variable for the D element (C26)

With adjusted dynamic behavior including derivative action (see section 7.4), you have the possibility of defining different input variables for the D element via configuration block C26. The following input variables may be defined: error via **C26-1**, the actual value of the controlled variable via **C26-2** or the controlled variable via **C26-3**.

If you have selected error, the process control station reacts to a fast change over time in the controlled variable, the reference variable or the disturbance variable, issuing a D-action step response.

When selecting the actual value, the process control station reacts to a fast change over time in the controlled variable or the disturbance variable, producing a D-action step response.

Selecting the controlled variable, the process control station reacts to a fast change over time in the controlled variable, issuing a D-action step response. Changes in the disturbance variable or in the reference variable are not considered by the D-action component.

If a D-action component has been selected in cascade control mode for the master or the limiting controller or for the follower the primary controller, or finally for both, the input variable for the D element can be defined for the master or the limiting controller as well as for the follower or the primary controller. Refer to the configuration table to select an appropriate combination from the three possible input variables (**C26-1 to C26-9**). Factory default is C26-1, i.e. the input variable for the D element is error X_d , applying to the master or the limiting controller as well as to the follower or the primary controller. If only one controller of the cascade has dynamic behavior with a D-action component, the input variable of the controller without D action will be ignored.

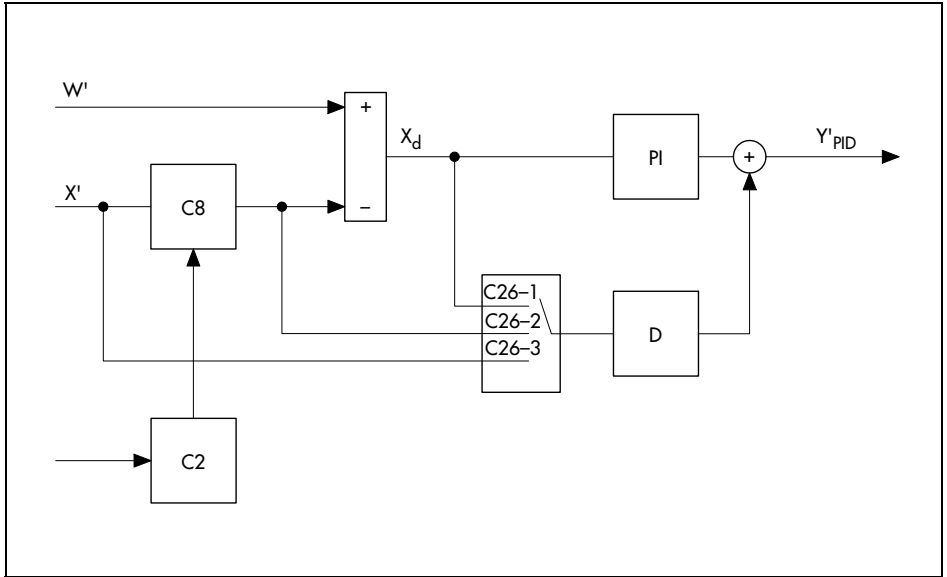

Fig. 66 · Input variable for D element in fixed set point, follow-up, ratio and synchro control mode

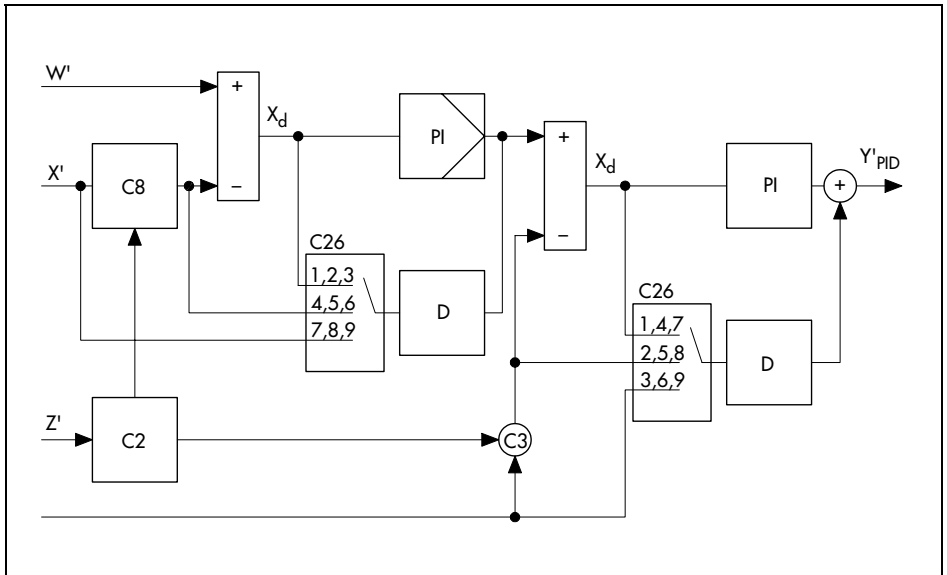

Fig. 67 · Input variable for D element in cascade control mode

7.6 Operating point adjustment (C28, C30)

If the process control station is set up to be a P or PD controller (C24-1/3 and C25-1/3), the operating point adjustment can be carried out in two ways: in manual mode via configuration block C28 and by using the reference variable via configuration block C30. These operating points are independent of the operating point adjusted by the parameter K_1 . K_1 has an additional effect as offset in this configuration. The operating point is added to the output signal in order to make the system deviation zero. The two types of operating point adjustment will be presented to you in the following sections.

7.6.1 Operating point adjustment via manual mode (C28)

The configuration switch C28-2 activates operating point adjustment via manual mode. In factory default C28-1, operating point adjustment via manual mode is not activated. The principle of this function is as follows: In manual mode, you have to adjust the output variable to the desired value via keys [G] and [F]. When switching to automatic mode, the last value of the output variable is stored as operating point and added to the output variable which has been calculated by the P or PD algorithm. This operating point remains active until either the the function operating point adjustment via manual mode is deactivated via configuration switch C28-1 or until a new operating point is adjusted in the manual mode.

If the function 'operating point adjustment via manual mode' is deactivated via configuration switch C28-1, the output variable fixed by the keys [G] and [H] will be brought to the calculated value within approx. 2 seconds.

In cascade or limiting control mode, the operating point adjustment via manual mode acts on the follower controller.

7.6.2 Operating point adjustment via reference variable (C30)

The configuration block C30 is used to activate and deactivate the operating point adjustment via reference variable. This is not provided in factory default (C30-1). The configuration switch C30-2 activates operating point adjustment via reference variable. It cannot be activated with an active reference variable ramp (C16>2), with dynamic behavior including I-action component (C24/C25-2/-4/-7/-8/-10) or operating point adjustment via manual mode (C28-2).

When adjusting the operating point via reference variable, the currently active reference variable (external or internal reference variable or safety set point) is added to the output variable that has been calculated by the control algorithm.

If, in automatic mode, different reference variables are used and exchanged for each other, the output variable can react in the form of steps due to the different operating points.

When switching from manual to automatic mode, the difference between the calculated output variable and the one defined in manual mode ($Y_{PD} - Y_{\text{man}}$) will be compensated within approx. 2 seconds.

In cascade control mode, the operating point adjustment acts on the master controller.

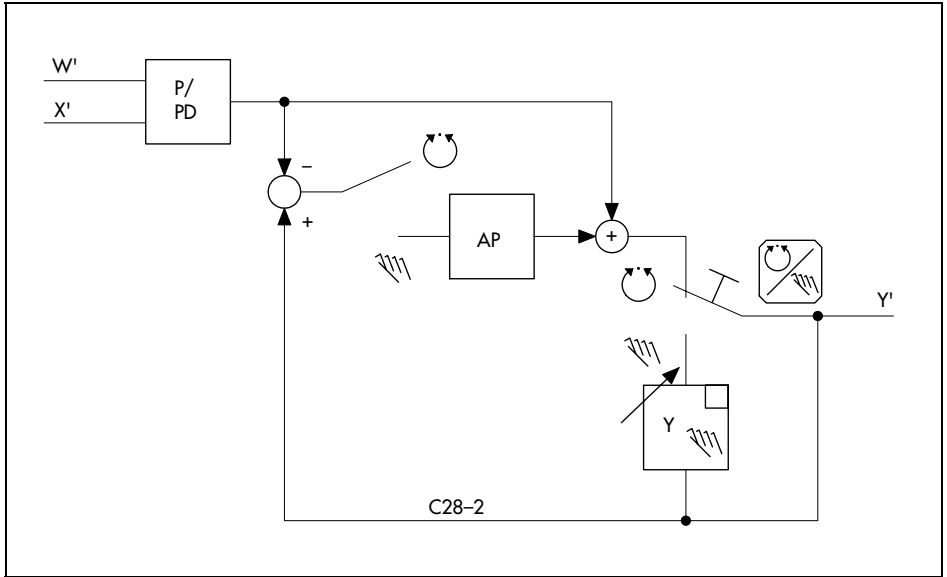

Fig. 68 · Operating point adjustment via manual mode using C28-2

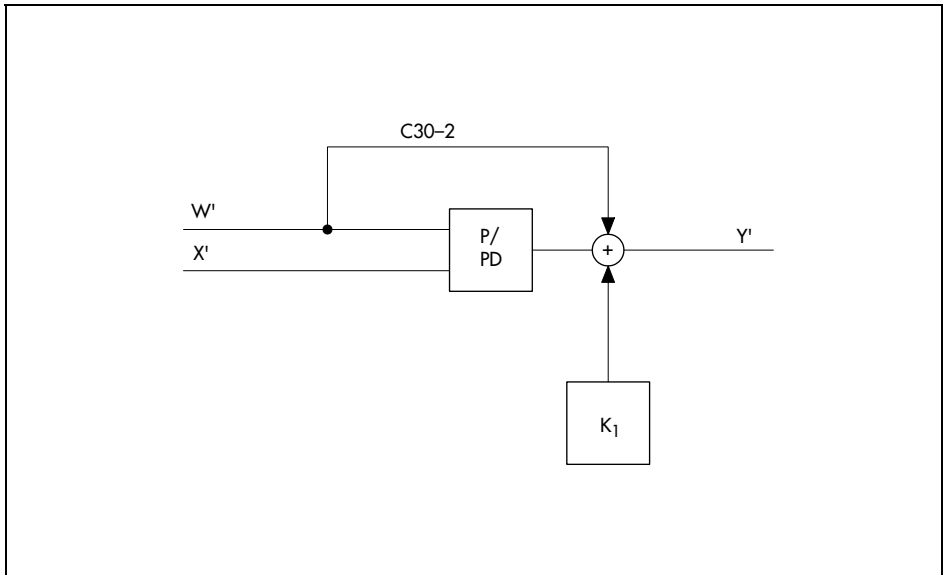

Fig. 69 · Operating point adjustment via reference variable using C30-2

7.7 Change of control action (C29)

Change of control action allows the process control station to be operated, in different operating states, using different types of dynamic behavior regarding the control algorithm. The TROVIS 641 2 Process Control Station includes three varying types of control action changes: P(D)/PI(D) action, Y_0 /PI(D) action and Y_{max} / Y_0 /PI(D) action. They will be described in the following sections.

In factory default C29-1, the change of control action is deactivated.

Employing change of control action, generally makes sense only if an integral-action component has been added via configuration block C24 (dynamic behavior).

7.7.1 P(D)/PI(D) control action (29-2/-3/-4)

The configuration switch **C29-2** activates P(D)/PI(D) action. In cascade control mode, this is used to determine this type of change of control action for the follower or the primary controller. If you want to apply this change of control action to the master or the limiting controller, select **C29-3**. If this is wished for both the follower and the master controller or the primary and the limiting controller, then select **C29-4**.

In P(D)/PI(D) control action, the current output variable determines whether P (or PD) or PI (or PID) control action will be activated. When outside the definable range of the output variable, the P or PD control action parameters are implemented, when inside the definable range, the I-action component will be in effect. The range of the output variable mentioned right above is specified by the parameters GWK₃ and GWK₄. In cascade control mode, GWK₃ and GWK₄ determine the range for the follower controller. The master controller has its range determined by the parameters GWK₅ and GWK₆. Fig. 70 clearly shows this output variable range.

Parameters to be set

GWK ₃ , GWK ₄	Output variable range	Range:	0.0	to	110.0 %
GWK ₅ , GWK ₆	For CA1 and CA2, output variable range for master controller	Range:	0.0	to	110.0 %

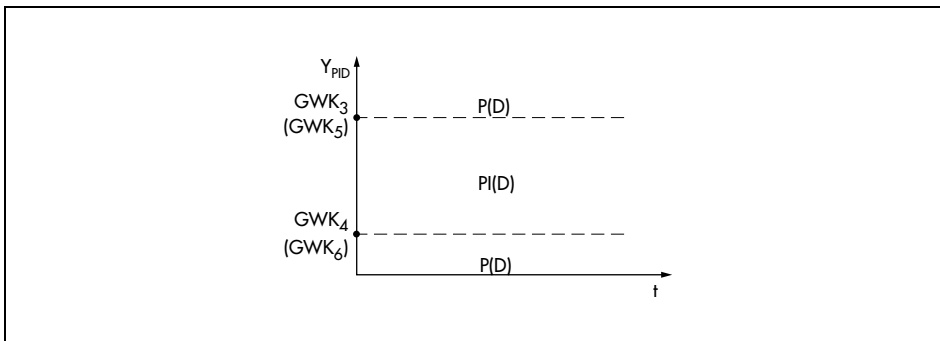

Fig. 70 · Determination of output variable range for P(D)/PI(D) change of control action

7.7.2 $Y_0/PI(D)$ control action (29-5/-6/-7)

$Y_0/PI(D)$ action provides a value (Y_0) of the output variable that must be defined in a definable error range. Beyond this range, the controlled system runs on the configured PI or PID action. The range of error in which the PID algorithm does not intervene is determined by the parameter GWK_3 . The output value Y_0 can either be specified by the parameter K_6 , by the input W_{EX} or the input Z . Transition from the open-loop control range (controlled by Y_0) to the closed-loop control range causes a ramp function to become active. This ramp function is an exponential function the time constant of which you have to determine by the parameter TsK_2 .

C29-5 determines the Y_0 value via K_6 . This configuration switch can be selected for all control modes. In cascade control mode, this configuration applies to the follower or the primary controller.

C29-6 uses the input W_{EX} to determine the Y_0 value. This configuration switch can only be selected in fixed set point control mode and in cascade control mode with internal reference variable $CA1$, applying to the follower or the primary controller.

C29-7 uses the input Z to determine the Y_0 value. C29-7 cannot be selected in ratio control mode $RC2$ and cascade control modes $CA1$ and $CA2$.

Parameters to be set

GWK_3	X_d range for Y_0 control	Range:	0.0 to 110.0 %
K_6	Y_0 value (only for C29-5)	Range:	0.0 to 110.0 %
TsK_2	Time constant	Range:	-199 to -1 in minutes 1 to 1999 in seconds

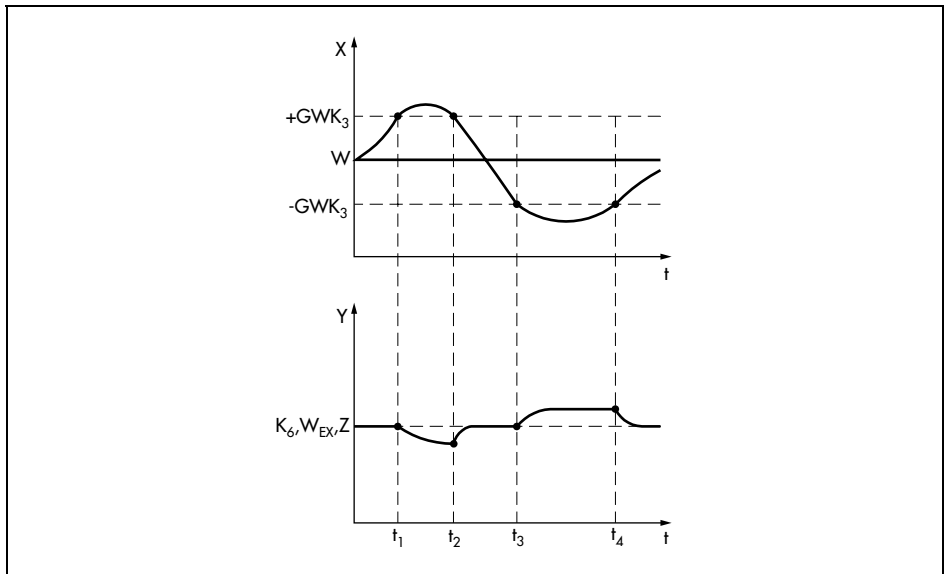

Fig. 71 · $Y_0/PI(D)$ change of control action

7.7.3 $Y_{\max}/Y_0/PI(D)$ control action (29-8/-9/-10)

This control mode is ideally suitable for fast start-up of a control loop. Starting point is a definable value Y_{\max} of the output variable which is determined by the parameter GWK_5 . If error falls below the first limit value definable by parameters, the system switches instantaneously to the value Y_0 of the output variable which is also definable. This value may be determined either by the parameter K_6 , or the input W_{EX} or else the input Z . If error falls below the second limit value definable by parameters, the process control station switches smoothly to the configured control action (C24). The first limit value for error is fixed by the parameter GWK_4 , the second one by the parameter GWK_3 . Fig. 72 illustrates how the $Y_{\max}/Y_0/PI(D)$ change of control action functions.

C29-8 uses K_6 to determine the Y_0 value. This configuration switch can be selected in all control modes and applies to the follower or the master controller in the cascade control mode.

C29-9 uses the input W_{EX} to determine the Y_0 value. This configuration switch is only selectable for fixed set point control and for cascade control with internal reference variable $CA1$, applying in this case to the follower or the master controller.

C29-10 uses the input Z to determine the Y_0 value. Selecting C29-10 is not possible for ratio control $RC2$ and for the cascade control modes $CA1$ and $CA2$.

A binary input can be used to switch the $Y_{\max}/Y_0/PI(D)$ change of control action on and off (C17/18/19-15), see section 3.9.15.

Parameters to be set

GWK_3, GWK_4	Limit values of error	Range:	0.0 to 110.0 %
GWK_5	Y_{\max} value		
K_6	Y_0 value (only for C29-8)	Range:	0.0 to 110.0 %

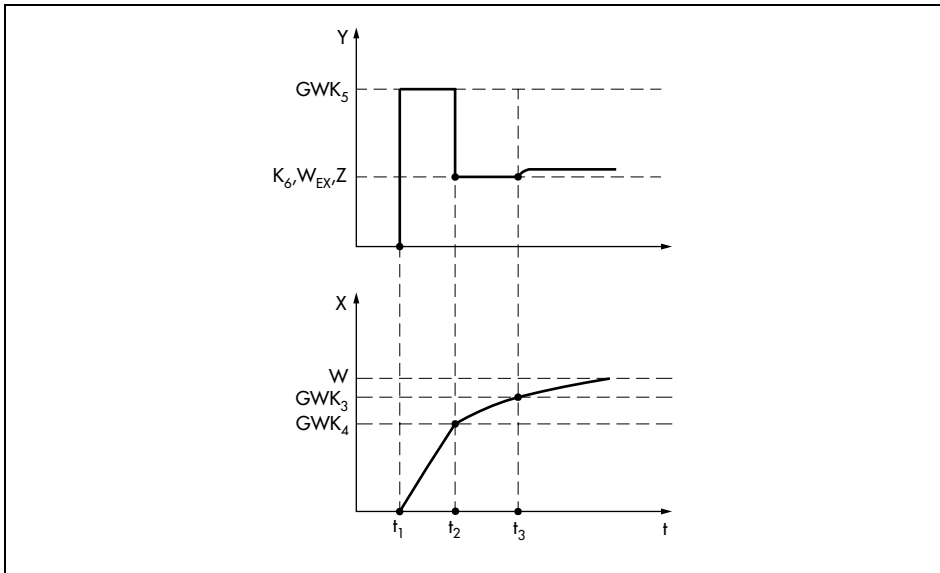

Fig. 72 · $Y_{\max}/Y_0/PI(D)$ change of control action

7.8 Restart conditions upon power supply failure (C43)

The configuration block C43 is used to determine the behavior of the process control station after power supply failure. C43 is described in detail in the Mounting and operating instructions EB 6412 EN in the section "Power supply failure". Moreover, section 3.9.5 describes the output variables issued upon power supply failure (safety output values).

7.9 Power frequency (C49)

The power frequency can be adapted via configuration block C49, if needed. It is adjusted to 50 Hz via **C49-1**. This setting is also suitable for dc voltage. If you wish to set a frequency of 60 Hz, select the configuration switch **C49-2**.

7.10 Adaptation of the measuring range of W_{EX} input to the range of X input (C53)

The configuration switch **C53-2** is used to adapt the measuring range of the input signal W_{EX} to that of the input signal X. In Fig. 73, an example is given to show the effect of this function. The measuring range adjusted for W_{EX} = -20 to 50 and for X = 0 to 40.

C53-1 does not carry out measuring range adaptation.

The configuration block C53 can only be configured for follow-up control FO1 and FO2 as well as for cascade control CA2.

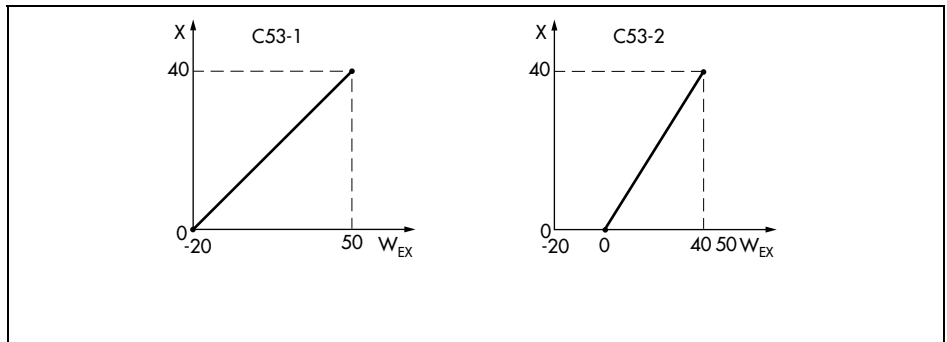

Fig. 73 · Example for measuring range adaptation of W_{EX} input to X input

7.11 Reset to factory default (C56)

The configuration block C56 is used to reset parameters, configuration blocks, zero and span of the analog inputs and outputs, adaptation parameters, code numbers and finally the controller ID number of the process control station to factory default. This has been explained in detail in the Mounting and operating instructions EB 6412 EN in the section "Ini level".

8 Display functions

The functions described in this section change the variables displayed on the process control station. They ensure the display can be adapted to special requirements by using additional symbols, by changing the variables on the display or by modifying the repetition rates. The configuration switches described do not affect the controller functions of the process control station!

8.1 Configuration of digital displays (C4)

The configuration block C4 is used to configure the upper and lower display field. Generally, the upper display field reads the reference variable and the lower field the controlled variable, with the exception of C4-6 for ratio control. The two variables are sensed in different processing stages to be then displayed. The diagrams in the following sections will give a schematic presentation on this. The configuration of the digital display will be described for each control mode individually. Factory default is always C4-1.

Please note that a binary input may be used to switch between two display modes. This has been described in section 3.9.12 on page 33 .

8.1.1 Configuration of digital displays in fixed set point control mode (C4)

In fixed set point control mode, the upper display field can show the following values, see Fig. 74 :

- the value W_{IN} of the internal reference variable,
- the value S_1 of the internal reference variable directly transmitted to the comparator.

The lower display field indicates

- the controlled variable X' after having passed the input circuitry,
- the actual value I_1 of the controlled variable at the comparator,
- the standardized actual value I_n of the controlled variable.

The configuration required for this purpose is listed in the table below:

C4	C4-1	C4-2	C4-3	C4-4	C4-5	C4-6	C4-7
Upper digital display	S_1	S_1	-	-	S_1	-	W_{IN}
Lower digital display	I_1	X'	-	-	I_n	-	I_1

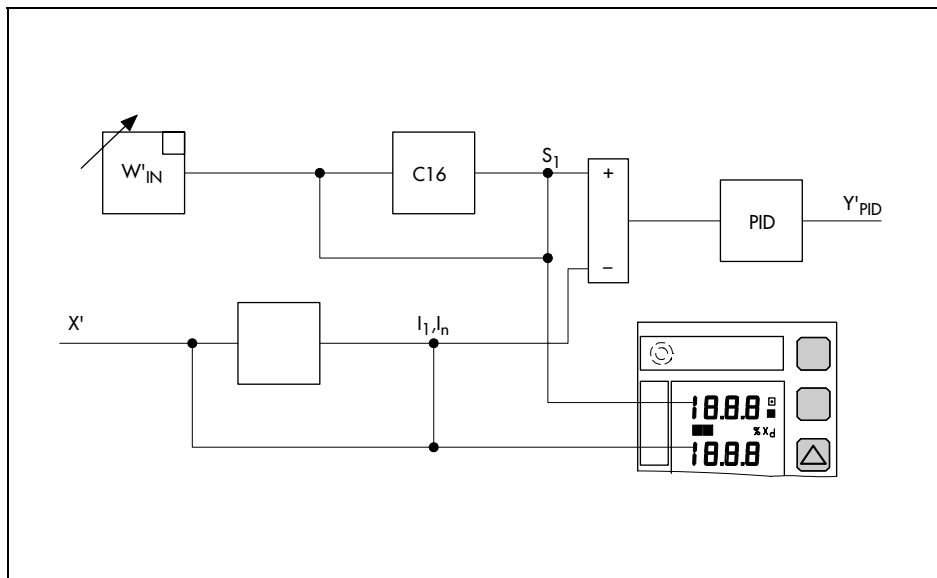

Fig. 74 · Digital displays in fixed set point control mode

8.1.2 Configuration of digital displays in follow-up control mode (C4)

In follow-up control mode, the upper display field can show the following values, see Fig. 75 :

- the value W'_{EX} of the external reference variable after having passed the input circuitry,
- the value S_3 of the reference variable before entering the reference variable ramp,
- the value S_1 of the reference variable directly transmitted to the comparator.

The lower display field indicates

- the controlled variable X' after having passed the input circuitry,
- the actual value I_1 of the controlled variable at the comparator,
- the standardized actual value I_n of the controlled variable .

The configuration required for this purpose is listed in the table below:

C4	C4-1	C4-2	C4-3	C4-4	C4-5	C4-6	C4-7
Upper digital display	S_1	S_1	W'_{EX}	W'_{EX}	S_1	-	S_3
Lower digital display	I_1	X'	I_1	X'	I_n	-	I_1

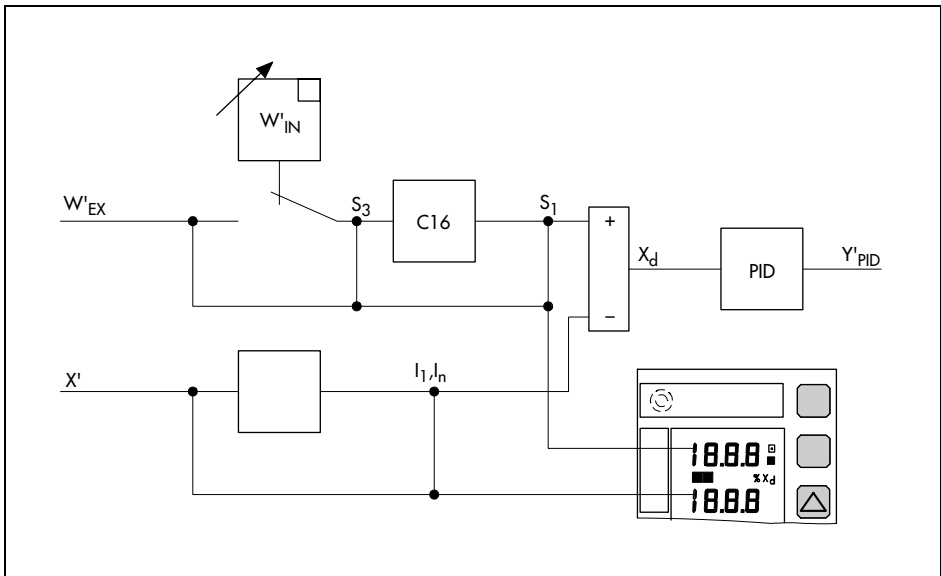

Fig. 75 · Digital displays in follow-up control mode

8.1.3 Configuration of digital displays in ratio control mode (C4)

In ratio control mode, the upper display field can show the following values, see Fig. 76 :

- the value W'_{EX} of the leading variable after having passed the input circuitry,
- the set point V_2 of the ratio (i.e. Z' or W'_{IN}) before entering the reference variable ramp,
- the set point V of the ratio after completion of the reference variable ramp.

The lower display field indicates

- the input variable X' after having passed the input circuitry,
- its actual value I_1 at the comparator,
- the actual value ratio I_V (X'/W'_{EX}), or for C20-3 the reciprocal actual value ratio,
- the value W'_{EX} of the leading variable after having passed the input circuitry.

The configuration required for this purpose is listed in the table below:

C4	C4-1	C4-2	C4-3	C4-4	C4-5	C4-6	C4-7
Upper digital display	V	-	W'_{EX}	W'_{EX}	-	V	V_2
Lower digital display	I_V	-	I_1	X'	-	W'_{EX}	I_V

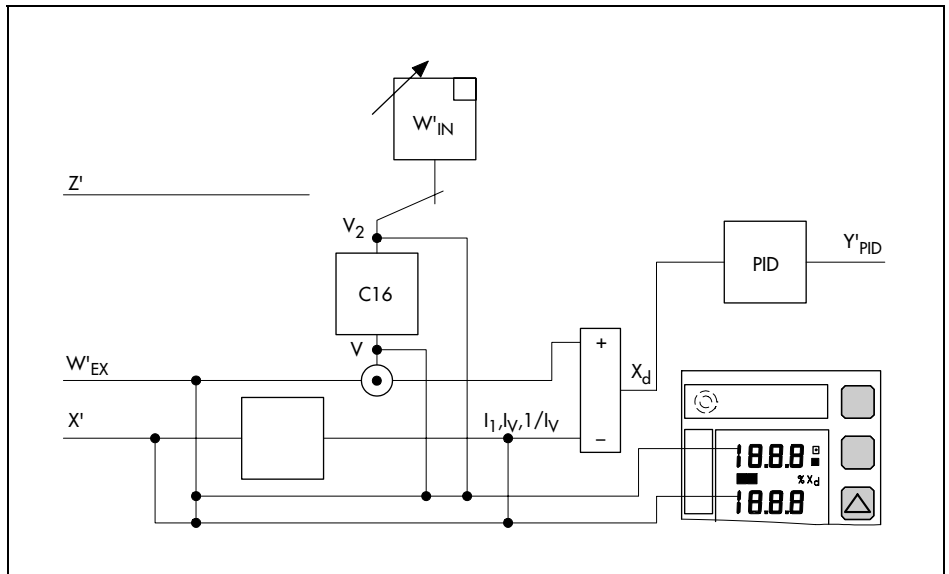

Fig. 76 · Digital displays in ratio control mode

8.1.4 Configuration of digital displays in cascade control mode (C4)

In cascade control mode, C4 is used to adjust the display for the master or the limiting controller as well as for the follower or the primary controller. Pressing the key B interrupts or closes the cascade. At the same time, the digital display switches between the values of the master/limiting controller and the slave/primary controller. In some settings of C4, the digital display can be changed via key F without interrupting the cascade, see Table below. The values of the slave/primary controller are marked by the symbol ■ to the right of the upper display field. If the cascade is closed and, hence the master/limiting controller is active, this symbol is hidden.

Master/limiting controller:

The upper display field can show the following values:

- the value W'_{EX} of the external reference variable after having passed the input circuitry (only CA2),
- the value S_3 of the reference variable before entering the reference variable ramp,
- the value S_1 of the reference variable directly transmitted to the comparator.

The lower display field indicates

- the controlled variable X' after having passed the input circuitry or
- the actual value I_1 of the controlled variable at the comparator.

Slave/primary controller:

The upper display field can show the following values:

- in all settings the last value of the reference variable S_2 at the comparator of the follower or the primary controller after interruption of the cascade.

The lower display field indicates

- the value Z' of the controlled variable after having passed the input circuitry,
- the actual value I_2 of the controlled variable at the comparator.

	C4	C4-1	C4-2	C4-3 ²⁾	C4-4 ²⁾	C4-5 ^{1), 2)}	C4-6 ^{1), 2)}	C4-7
Master controller	Upper digital display	S_1	S_1	S_1	S_1	W'_{EX}	W'_{EX}	S_3
	Lower digital display	I_1	X'	I_1	X'	I_1	X'	I_1
Follower controller	Upper digital display	S_2	S_2	S_2	S_2	S_2	S_2	S_2
	Lower digital display	I_2	Z'	I_2	Z'	I_2	Z'	I_2

¹⁾ Only for CA2 (C1-11)

²⁾ Switching between digital displays also possible via key F

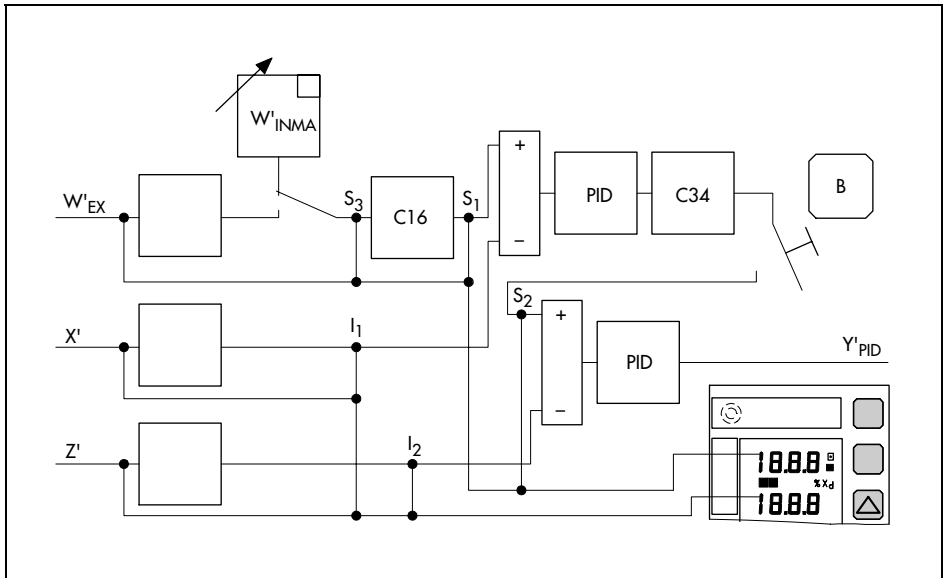

Fig. 77 · Digital displays in cascade control mode

8.1.5 Configuration of digital displays in synchro control mode (C4)

In synchro control mode, the upper display field can show the following values, see Fig. 78 :

- the value W'_{EX} of the external reference variable after having passed the input circuitry,
- the value S_3 of the reference variable before entering the reference variable ramp,
- the value S_1 of the reference variable directly transmitted to the comparator.

The lower display field indicates

- the controlled variable X' after having passed the input circuitry,
- the actual value I_1 of the controlled variable at the comparator.

The configuration required for this purpose is listed in the table below:

C4	C4-1	C4-2	C4-3	C4-4	C4-5	C4-6	C4-7
Upper digital display	S_1	S_1	W'_{EX}	W'_{EX}	-	-	S_3
Lower digital display	I_1	X'	I_1	X'	-	-	I_1

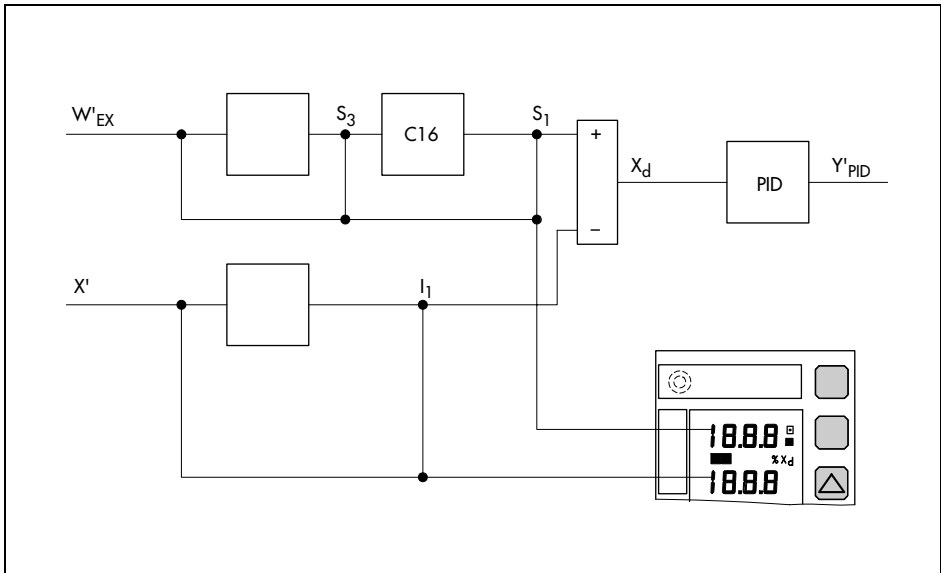

Fig. 78 · Digital displays in synchro control mode

8.2 Assignment of the output variable display (C38)

The configuration block C38 is used to determine the output variable signal Y_1 , Y_2 , Y_{ACTUAT} or Y_{PID} for the bar graph of the output variable and for the numerical display in the upper field by means of key F, see Fig. 79 .

Factory default is C38-1, this means Y_{PID} is displayed in the bar graph as well as in the upper display field.

The other setting options can be found in the configuration table.

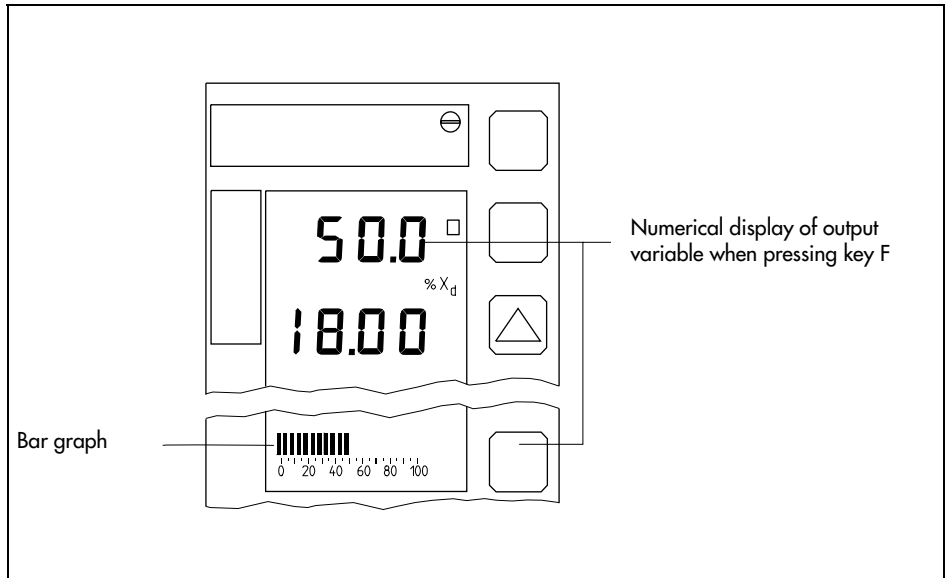

Fig. 79 · Assignment of output variable display

8.3 Inversion of the output variable display (C39)

The configuration block C39 is used to invert the output variable display (bar graph and numerical display in the upper display field, see Fig. 79). This allows to establish a direct relationship with the position of the control valve.

Factory default is C39-1 in which the output variable display is not inverted. The configuration switch C39-2 inverts the output variable display.

8.4 Display of closed position of the control valve (C42)

The bar graph for the output variable can be complemented by the symbol ▼ indicating the control valve is in closed position. This symbol may appear at 0 % when selecting C42-2 or at 100 % when C42-3 has been selected. Factory default is C42-1 in which the symbol ▼ is hidden.

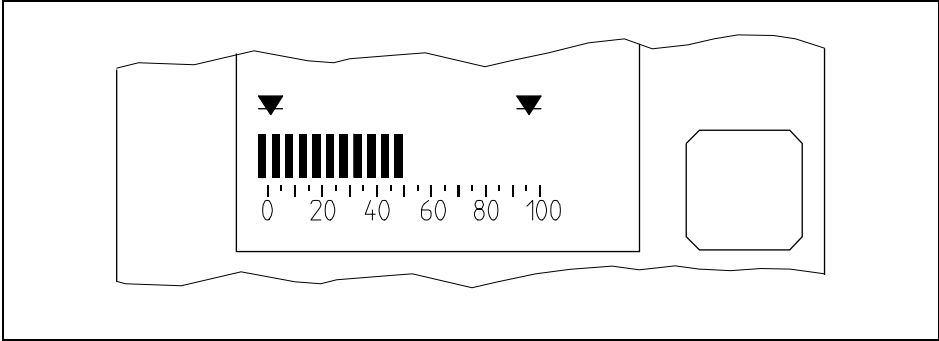

Fig. 80 · Display of closed position of the control valve

8.5 Repetition rate of digital displays and of error display (C46)

The configuration block C46 sets the repetition rate of the digital displays and the error display to 0.1 s (C46-1); 0.2 s (C46-2); 0.5 s (C46-3); 1 s (C46-4); 5 s (C46-5) or 10 s (C46-6).

Factory default is a repetition rate of 0.1 s (C46-1).

Quickly changing displays are easier to read when increasing the repetition rate.

8.6 Display range of error (C47)

This configuration block determines the display range for the bar graph of error. It can be adjusted to $\pm 6\%$ (C47-2), $\pm 12\%$ (C47-3) or $\pm 30\%$ (C47-4). If the bar graph tends to be at full-scale deflection all the time, it is recommended to increase the display range.

Factory default is C47-2.

8.7 Decimal point on digital displays (C57/58)

The configuration blocks C57 and C58 are used to fix the number of decimal places displayed to zero, one or two. This configuration can be carried out separately for the upper and the lower display field.

The configuration block C58 can only be selected for cascade control or limiting control and defines the decimal point for the follower or the primary controller.

The different configuration options can be found in the configuration table in Appendix A .

Appendix A Configuration table

C1	Control modes	FSP	FO1	FO2	RC1	RC2	CA1	CA2	SY	Com.
C1-1	Fixed set point control	FSP	■							
C1-4	Follow-up control	FO1		■						
C1-5	Follow-up control with int./ext. changeover	FO2			■					
C1-7	Ratio control	RC1				■				
C1-8	Ratio control with int./ext. changeover	RC2					■			
C1-10	Cascade control with internal reference variable	CA1						■		1)
C1-11	Cascade control with external reference variable	CA2							■	1)
C1-13	Synchro control	SY								■

C2	Feedforward control	FSP	FO1	FO2	RC1	RC2	CA1	CA2	SY	Com.2)
C2-1	No	■	■	■	■	■	■	■	■	
C2-2	Controller input	■	■	■	■	■	■	■	■	3)
C2-3	Controller output	■	■	■	■	■	■	■	■	4)
C2-4	Controller input and controller output	■								
C2-5	Reference variable	■	■	■			■	■		3)
C2-6	Reference variable and controller output	■								
C2-7	Controller input						■	■		4)
C2-8	Reference variable						■	■		4),5)
C2-9	Controller input	■	■	■	■	■	■	■	■	3)
C2-10	Controller output						■	■		3)
C2-11	Controller output				■					

-
- 1) When selecting C1-10 or C1-11 together with C33-8 to C33-15, the cascade control mode is converted to limiting control mode. The master controller will then be the limiting controller and the follower controller becomes the primary controller.
- 2) Feedforward control using the Z input is not possible if C33-2 to C33-7 is set.
- 3) Master or limiting controller in the cascade control mode.
- 4) Follower or primary controller in the cascade control mode.
- 5) Configuration number is skipped if C33<8.

C3	Calculation specification for feedforward control		FSP	FO1	FO2	RC1	RC2	CA1	CA2	SY	Com. 1)
	Mathematical sign of arithmetic element	Disturbance variable									
C3-1	+	+	■	■	■	■	■	■	■	■	
C3-2	-	+	■	■	■	■	■	■	■	■	
C3-3	+	-	■	■	■	■	■	■	■	■	2)
C3-4	-	-	■	■	■	■	■	■	■	■	2)
C3-5	+	x	■	■	■	■	■	■	■	■	2)
C3-6	-	x	■	■	■	■	■	■	■	■	2)
C3-7	+	/	■	■	■	■	■	■	■	■	2)
C3-8	-	/	■	■	■	■	■	■	■	■	2)
C3-9	+ or -	+	■	■	■	■	■	■	■	■	
C3-10	+ or -	-	■	■	■	■	■	■	■	■	
C3-11	+ or -	x	■	■	■	■	■	■	■	■	
C3-12	+ or -	/	■	■	■	■	■	■	■	■	

1) Configuration block is skipped if C2-1 is set.

2) Configuration switch is skipped if C2-2, C2-5 or C2-8 is set.

C4	Configuration of digital display		FSP	FO1	FO2	RC1	RC2	CA1	CA2	SY	Com.
	Upper display field	Lower display field									
C4-1	Reference variable	Actual value	■	■	■			■	■	■	1)
	Set point ratio	Actual value ratio				■	■				
C4-2	Reference variable	Controlled variable	■	■	■			■	■	■	1)
C4-3	Reference variable W _{EX}	Actual value		■	■	■	■			■	
	Reference variable	Actual value						■	■		2)
C4-4	Reference variable W _{EX}	Controlled variable		■	■	■	■			■	
	Reference variable	Controlled variable						■	■		2)
C4-5	Reference variable	Actual value, standardized	■	■	■						
	Reference variable W _{EX}	Actual value							■		3)
C4-6	Reference variable W _{EX}	Controlled variable							■		3)
	Set point ratio	Reference variable W _{EX}				■	■				
	Reference variable W _{EX}	Controlled variable							■		4)
C4-7	Reference variable before reference variable ramp	Actual value	■	■	■			■	■	■	3)
	Set point ratio before set point ratio ramp	Actual value ratio				■	■				
	Reference variable	Actual value						■	■		4)

-
- 1) Display can be switched to follower controller in the cascade control mode via key [B].
2) Display can be switched to follower controller in the cascade control mode via key [B] or [F].
3) Master or limiting controller in the cascade control mode.
4) Follower or primary controller in the cascade control mode.

C5	Configuration of controller outputs			FSP	FO1	FO2	RC1	RC2	CA1	CA2	SY	Com.
	Y ₁	Y ₂	ΔY									
C5-1	No	No	No	■	■	■	■	■	■	■	■	
C5-2	Continuous	No	No	■	■	■	■	■	■	■	■	
C5-3	Continuous	Continuous	No	■	■	■	■	■	■	■	■	
C5-4	Continuous	Continuous	On/off without position feedback	■	■	■	■	■	■	■	■	
C5-5	Continuous	Continuous	On/off with PP converter	■	■	■	■	■	■	■	■	
C5-6	Continuous	Continuous	Three-step with external position feedback	■	■	■	■	■	■	■	■	
C5-7	Continuous	Continuous	Three-step with internal position feedback	■	■	■	■	■	■	■	■	
C5-8	Continuous	Continuous	Three-step with external position feedback and PP converter	■	■	■	■	■	■	■	■	
C5-9	No	Continuous	On/off without position feedback	■	■	■	■	■	■	■	■	
C5-10	No	Continuous	On/off with PP converter	■	■	■	■	■	■	■	■	
C5-11	No	Continuous	Three-step with external position feedback	■	■	■	■	■	■	■	■	
C5-12	No	Continuous	Three-step with internal position feedback	■	■	■	■	■	■	■	■	
C5-13	No	Continuous	Three-step with external position feedback and PP converter	■	■	■	■	■	■	■	■	

C6	Inversion of error			FSP	FO1	FO2	RC1	RC2	CA1	CA2	SY	Com.
	In cascade control mode											
		Master or limiting controller	Follower or primary controller									
C6-1	No	No	No	■	■	■	■	■	■	■	■	
C6-2	Yes	No	Yes	■	■	■	■	■	■	■	■	
C6-3		Yes	No						■	■		
C6-4		Yes	Yes						■	■		

C7	Function generation			FSP	FO1	FO2	RC1	RC2	CA1	CA2	SY	Com.
C7-1	No			■	■	■	■	■	■	■	■	
C7-2	X input			■	■	■	■	■	■	■	■	
C7-3	W _{EX} input			■	■	■	■	■	■	■	■	
C7-4	Z input			■	■	■	■	■	■	■	■	
C7-5	Y _{ACTUAT} input			■	■	■	■	■	■	■	■	
C7-6	Y ₁ output			■	■	■	■	■	■	■	■	
C7-7	Y ₂ output			■	■	■	■	■	■	■	■	
C7-8	A _o output			■	■	■	■	■	■	■	■	
C7-9	Reference variable			■	■	■	■	■	■	■	■	

C8	Linking of input variables	FSP	FO1	FO2	RC1	RC2	CA1	CA2	SY	Com. 1)
C8-1	Addition: $X + A$	■	■	■	■	■	■	■	■	2)
C8-2	Subtraction: $X - A$	■	■	■	■	■	■	■	■	2)
C8-3	Multiplication: $X \times A$	■	■	■	■	■	■	■	■	2)
C8-4	Mean value: $(X + A)/2$	■	■	■	■	■	■	■	■	2)
C8-5	Comparison: X , if $X < A$ A , if $X > A$	■	■	■	■	■	■	■	■	2)
C8-6	Comparison: X , if $X > A$ A , if $X < A$	■	■	■	■	■	■	■	■	2)
C8-7	Calculation specification B	■								3), 4)

C9	Root-extraction of input variables	FSP	FO1	FO2	RC1	RC2	CA1	CA2	SY	Com.
C9-1	No	■	■	■	■	■	■	■	■	
C9-2	X input	■	■	■	■	■	■	■	■	
C9-3	W_{EX} input	■	■	■	■	■	■	■	■	
C9-4	X and W_{EX} input	■	■	■	■	■	■	■	■	
C9-5	Z input	■	■	■	■	■	■	■	■	
C9-6	X and Z input	■	■	■	■	■	■	■	■	
C9-7	W_{EX} and Z input	■	■	■	■	■	■	■	■	
C9-8	X, W_{EX} and Z input	■	■	■	■	■	■	■	■	
C9-9	Y_{ACTUAT} input	■	■	■	■	■	■	■	■	
C9-10	X und Y_{ACTUAT} input	■	■	■	■	■	■	■	■	
C9-11	W_{EX} and Y_{ACTUAT} input	■	■	■	■	■	■	■	■	
C9-12	X, W_{EX} and Y_{ACTUAT} input	■	■	■	■	■	■	■	■	
C9-13	Z and Y_{ACTUAT} input	■	■	■	■	■	■	■	■	
C9-14	X, Z and Y_{ACTUAT} input	■	■	■	■	■	■	■	■	
C9-15	W_{EX} , Z and Y_{ACTUAT} input	■	■	■	■	■	■	■	■	
C9-16	X, W_{EX} , Z and Y_{ACTUAT} input	■	■	■	■	■	■	■	■	

1) Configuration block C8 is skipped if C2-11 is set.

2) Value of A results from selected feedforward control, see chapter 4.6.

3) Configuration switch is skipped if C2-2 or C2-4 is set.

4) $B = K_2 + K_1 W_{EX} \cdot W'_{EX} \cdot \frac{K_1 \cdot X' + K_1 Z \cdot Z'}{K_2 X \cdot X' + K_2 Z \cdot Z'}$; see also chapter 4.6.

C10	Assignment of analog inputs to X input	FSP	FO1	FO2	RC1	RC2	CA1	CA2	SY	Com.
C10-1	No	■	■	■	■	■	■	■	■	
C10-2	Analog input 1	■	■	■	■	■	■	■	■	
C10-3	Analog input 2	■	■	■	■	■	■	■	■	
C10-4	Analog input 3	■	■	■	■	■	■	■	■	
C10-5	Analog input 4	■	■	■	■	■	■	■	■	
C10-6	Serial interface	■	■	■	■	■	■	■	■	

C11	Assignment of analog inputs to W_{EX} input	FSP	FO1	FO2	RC1	RC2	CA1	CA2	SY	Com.
C11-1	No	■	■	■	■	■	■	■	■	
C11-2	Analog input 1	■	■	■	■	■	■	■	■	
C11-3	Analog input 2	■	■	■	■	■	■	■	■	
C11-4	Analog input 3	■	■	■	■	■	■	■	■	
C11-5	Analog input 4	■	■	■	■	■	■	■	■	
C11-6	Serial interface	■	■	■	■	■	■	■	■	

C12	Assignment of analog inputs to Z input	FSP	FO1	FO2	RC1	RC2	CA1	CA2	SY	Com.
C12-1	No	■	■	■	■	■	■	■	■	
C12-2	Analog input 1	■	■	■	■	■	■	■	■	
C12-3	Analog input 2	■	■	■	■	■	■	■	■	
C12-4	Analog input 3	■	■	■	■	■	■	■	■	
C12-5	Analog input 4	■	■	■	■	■	■	■	■	
C12-6	Serial interface	■	■	■	■	■	■	■	■	

C13	Assignment of analog inputs to Y_{ACTUAT} input	FSP	FO1	FO2	RC1	RC2	CA1	CA2	SY	Com.
C13-1	No	■	■	■	■	■	■	■	■	
C13-2	Analog input 1	■	■	■	■	■	■	■	■	
C13-3	Analog input 2	■	■	■	■	■	■	■	■	
C13-4	Analog input 3	■	■	■	■	■	■	■	■	
C13-5	Analog input 4	■	■	■	■	■	■	■	■	
C13-6	Serial interface	■	■	■	■	■	■	■	■	

C14	Adjustment and calibration of analog inputs and analog outputs	FSP	FO1	FO2	RC1	RC2	CA1	CA2	SY	Com.
C14-1	No	■	■	■	■	■	■	■	■	
C14-2	Yes	■	■	■	■	■	■	■	■	

C15	Monitoring of measuring range	FSP	FO1	FO2	RC1	RC2	CA1	CA2	SY	Com.
C15-1	No	■	■	■	■	■	■	■	■	
C15-2	X input	■	■	■	■	■	■	■	■	
C15-3	WEX input	■	■	■	■	■	■	■	■	
C15-4	X and WEX input	■	■	■	■	■	■	■	■	
C15-5	Z input	■	■	■	■	■	■	■	■	
C15-6	X and Z input	■	■	■	■	■	■	■	■	
C15-7	WEX and Z input	■	■	■	■	■	■	■	■	
C15-8	X, WEX and Z input	■	■	■	■	■	■	■	■	
C15-9	YACTUAT input	■	■	■	■	■	■	■	■	
C15-10	X and YACTUAT input	■	■	■	■	■	■	■	■	
C15-11	WEX and YACTUAT input	■	■	■	■	■	■	■	■	
C15-12	X, WEX and YACTUAT input	■	■	■	■	■	■	■	■	
C15-13	Z and YACTUAT input	■	■	■	■	■	■	■	■	
C15-14	X,Z and YACTUAT input	■	■	■	■	■	■	■	■	
C15-15	WEX, Z and YACTUAT input	■	■	■	■	■	■	■	■	
C15-16	X, WEX, Z and YACTUAT input	■	■	■	■	■	■	■	■	

C16	Reference variable ramp	FSP	FO1	FO2	RC1	RC2	CA1	CA2	SY	Com. ¹⁾
C16-1	No	■	■	■	■	■	■	■	■	
C16-2	With starting condition	■	■	■	■	■	■	■	■	2)
C16-3	Without starting condition	■	■	■	■	■	■	■	■	2)
C16-4	Continuous increase or decrease via binary input (bi)	■	■	■	■	■	■	■	■	2)
C16-5	Instantaneous increase or decrease via bi	■	■	■	■	■	■	■	■	2)

1) Master or limiting controller in the cascade control mode.

2) In cascade control mode, the reference variable of the master or limiting controller is used.

C17	Configuration of binary input bi 1	FSP	FO1	FO2	RC1	RC2	CA1	CA2	SY	Com.
C17-1	No	■	■	■	■	■	■	■	■	
C17-2	External system-ready signal	■	■	■	■	■	■	■	■	1)
C17-3	Initialization of reference variable ramp	■	■	■	■	■	■	■	■	1)
C17-4	Initialization of output ramp	■	■	■	■	■	■	■	■	2)
C17-5	Initialization of output value Y ₁ K ₁ for controller output Y ₁	■	■	■	■	■	■	■	■	2), 3)
	Initialization of output value Y ₁ K ₃ (PID), only in combination with C18-5	■	■	■	■	■	■	■	■	2)
C17-6	Initialization of output value Y ₁ K ₁ for controller output Y ₁ (PID), only in the automatic mode	■	■	■	■	■	■	■	■	2), 4)
C17-7	Locking of output signals Y ₁ and Y ₂	■	■	■	■	■	■	■	■	2)
C17-8	Increase or decrease in actual value	■	■	■	■	■	■	■	■	1)
C17-9	Reference variable changeover from W _{EX} to W _{IN}			■		■				5)
	Changeover to follower controller mode						■	■		6)
	Changeover of display to primary controller						■	■		7)
C17-10	Changeover to manual mode	■	■	■	■	■	■	■	■	8)
C17-11	Changeover to position correction	■	■	■	■	■	■	■	■	
C17-12	Locking of manual mode when measuring range monitoring function is active	■	■	■	■	■	■	■	■	
C17-13	Changeover of digital displays to definition of C4-1	■	■	■	■	■	■	■	■	
C17-14	Activation of limit relay G1	■	■	■	■	■	■	■	■	
C17-15	Initialization of change of control action	■	■	■	■	■	■	■	■	

1) Master or limiting controller in the cascade control mode.

2) Follower or primary controller in the cascade control mode.

3) Priority over C33, C35, C37, C43 and output value Y₁K₃.

4) Configuration switch is skipped if C18-6 is set; priority over C33, C35, C37, C43.

5) Key [B] is locked.

6) In cascade control mode, key [B] is locked.

7) In limiting control mode, key [B] is locked.

8) Priority over C37.

C18	Configuration of binary input bi 2	FSP	FO1	FO2	RC1	RC2	CA1	CA2	SY	Com.
C18-1	No	■	■	■	■	■	■	■	■	
C18-2	External system-ready signal	■	■	■	■	■	■	■	■	1)
C18-3	Initialization of reference variable ramp	■	■	■	■	■	■	■	■	1)
C18-4	Initialization of output ramp	■	■	■	■	■	■	■	■	2)
C18-5	Initialization of output value $Y_2 K_1$ for controller output Y_2	■	■	■	■	■	■	■	■	2)
	Initialization of output value $Y_1 K_3$ (PID), only in combination with C17-5	■	■	■	■	■	■	■	■	2)
C18-6	Initialization of output value $Y_2 K_1$ for controller output Y_2 (PID), only in the automatic mode	■	■	■	■	■	■	■	■	2), 3)
C18-7	Locking of output signals Y_1 and Y_2	■	■	■	■	■	■	■	■	2)
C18-8	Increase or decrease in actual value	■	■	■	■	■	■	■	■	1)
C18-9	Reference variable changeover from W_{EX} to W_{IN}			■		■				4)
	Changeover to follower controller mode						■	■		5)
	Changeover of display to primary controller						■	■		6)
C18-10	Changeover to manual mode	■	■	■	■	■	■	■	■	7)
C18-11	Changeover to position correction	■	■	■	■	■	■	■	■	
C18-12	Locking of manual mode when measuring range monitoring function is active	■	■	■	■	■	■	■	■	
C18-13	Changeover of digital displays to definition of C4-1	■	■	■	■	■	■	■	■	
C18-14	Activation of limit relay G2	■	■	■	■	■	■	■	■	
C18-15	Initialization of change of control action	■	■	■	■	■	■	■	■	

1) Master or limiting controller in the cascade control mode.

2) Follower or primary controller in the cascade control mode.

3) Configuration switch is skipped if C17-6 is set; priority over C33, C35, C37, C43.

4) Key [B] is locked.

5) In cascade control mode, key [B] is locked.

6) In limiting control mode, key [B] is locked.

7) Priority over C37.

C19	Configuration of binary input bi 3	FSP	FO1	FO2	RC1	RC2	CA1	CA2	SY	Com.
C19-1	No	■	■	■	■	■	■	■	■	
C19-2	External system-ready signal	■	■	■	■	■	■	■	■	
C19-3	Initialization of reference variable ramp	■	■	■	■	■	■	■	■	1)
C19-4	Initialization of output ramp	■	■	■	■	■	■	■	■	2)
C19-5	Reference variable changeover from W_{IN} to W_{EX}						■	■		3)
C19-6	Initialization of output value Y1 K4 for master or limiting controller (PID)						■	■		4)
C19-7	Locking of output signals Y_1 and Y_2	■	■	■	■	■	■	■	■	2)
C19-8	Increase or decrease in actual value	■	■	■	■	■	■	■	■	4)
C19-9	Reference variable changeover from W_{EX} to W_{IN}			■		■				5)
	Changeover to follower controller mode						■	■		5)
	Changeover of display to primary controller						■	■		5)
C19-10	Changeover to manual mode	■	■	■	■	■	■	■	■	6)
C19-11	Changeover to position correction	■	■	■	■	■	■	■	■	
C19-12	Locking of manual mode when measuring range monitoring function is active	■	■	■	■	■	■	■	■	
C19-13	Changeover of digital displays to definition of C4-1	■	■	■	■	■	■	■	■	
C19-14	Locking of operator keys and/or protection against unauthorized modification of configuration and parameter data	■	■	■	■	■	■	■	■	
C19-15	Initialization of change of control action	■	■	■	■	■	■	■	■	

-
- 1) Master or limiting controller in the cascade control mode.
 - 2) Follower or primary controller in the cascade control mode.
 - 3) Only selectable for limiting control.
 - 4) Master or limiting controller in the cascade control mode.
 - 5) Key [B] is locked.
 - 6) Priority over C37.

C20	Limitation of reference variable or reciprocal set point/actual value ratio	FSP	FO1	FO2	RC1	RC2	CA1	CA2	SY	Com.
C20-1	No	■	■	■	■	■	■	■	■	
C20-2	Limitation of reference variable	■	■	■					■	
C20-3	Reciprocal set point or actual value ratio				■	■				

C21	Reference variable upon failure of external system	FSP	FO1	FO2	RC1	RC2	CA1	CA2	SY	Com.1)
C21-1	Last value of reference variable	■	■	■			■	■	■	
	Last set point ratio				■	■				
C21-2	Safety set point W _S	■	■	■			■	■	■	
	Set point ratio W _S				■	■				
C21-3	Last actual value	■	■	■			■	■	■	
	Last actual value ratio				■	■				
C21-4	Safety set point W _S	■		■			■			
	Set point ratio W _S				■	■				

1) Master or limiting controller in the cascade control mode.

2) Same function as C21-2, however, key [B] is switched to W_{IN} and W_S is copied to W_{IN}.

C22	Assignment of internal reference variable or set point ratio	FSP	FO1	FO2	RC1	RC2	CA1	CA2	SY	Com.
C22-1	No	■		■	■	■	■	■		
C22-2	Correction to external reference variable or to external set point ratio			■		■				
C22-3	Internal reference variable or internal set point ratio only adjustable in the parameter level	■		■	■	■	■			1)
C22-4	Addition to external reference variable ($W_{EX} + W_{IN}$)			■						
C22-5	Subtraction from external reference variable ($W_{EX} - W_{IN}$)			■						
C22-6	Subtraction from external reference variable ($W_{EX} - W_{IN}$)			■						
C22-7	Comparison: W_{IN} , if $W_{IN} > W_{EX}$ or W_{EX} , if $W_{IN} < W_{EX}$			■						
C22-8	Comparison: W_{IN} , if $W_{IN} < W_{EX}$ or W_{EX} , if $W_{IN} > W_{EX}$			■						
C22-9	Addition of Y_{MA} to W_{INFO} ($Y_{MA} + W_{INFO}$)						■	■		2), 3)
C22-10	Subtraction of Y_{MA} from W_{INFO} ($Y_{MA} - W_{INFO}$)						■	■		2), 3)
C22-11	Subtraction of W_{INFO} from Y_{MA} ($W_{INFO} - Y_{MA}$)						■	■		2), 3)
C22-12	Comparison: W_{INFO} , if $W_{INFO} > Y_{MA}$ or Y_{MA} , if $W_{INFO} < Y_{MA}$						■	■		2), 3)
C22-13	Comparison: W_{INFO} , if $W_{INFO} < Y_{MA}$ or Y_{MA} , if $W_{INFO} > Y_{MA}$						■	■		2), 3)

1) Master or limiting controller in the cascade control mode.

2) Follower controller in the cascade control mode.

3) It is skipped if $C33 > 1$.

C23	X-tracking	FSP	FO1	FO2	RC1	RC2	CA1	CA2	SY	2)
C23-1	No	■		■	■	■	■			3)
C23-2	Yes	■		■	■	■	■			

C24	Dynamic behavior of controller outputs	FSP	FO1	FO2	RC1	RC2	CA1	CA2	SY	Com. 1)
C24-1	P	■	■	■	■	■	■	■	■	
C24-2	PI	■	■	■	■	■	■	■	■	
C24-3	PD	■	■	■	■	■	■	■	■	
C24-4	PID	■	■	■	■	■	■	■	■	
C24-5	PPI	■	■	■	■	■	■	■	■	
C24-6	Integral	■	■	■	■	■	■	■	■	
	With adaptation of I-action component									
C24-7	PI	■	■	■	■	■	■	■	■	
C24-8	PID	■	■	■	■	■	■	■	■	
C24-10	Integral	■	■	■	■	■	■	■	■	

C25	Dynamic behavior of controller output of follower or primary controller	FSP	FO1	FO2	RC1	RC2	CA1	CA2	SY	Com. 2)
C25-1	P						■	■		
C25-2	PI						■	■		
C25-3	PD						■	■		
C25-4	PID						■	■		
C25-6	Integral						■	■		
	With adaptation of I-action component									
C25-7	PI						■	■		
C25-8	PID						■	■		
C25-10	Integral						■	■		

1) Follower or primary controller in the cascade control mode.

2) Master or limiting controller in the cascade control mode.

3) Configuration switch is selected if $C16 \geq 2$ (reference variable ramp), $C33 \geq 8$ (internal output signal limitation), $C7-9$ or $C2-5/6$.

C26	Input variable for D element		FSP	FO1	FO2	RC1	RC2	CA1	CA2	SY	Com. 1)
C26-1	Error		■	■	■	■	■			■	
C26-2	Actual value		■	■	■	■	■			■	
C26-3	Controlled variable		■	■	■	■	■			■	
	Master or limiting controller	Follower or primary controller									
C26-1	Error	Error						■	■		
C26-2	Error	Actual value						■	■		
C26-3	Error	Controlled variable						■	■		
C26-4	Actual value	Error						■	■		
C26-5	Actual value	Actual value						■	■		
C26-6	Actual value	Controlled variable						■	■		
C26-7	Controlled variable	Error						■	■		
C26-8	Controlled variable	Actual value						■	■		
C26-9	Controlled variable	Controlled variable						■	■		

1) It is skipped if no D-action component has been selected for control, i.e. C24/C25-1/2/5/6/7/10.

C27	Filtering of input variables and error (Pt1 behavior)	FSP	FO1	FO2	RC1	RC2	CA1	CA2	SY	Com.
C27-1	No	■	■	■	■	■	■	■	■	
C27-2	X _d	■	■	■	■	■	■	■	■	1)
C27-3	X input	■	■	■	■	■	■	■	■	
C27-4	X _d und X input	■	■	■	■	■	■	■	■	
C27-5	Z input	■	■	■	■	■	■	■	■	
C27-6	X _d and Z input	■	■	■	■	■	■	■	■	
C27-7	X and Z input	■	■	■	■	■	■	■	■	
C27-8	X _d , X and Z input	■	■	■	■	■	■	■	■	
C27-9	WEX input	■	■	■	■	■	■	■	■	
C27-10	X _d and WEX input	■	■	■	■	■	■	■	■	
C27-11	WEX and X input	■	■	■	■	■	■	■	■	
C27-12	X _d , WEX and X input	■	■	■	■	■	■	■	■	
C27-13	WEX and Z input	■	■	■	■	■	■	■	■	
C27-14	X _d , WEX and Z input	■	■	■	■	■	■	■	■	
C27-15	WEX, X and Z input	■	■	■	■	■	■	■	■	
C27-16	X _d , WEX, X and Z input	■	■	■	■	■	■	■	■	

C28	Operating point adjustment in manual mode	FSP	FO1	FO2	RC1	RC2	CA1	CA2	SY	Com.2)
C28-1	No	■	■	■	■	■	■	■	■	3)
C28-2	Yes	■	■	■	■	■	■	■	■	

- 1) Master or limiting controller in the cascade control mode.
2) Follower or primary controller in the cascade control mode.
3) Configuration switch is set if C24-2 or C24>3.

C29	Change of control action	FSP	FO1	FO2	RC1	RC2	CA1	CA2	SY	Com.
C29-1	No	■	■	■	■	■	■	■	■	
C29-2	P(D)/PI(D) control action	■	■	■	■	■			■	
	P(D)/PI(D) control action on follower or primary controller						■	■		
C29-3	P(D)/PI(D) control action on master or limiting controller						■	■		
C29-4	P(D)/PI(D) control action on master or limiting controller as well as on follower or primary controller						■	■		
C29-5	Y ₀ /PI(D) control action with operating point adjustment via K ₆	■	■	■	■	■			■	
	Y ₀ /PI(D) control action with operating point adjustment via K ₆ on follower or primary controller						■	■		
C29-6	Y ₀ /PI(D) control action with operating point adjustment via W _{EX}	■								1)
	Y ₀ /PI(D) control action with operating point adjustment via W _{EX} on follower or primary controller						■			1)
C29-7	Y ₀ /PI(D) control action with operating point adjustment via Z	■	■	■	■				■	2)
C29-8	Y _{MAX} /Y ₀ /PI(D) control action with operating point adjustment via K ₆	■	■	■	■	■			■	
	Y _{MAX} /Y ₀ /PI(D) control action with operating point adjustment via K ₆ on follower or primary controller						■	■		
C29-9	Y _{MAX} /Y ₀ /PI(D) control action with operating point adjustment via W _{EX}	■								1)
	Y _{MAX} /Y ₀ /PI(D) control action with operating point adjustment via W _{EX} on follower or primary controller						■			1)
C29-10	Y _{MAX} /Y ₀ /PI(D) control action with operating point adjustment via Z	■	■	■	■				■	2)

1) It is skipped if C11-2.

2) It is skipped if C12-2.

C30	Operating point adjustment via reference variable	FSP	FO1	FO2	RC1	RC2	CA1	CA2	SY	Com. 1)
C30-1	No	■	■	■					■	2)
	No, on master or limiting controller						■	■		
C30-2	Yes	■	■	■					■	
	Yes, on master or limiting controller						■	■		

C31	Signal ranges			FSP	FO1	FO2	RC1	RC2	CA1	CA2	SY	Com.
	Y1	Y2	Ao1									
C31-1	0 to 20 mA 0 to 10 V	0 to 20 mA 0 to 10 V	0 to 20 mA 0 to 10 V	■	■	■	■	■	■	■	■	3)
C31-2	4 to 20 mA 2 to 10 V	4 to 20 mA 2 to 10 V	0 to 20 mA 0 to 10 V	■	■	■	■	■	■	■	■	
C31-3	0 to 20 mA 0 to 10 V	4 to 20 mA 2 to 10 V	0 to 20 mA 0 to 10 V	■	■	■	■	■	■	■	■	
C31-4	4 to 20 mA 2 to 10 V	0 to 20 mA 0 to 10 V	0 to 20 mA 0 to 10 V	■	■	■	■	■	■	■	■	
C31-5	0 to 20 mA 0 to 10 V	0 to 20 mA 0 to 10 V	4 to 20 mA 2 to 10 V	■	■	■	■	■	■	■	■	
C31-6	4 to 20 mA 2 to 10 V	4 to 20 mA 2 to 10 V	4 to 20 mA 2 to 10 V	■	■	■	■	■	■	■	■	
C31-7	0 to 20 mA 0 to 10 V	4 to 20 mA 2 to 10 V	4 to 20 mA 2 to 10 V	■	■	■	■	■	■	■	■	
C31-8	4 to 20 mA 2 to 10 V	0 to 20 mA 0 to 10 V	4 to 20 mA 2 to 10 V	■	■	■	■	■	■	■	■	

1) Master or limiting controller in the cascade control mode.

2) This is set if $C16 \geq 2$ or dynamic behavior with I-action component has been selected, i. e. C24/C25-2/4/5/6/7/8/10.

3) Follower or primary controller in the cascade control mode.

C32	Operating direction of output variables			FSP	FO1	FO2	RC1	RC2	CA1	CA2	SY	Com. 1)
	Y1	Y2										
C32-1	increasing	decreasing		■	■	■	■	■	■	■	■	
C32-2	decreasing	decreasing		■	■	■	■	■	■	■	■	
C32-3	increasing	increasing		■	■	■	■	■	■	■	■	
C32-4	decreasing	increasing		■	■	■	■	■	■	■	■	

C33	Output signal limitation			FSP	FO1	FO2	RC1	RC2	CA1	CA2	SY	Com. 3)
	Y1	Y2	YPID									
C33-1	No	No	No	■	■	■	■		■	■	■	4)
	Externally controlled											
C33-2	Max.	No	No	■	■	■	■				■	
C33-3	Min.	No	No	■	■	■	■				■	
C33-4	No	Max.	No	■	■	■	■				■	
C33-5	No	Min.	No	■	■	■	■				■	
C33-6	No	No	Max.	■	■	■	■				■	
C33-7	No	No	Min.	■	■	■	■				■	
	Internally controlled											
C33-8	Max.	No	No						■	■		3)
C33-9	Min.	No	No						■	■		3)
C33-10	No	Max.	No						■	■		3)
C33-11	No	Min.	No						■	■		3)
C33-12	No	No	Max.						■	■		3)
C33-13	No	No	Min.						■	■		3)
C33-14	Selection of minimum output variable								■	■		3)
C33-15	Selection of maximum output variable								■	■		3)

1) Follower or primary controller in the cascade control mode.

2) Limitation is cancelled if safety output value Y1K1, Y2K1, Y1K3 or Y1K4 has been activated via binary input.

3) Cascade control is converted to limiting control. Now, the master controller becomes the limiting controller, and the follower controller will be the primary controller.

4) It is set if C22≥9.

C34	Output ramp or limitation of the rate of output changes	FSP	FO1	FO2	RC1	RC2	CA1	CA2	SY	Com.
C34-1	No	■	■	■	■	■	■	■	■	1)
C34-2	Increasing output ramp, starts when safety mode is cancelled	■	■	■	■	■	■	■	■	2)
C34-3	Decreasing output ramp, starts when safety mode is cancelled	■	■	■	■	■	■	■	■	2)
C34-4	Increasing output ramp, start is released via binary input	■	■	■	■	■	■	■	■	3)
C34-5	Decreasing output ramp, start is released via binary input	■	■	■	■	■	■	■	■	4)
C34-6	Limitation of rate of output changes for increasing output variable	■	■	■	■	■	■	■	■	5)
C34-7	Limitation of rate of output changes for decreasing output variable	■	■	■	■	■	■	■	■	5)
C34-8	Limitation of rate of output changes for increasing and decreasing output variable	■	■	■	■	■	■	■	■	5)
C34-9	Increasing output ramp, master or limiting controller with same starting condition as C34-2						■	■		2)
C34-10	Decreasing output ramp, master or limiting controller with same starting condition as C34-3						■	■		2)
C34-11	Increasing output ramp, master or limiting controller with same starting condition as for C34-4						■	■		3)
C34-12	Decreasing output ramp, master or limiting controller with same starting condition as C34-5						■	■		3)
C34-13	Limitation of rate of output changes for increasing output variable of master or limiting controller						■	■		5)
C34-14	Limitation of rate of output changes for decreasing output variable of master or limiting controller						■	■		5)
C34-15	Limitation of rate of output changes for increasing and decreasing output variable of master or limiting controller						■	■		5)

1) It is set if C33-14/15.

2) Start at safety output value Y_1K_1 or Y_2K_1 or Y_1K_4 .3) Start at output value $Y_1 \neq$ via binary input.4) Start at output value $Y_1 \neq$ via binary input.

5) Function is switched off via bi 1, bi 2 or bi 3.

C35	Output signal limitation			FSP	FO1	FO2	RC1	RC2	CA1	CA2	SY	Com. 1)
	Y1	Y2	YPID									
C35-1	No	No	No	■	■	■	■	■	■	■	■	
C35-2	Min./Max.	No	No	■	■	■	■	■	■	■	■	
C35-3	No	Min./Max.	No	■	■	■	■	■	■	■	■	
C35-4	Min./Max.	Min./Max.	No	■	■	■	■	■	■	■	■	
C35-5	No	No	Min./Max.	■	■	■	■	■	■	■	■	

C36	Output signal limitation turned off in manual mode			FSP	FO1	FO2	RC1	RC2	CA1	CA2	SY	Com.
C36-1	No			■	■	■	■	■	■	■	■	
C36-2	Yes			■	■	■	■	■	■	■	■	

C37	Changeover to manual mode when signals are outside the measuring range			FSP	FO1	FO2	RC1	RC2	CA1	CA2	SY	Com.
C37-1	No			■	■	■	■	■	■	■	■	
C37-2	Yes, with last output value			■	■	■	■	■	■	■	■	
C37-3	Yes, with output value Y ₁ K ₁ for Y ₁ output			■	■	■	■	■	■	■	■	
C37-4	Yes, with output value Y ₂ K ₁ for Y ₂ output			■	■	■	■	■	■	■	■	

C38	Assignment of output variable displays		FSP	FO1	FO2	RC1	RC2	CA1	CA2	SY	Com. 2)
	Bar graph	Digital display									
C38-1	No	No	■	■	■	■	■	■	■	■	
C38-2	YPID	YPID	■	■	■	■	■	■	■	■	
C38-3	YACTUAT input	YPID	■	■	■	■	■	■	■	■	
C38-4	YPID	YACTUAT input	■	■	■	■	■	■	■	■	
C38-5	Y1	Y1	■	■	■	■	■	■	■	■	
C38-6	Y2	Y2	■	■	■	■	■	■	■	■	
C38-7	Y1	Y2	■	■	■	■	■	■	■	■	
C38-8	Y2	Y1	■	■	■	■	■	■	■	■	

- 1) Follower controller in the cascade control mode. Limitation is cancelled if output value Y₁K₁ or Y₂K₁ or Y₁K₃ has been activated via binary input.
- 2) Follower controller in the cascade control mode.

C39	Inversion of output variable display	FSP	FO1	FO2	RC1	RC2	CA1	CA2	SY	Com.1)
C39-1	No	■	■	■	■	■	■	■	■	
C39-2	Yes	■	■	■	■	■	■	■	■	

C40	Assignment of limit relay G1		FSP	FO1	FO2	RC1	RC2	CA1	CA2	SY	Com.2)
	Maximum contact	Minimum contact									3)
C40-1	No		■	■	■	■	■	■	■	■	4)
C40-2	To X input		■	■	■	■	■	■	■	■	
C40-3	To WEX input		■	■	■	■	■	■	■	■	
C40-4	To Z input		■	■	■	■	■			■	
C40-5	To positive error		■	■	■			■	■	■	
	To actual value ratio					■	■				5)
C40-6		To actual value ratio				■	■				6)
C40-7	To error (amount)		■	■	■	■	■	■	■	■	
C40-8	To Y1 output		■	■	■	■	■			■	
C40-9	To Y2 output		■	■	■	■	■			■	
C40-10	To YACTUAT input		■	■	■	■	■			■	
C40-11		To X input	■	■	■	■	■	■	■	■	
C40-12		To WEX input	■	■	■	■	■	■	■	■	
C40-13		To Z input	■	■	■	■	■			■	
C40-14		To Y1 output	■	■	■	■	■			■	
C40-15		To Y2 output	■	■	■	■	■			■	
C40-16		To YACTUAT input	■	■	■	■	■			■	

1) Follower controller in the cascade control mode.

2) Master or limiting controller in the cascade control mode.

3) Maximum contact: activation of limit relay if adjusted limit value is exceeded.
Minimum contact: activation of limit relay if adjusted limit value is not reached.

4) Configuration switch is set if C17-14.

5) Activation of limit relay if adjusted limit value is exceeded.

6) Activation of limit relay if adjusted limit value is not reached.

C41	Assignment of limit relay G 2		FSP	FO1	FO2	RC1	RC2	CA1	CA2	SY	Com. 1)
	Maximum contact	Minimum contact									2)
C41-1	No		■	■	■	■	■	■	■	■	3)
C41-2	To X input		■	■	■	■	■			■	
C41-3	To WEX input		■	■	■	■	■			■	
C41-4	To Z input		■	■	■	■	■	■	■	■	
C41-5	To positive error		■	■	■			■	■	■	
	To differential ratio					■	■				4)
C41-7	To error (amount)		■	■	■	■	■	■	■	■	
C41-8	To Y1 output		■	■	■	■	■	■	■	■	
C41-9	To Y2 output		■	■	■	■	■	■	■	■	
C41-10	To YACTUAT input		■	■	■	■	■	■	■	■	
C41-11		To X input	■	■	■	■	■			■	
C41-12		To WEX input	■	■	■	■	■			■	
C41-13		To Z input	■	■	■	■	■	■	■	■	
C41-14		To Y1 output	■	■	■	■	■	■	■	■	
C41-15		To Y2 output	■	■	■	■	■	■	■	■	
C41-16		To YACTUAT input	■	■	■	■	■	■	■	■	

C42	Display of closed position of control valve		FSP	FO1	FO2	RC1	RC2	CA1	CA2	SY	Com.
	C42-1	No		■	■	■	■	■	■	■	■
C42-2	At 0%		■	■	■	■	■	■	■	■	
C42-3	At 100%		■	■	■	■	■	■	■	■	

1) Follower or primary controller in the cascade control mode.

2) Maximum contact: activation of limit relay if adjusted limit value is exceeded.

Minimum contact: activation of limit relay if adjusted limit value is not reached.

3) Configuration switch is set if C18-14.

4) Differential ratio, activation of limit relay if adjusted limit value is exceeded.

C43	Restart conditions upon power supply failure	FSP	FO1	FO2	RC1	RC2	CA1	CA2	SY	Com. 1)
	Start with:									
C43-1	Automatic mode with internal or external reference variable and with output value Y₁K₁ for Y₁ output	■	■	■	■	■	■	■	■	
C43-2	Automatic mode with internal or external reference variable and with output value Y₂K₁ for Y₂ output	■	■	■	■	■	■	■	■	
C43-3	Automatic mode with safety set point W _S and with output value Y₁K₁ for Y₁ output	■	■	■	■	■	■	■	■	
C43-4	Automatic mode with safety set point W _S and with output value Y₂K₁ for Y₂ output	■	■	■	■	■	■	■	■	
C43-5	Manual mode with output value Y₁K₁ for Y₁ output	■	■	■	■	■	■	■	■	
C43-6	Manual mode with output value Y₂K₁ for Y₂ output	■	■	■	■	■	■	■	■	
C43-7	Same as C43-1, however, restart without acknowledgement	■	■	■	■	■	■	■	■	
C43-8	Same as C43-2, however, restart without acknowledgement	■	■	■	■	■	■	■	■	
C43-9	Automatic mode with internal reference variable W _{IN} and with output value Y₁K₁ for Y₁ output			■		■				
C43-10	Automatic mode with internal reference variable W _{IN} and with output value Y₂K₁ for Y₂ output			■		■				
C43-11	Automatic mode with external reference variable W _{EX} and with output value Y₁K₁ for Y₁ output			■		■				
C43-12	Automatic mode with external reference variable W _{EX} and with output value Y₂K₁ for Y₂ output			■		■				

¹⁾ In case the cascade is interrupted, the process control station starts using the reference variable of the follower controller.

C44	Configuration of binary output bo 1	FSP	FO1	FO2	RC1	RC2	CA1	CA2	SY	Com.
	Status signals	■	■	■	■	■	■	■	■	
C44-1	No	■	■	■	■	■	■	■	■	
C44-2	Controller in automatic mode	■	■	■	■	■	■	■	■	
C44-3	Variables outside the measuring range	■	■	■	■	■	■	■	■	1)
C44-4	Modification of configuration data and/or parameters without operator intervention	■	■	■	■	■	■	■	■	
C44-5	No external system-ready signal	■	■	■	■	■	■	■	■	
C44-6	Transfer switch W _{IN} /W _{EX} on position "W _{IN} "			■		■				
C44-7	Activation via serial interface	■	■	■	■	■	■	■	■	
C44-8	Communication interruption	■	■	■	■	■	■	■	■	
C44-9	Cascade interrupted						■	■		

C45	Configuration of binary output bo 2	FSP	FO1	FO2	RC1	RC2	CA1	CA2	SY	Com.
C45-1 to C45-9 equals C44-1 to C44-9										

C46	Repetition rate of digital displays and of error display	FSP	FO1	FO2	RC1	RC2	CA1	CA2	SY	Com.
C46-1	approx. 0.1 s	■	■	■	■	■	■	■	■	
C46-2	approx. 0.2 s	■	■	■	■	■	■	■	■	
C46-3	approx. 0.5 s	■	■	■	■	■	■	■	■	
C46-4	approx. 1 s	■	■	■	■	■	■	■	■	
C46-5	approx. 5 s	■	■	■	■	■	■	■	■	
C46-6	approx. 10 s	■	■	■	■	■	■	■	■	

1) Configuration switch is skipped if C15-1.

C47	Display range of error	FSP	FO1	FO2	RC1	RC2	CA1	CA2	SY	Com.
C47-1	No	■	■	■	■	■	■	■	■	
C47-2	± 6%	■	■	■	■	■	■	■	■	
C47-3	± 12%	■	■	■	■	■	■	■	■	
C47-4	± 30%	■	■	■	■	■	■	■	■	

C48	Assignment of analog output Ao	FSP	FO1	FO2	RC1	RC2	CA1	CA2	SY	Com.
C48-1	No	■	■	■	■	■	■	■	■	
C48-2	To X input	■	■	■	■	■	■	■	■	
C48-3	To W _{EX} input	■	■	■	■	■	■	■	■	
C48-4	To Z input	■	■	■	■	■	■	■	■	
C48-5	To Y _{ACTUAT} input	■	■	■	■	■	■	■	■	
C48-6	To reference variable	■	■	■			■	■	■	1)
	To set point ratio				■	■				
C48-7	To actual value ratio	■	■	■	■	■	■	■	■	1)
C48-8	To actual value ratio				■	■				
C48-9	To error	■	■	■	■	■	■	■	■	1)
C48-10	To reference variable of follower or primary controller						■	■		
C48-11	To actual value of follower or primary controller						■	■		
C48-12	To error of follower or primary controller						■	■		
C48-13	To controller output of master or limiting controller						■	■		
C48-14	To constant Y _{1K5}	■	■	■	■	■	■	■	■	

C49	Power frequency	FSP	FO1	FO2	RC1	RC2	CA1	CA2	SY	Com.
C49-1	50 Hz or dc voltage	■	■	■	■	■	■	■	■	
C49-2	60 Hz	■	■	■	■	■	■	■	■	

1) Master or limiting controller in the cascade control mode.

C50	Dynamic behavior of PD elements		FSP	FO1	FO2	RC1	RC2	CA1	CA2	SY	Com.
	Input element	Output element									
C50-1	P	P	■	■	■	■	■	■	■	■	
C50-2	D	P	■	■	■	■	■	■	■	■	
C50-3	PD	P	■	■	■	■	■	■	■	■	
C50-4	P	D	■	■	■	■	■	■	■	■	
C50-5	D	D	■	■	■	■	■	■	■	■	
C50-6	PD	D	■	■	■	■	■	■	■	■	
C50-7	P	PD	■	■	■	■	■	■	■	■	
C50-8	D	PD	■	■	■	■	■	■	■	■	
C50-9	PD	PD	■	■	■	■	■	■	■	■	

C51	Adaptation of control parameters		FSP	FO1	FO2	RC1	RC2	CA1	CA2	SY	Com.
	Input element	Output element									
C51-1	No		■	■	■	■	■	■	■	■	
C51-2	Single adaptation		■	■	■	■	■			■	
	Single adaptation of follower controller							■	■		
C51-3	Controlled adaptation via actual value signal		■	■	■	■	■			■	
	Controlled adaptation via actual value signal of follower controller							■	■		1)
C51-4	Controlled adaptation via output value signal		■	■	■	■	■			■	
	Controlled adaptation via output value signal of follower controller							■	■		1)
C51-5	Controlled adaptation via external signal (Y _{ACTUAT})		■	■	■	■	■			■	
	Controlled adaptation via external signal (Y _{ACTUAT}) of follower controller							■	■		1)
C51-6	Controlled adaptation via external signal (Z)		■	■	■	■	■			■	
	Controlled adaptation via external signal (Z) of follower controller							■	■		

1) It is skipped if C52>2.

C52	Adaptation of control parameters of master controller	FSP	FO1	FO2	RC1	RC2	CA1	CA2	SY	Com.
C52-1	No						■	■		
C52-2	Single adaptation						■	■		
C52-3	Controlled adaptation via actual value signal						■	■		1)
C52-4	Controlled adaptation via output value signal						■	■		1)
C52-5	Controlled adaptation via external signal (Y _{ACTUAT})						■	■		1)

C53	Adaptation of measuring range of W_{EX} input to the range of X input	FSP	FO1	FO2	RC1	RC2	CA1	CA2	SY	Com.
C53-1	No		■	■				■		2)
C53-2	Yes		■	■				■		

C54	Input boards	FSP	FO1	FO2	RC1	RC2	CA1	CA2	SY	Com. ³⁾
C54-1	Input board 1 (EK1)	■	■	■	■	■	■	■	■	
C54-2	Input board 2 (EK2)	■	■	■	■	■	■	■	■	4)
C54-3	Input board 3 (EK3)	■	■	■	■	■	■	■	■	5)
C54-4	Input board 4 (EK4)	■	■	■	■	■	■	■	■	

1) It is skipped if C51>2.

2) Master or limiting controller in the cascade control mode.

3) The input board used is indicated on the nameplate.

4) When using a Pt 100 resistance thermometer, you have to enter the measuring range for input 1 by means of GWK₁ \sphericalangle and GWK₁ \sphericalright in the parameter level.

5) When using a Pt 100 resistance thermometer, you have to enter the measuring range for input 1 by means of GWK₁ \sphericalangle and GWK₁ \sphericalright as well as for input 2 by means of GWK₂ \sphericalangle and GWK₂ \sphericalright in the parameter level.

C55	For input board 4: selection of thermocouple	FSP	FO1	FO2	RC1	RC2	CA1	CA2	SY	Com. 1)
C55-1	Type B (Pt30Rh/Pt6/Rh)	■	■	■	■	■	■	■	■	
C55-2	Type E (NiCr/CuNi)	■	■	■	■	■	■	■	■	
C52-3	Type J (Fe/CuNi)	■	■	■	■	■	■	■	■	
C55-4	Type K (NiCr/Ni)	■	■	■	■	■	■	■	■	
C55-5	Type L (Fe/CuNi)	■	■	■	■	■	■	■	■	
C55-6	Type R (Pt13Rh/Pt)	■	■	■	■	■	■	■	■	
C55-7	Type S (Pt10Rh/Pt)	■	■	■	■	■	■	■	■	
C55-8	Type T (Cu/CuNi)	■	■	■	■	■	■	■	■	
C55-9	Type U (Cu/CuNi)	■	■	■	■	■	■	■	■	
C55-10	mV	■	■	■	■	■	■	■	■	

C56	Reset to factory default	FSP	FO1	FO2	RC1	RC2	CA1	CA2	SY	Com.
C56-1	No	■	■	■	■	■	■	■	■	
C56-2	Configuration blocks and parameters	■	■	■	■	■	■	■	■	
C56-3	Configuration blocks	■	■	■	■	■	■	■	■	
C56-4	Parameters	■	■	■	■	■	■	■	■	
C56-5	Zero and span of analog inputs	■	■	■	■	■	■	■	■	
C56-6	Span of analog outputs	■	■	■	■	■	■	■	■	
C56-7	Code numbers	■	■	■	■	■	■	■	■	
C56-8	ID number of controller	■	■	■	■	■	■	■	■	
C56-9	Adaptation parameters	■	■	■	■	■	■	■	■	

1) Configuration block C55 is skipped if C54<4.

C57	Decimal point of digital displays		FSP	FO1	FO2	RC1	RC2	CA1	CA2	SY	Com.1)
	Upper display field	Lower display field									
C57-1	1X . XX	1X . XX	■	■	■	■	■	■	■	■	
C57-2	1XX . X	1XX . X	■	■	■	■	■	■	■	■	
C57-3	1XXX	1XXX	■	■	■	■	■	■	■	■	
C57-4	1X . XX	1XX . X	■	■	■	■	■	■	■	■	
C57-5	1X . XX	1XXX	■	■	■	■	■	■	■	■	
C57-6	1XX . X	1X . XX	■	■	■	■	■	■	■	■	
C57-7	1XX . X	1XXX	■	■	■	■	■	■	■	■	
C57-8	1XXX	1X . XX	■	■	■	■	■	■	■	■	
C57-9	1XXX	1XX . X	■	■	■	■	■	■	■	■	

C58	Decimal point of digital displays of primary or follower controller		FSP	FO1	FO2	RC1	RC2	CA1	CA2	SY	Com.1)
	Upper display field	Lower display field									
C58-1	1X . XX	1X . XX						■	■		
C58-2	1XX . X	1XX . X						■	■		
C58-3	1XXX	1XXX						■	■		
C58-4	1X . XX	1XX . X						■	■		
C58-5	1X . XX	1XXX						■	■		
C58-6	1XX . X	1X . XX						■	■		
C58-7	1XX . X	1XXX						■	■		
C58-8	1XXX	1X . XX						■	■		
C58-9	1XXX	1XX . X						■	■		

1) The display can show a maximum of 1999. X represents the figures 0 to 9.

C59	Locking of operator keys or protection against unauthorized modification of configuration and parameter data	FSP	FO1	FO2	RC1	RC2	CA1	CA2	SY	Com. 1)
C59-1	No	■	■	■	■	■	■	■	■	
C59-2	Locking of operator keys	■	■	■	■	■	■	■	■	
C59-3	Protection against unauthorized modification of configuration and parameter data	■	■	■	■	■	■	■	■	
C59-4	Locking of operator keys and/or protection against unauthorized modification of configuration and parameter data	■	■	■	■	■	■	■	■	

1) Configuration switch C59>1 only selectable if C19-14.

Appendix B Parameter table

PA Parameter set for fixed set point, follow-up, ratio or synchro control

PA1 Parameter set for master controller in the cascade control mode

PA2 Parameter set for follower controller in the cascade control mode

Parameter		Designation	Range	Factory default
Name	Set			
GWG1	PA/PA1	Limit value for limit relay 1	-1999 ... 1999 0.00 ... 19.99	0.0
GWG2	PA/PA2	Limit value for limit relay 2	-1999 ... 1999 0.00 ... 19.99	0.0
GWK ₁ \sphericalangle	PA	Minimum measuring-range value for input of 1	-1999 ... 1999 0.00 ... 19.99	0.0
GWK ₁ \sphericalangle	PA	Maximum measuring-range value for input of 1	-1999 ... 1999 0.00 ... 19.99	200.0
GWK ₂ \sphericalangle	PA	Minimum measuring-range value for input of 2	-1999 ... 1999 0.00 ... 19.99	0.0
GWK ₂ \sphericalangle	PA	Maximum measuring-range value for input of 2	-1999 ... 1999 0.00 ... 19.99	200.0
GWK ₃	PA/PA2	Switching point Change of control action	0.0 ... 110.0 %	0.0 %
GWK ₄	PA/PA2	Switching point Change of control action	0.0 ... 110.0 %	0.0 %
GWK ₅	PA1	Switching point Change of control action	0.0 ... 110.0 %	0.0 %
GWK ₆	PA1	Switching point Change of control action	0.0 ... 110.0 %	0.0 %
K ₁	PA/PA2	Y rate action	-110.0 ... 110.0 %	0.0 %
K ₁	PA1	Y rate action	-110.0 ... 110.0 %	0.0 %
K ₁ \sphericalangle	PA	Input signal point 1 (function generation)	-1999 ... 1999 0.00 ... 19.99	0.0
K ₁ \sphericalangle	PA	Output signal point 1 (function generation)	-1999 ... 1999 0.00 ... 19.99	0.0
K ₁ W _{EX}	PA	Constant	-19.99 ... 19.99	1.00
K ₁ X	PA	Constant	-19.99 ... 19.99	1.00
K ₁ Z	PA	Constant	-19.99 ... 19.99	1.00
K ₂	PA/PA1	Constant for increase/decrease in actual value	-110.0 ... 110.0	0.0
K ₂ \sphericalangle	PA	Input signal point 2 (function generation)	-1999 ... 1999 0.00 ... 19.99	0.0
K ₂ \sphericalangle	PA	Output signal point 2 (function generation)	-1999 ... 1999 0.00 ... 19.99	0.0

Parameter		Designation	Range	Factory default
Name	Set			
K ₂ X	PA	Constant	-19.99 ... 19.99	1.00
K ₂ Z	PA	Constant	-19.99 ... 19.99	1.00
K ₃	PA/PA1	Constant for feedforward control	0.0 ... 110.0 %	0.0 %
K ₃ ↘	PA	Input signal point 3 (function generation)	-1999 ... 1999	0.0
K ₃ ↗	PA	Output signal point 3 (function generation)	-1999 ... 1999 0.00 ... 19.99	0.0
K ₄	PA/PA1	Constant for feedforward control	0.00 ... 19.99	1.00
K ₄ ↘	PA	Input signal point 4 (function generation)	-1999 ... 1999 0.00 ... 19.99	0.0
K ₄ ↗	PA	Output signal point 4 (function generation)	-1999 ... 1999 0.00 ... 19.99	0.0
K ₅	PA	Constant for feedforward control	-110.0 ... 110.0 %	0.0 %
K ₅ ↘	PA	Input signal point 5 (function generation)	-1999 ... 1999 0.00 ... 19.99	0.0
K ₅ ↗	PA	Output signal point 5 (function generation)	-1999 ... 1999 0.00 ... 19.99	0.0
K ₆	PA/PA2	Constant for change of control action	0.0 ... 110.0 %	0.0 %
K ₆ ↘	PA	Input signal point 6 (function generation)	-1999 ... 1999 0.00 ... 19.99	0.0
K ₆ ↗	PA	Output signal point 6 (function generation)	-1999 ... 1999 0.00 ... 19.99	0.0
K ₇	PA/PA1	Constant for feedforward control	-110.0 ... 110.0 %	0.0 %
K ₇ ↘	PA	Input signal point 7 (function generation)	-1999 ... 1999 0.00 ... 19.99	0.0
K ₇ ↗	PA	Output signal point 7 (function generation)	-1999 ... 1999 0.00 ... 19.99	0.0
K ₈	PA/PA2	Correction factor for Y _{ACTUAT} input	0.00 ... 19.99	1.00
K ₈ ↘	PA	Output signal for lower range value (function generation)	-1999 ... 1999 0.00 ... 19.99	0.0
K ₈ ↗	PA	Output signal for upper range value (function generation)	-1999 ... 1999 0.00 ... 19.99	100.0
K ₉	PA/PA1	Constant for feedforward control	-19.99 ... 19.99	0.00
K _P	PA1	Proportional-action coefficient	0.1 ... 100.0	1.0
K _P	PA/PA2	Proportional-action coefficient	0.1 ... 100.0	1.0
K _P K ₁	PA	Amplification of Ao1 output	0.1 ... 10.0	1.0
K _P K ₂	PA/PA1	Amplification of PD element 1	0.1 ... 100.0	1.0
K _P K ₃	PA/PA2	Amplification of PD element 2	0.1 ... 100.0	1.0

Parameter		Designation	Range	Factory default
Name	Set			
K _P Y ₁	PA/PA2	Amplification of output variable Y ₁	0.1 ... 10.0	1.0
K _P Y ₂	PA/PA2	Amplification of output variable Y ₂	0.1 ... 10.0	1.0
T _N	PA/PA2	Reset time	-199 ... 1999 m/s	120.0 s
T _N	PA1	Reset time	-199 ... 1999 m/s	120.0 s
T _s	PA/PA1	Time parameter for reference variable ramp	-199 ... 1999 m/s	1.0 s
T _s K ₁	PA	Time parameter for output ramp or rate of output changes	-199 ... 1999 m/s	1.0 s
T _s K ₂	PA/PA2	Time parameter for change of control action	-199 ... 1999 m/s	0.0 s
T _s W _{EX}	PA/PA1	Time parameter for W _{EX} filter	0.1 ... 100.0 s	0.1 s
T _s X	PA/PA1	Time parameter for X filter	0.1 ... 100.0 s	0.1 s
T _s X _d	PA/PA1	Time parameter for X _d filter	0.1 ... 100.0 s	0.1 s
T _s Z	PA/PA2	Time parameter for Z filter	0.1 ... 100.0 s	0.1 s
T _v	PA/PA2	Derivative-action time	-199 ... 1999 m/s	5.0 s
T _v	PA1	Derivative-action time	-199 ... 1999 m/s	5.0 s
T _v K ₁	PA/PA2	Derivative-action gain	0.1 ... 10.0	1.0
T _v K ₁	PA1	Derivative-action gain	0.1 ... 10.0	1.0
T _v K ₂	PA/PA1	Derivative-action time of PD element 1	-199 ... 1999 m/s	0.1 s
T _v K ₃	PA/PA2	Derivative-action time of PD element 2	-199 ... 1999 m/s	0.1 s
T _{Y1}	PA/PA2	Duty cycle of 3-step output (-)	-199 ... 1999 m/s	60.0 s
T _{Y1} \leq	PA/PA2	Minimum on-time in % of T _{Y1}	0.1 ... 10.0 %	1.0 %
T _{Y2}	PA/PA2	Duty cycle/speed of response 3-step output (+)	-199 ... 1999m/s	60.0 s
T _{Y2} \leq	PA/PA2	Minimum on-time in % of T _{Y2}	0.1 ... 10.0 %	1.0 %
TZ	PA/PA2	Dead band of 3-step output	0.1 ... 100.0 %	2.0 %
TZX _d	PA/PA2	Dead band of error	0.0 ... 110.0 %	0.0 %
TZY ₁	PA/PA2	Dead band point in split-range operation	0.1 ... 100.0 %	0.1 %
TZY ₂	PA/PA2	Dead band point in split-range operation	0.1 ... 100.0 %	100.0 %
W _{EX}	PA/PA1	W _{EX} input	-1999 ... 1999 0.00 ... 19.99	
W _{EX} \leq	PA/PA1	Minimum measuring-range value	-1999 ... 1999 0.00 ... 19.99	0.0
W _{EX} \geq	PA/PA1	Maximum measuring-range value	-1999 ... 1999 0.00 ... 19.99	100.0

Parameter		Designation	Range	Factory default
Name	Set			
W _{IN}	PA/PA1	Internal reference variable	-1999 ... 1999 0.00 ... 19.99	0.0
W _{IN}	PA	Internal set point ratio	0.00 ... 19.99	0.00
W _{IN}	PA2	Internal set point	-1999 ... 1999 0.00 ... 19.99	0.0
W _{IN} ⤴	PA/PA1	Maximum measuring-range value	-1999 ... 1999 0.00 ... 19.9	100.0
W _{IN} ⤴	PA	Maximum limitation of set point ratio	0.00 ... 19.99	19.99
W _{IN} ⤴	PA2	Maximum measuring-range value	-1999 ... 1999 0.00 ... 19.99	100.0
W _{IN} ⤵	PA/PA1	Minimum measuring-range value	-1999 ... 1999 0.00 ... 19.99	0.0
W _{IN} ⤵	PA	Minimum limitation of set point ratio	0.00 ... 19.99	0.00
W _{IN} ⤵	PA2	Minimum measuring-range value	-1999 ... 1999 0.00 ... 19.99	0.0
W _{IN} K ₁	PA2	Minimum limitation of set point	-1999 ... 1999 0.00 ... 19.99	0.0
W _{IN} K ₁ ⤴	PA2	Maximum limitation of set point	-1999 ... 1999 0.00 ... 19.99	100.0
W _{IN} K ₁ ⤵	PA/ PA1	Minimum value of adjustment range of reference variable	-1999 ... 1999 0.00 ... 19.99	0.0
W _{IN} K ₁ ⤴	PA/ PA1	Maximum value of adjustment range of reference variable	-1999 ... 1999 0.00 ... 19.99	100.0
W _{IN} K ₂	PA/PA1	Step change of reference variable	0.0 ... 110.0 %	1.0 %
W _S	PA/PA1	Safety set point	-1999 ... 1999 0.00 ... 19.99	0.0
W _S	PA	Safety set point ratio	0.00 ... 19.99	0.00
W _S ⤵	PA/PA1	Minimum measuring-range value	-1999 ... 1999 0.00 ... 19.99	0.0
W _S ⤴	PA/PA1	Maximum measuring-range value	-1999 ... 1999 0.00 ... 19.99	100.0
X	PA/PA1	X input	-1999 ... 1999 0.00 ... 19.99	
X ⤵	PA/PA1	Minimum measuring-range value	-1999 ... 1999 0.00 ... 19.99	0.0
X ⤴	PA/PA1	Maximum measuring-range value	-1999 ... 1999 0.00 ... 19.99	100.0
X _d	PA/PA1	Error	-110 ... 110 %	
X _d	PA2	Error	-110.0 ... 110.0 %	

Parameter		Designation	Range	Factory default
Name	Set			
X _{SdG1}	PA/PA1	Differential gap of limit relay 1	0.1 ... 100.0 %	0.5 %
X _{SdG2}	PA/PA2	Differential gap of limit relay 2	0.1 ... 100.0 %	0.5 %
X _{SdY1}	PA1	Differential gap of limiting controller	0.1 ... 100.0%	5.0 %
X _{SdY2}	PA/PA2	Differential gap of on-off/3-step output	0.1 ... 100.0 %	0.3 %
Y ₁	PA/PA2	Output variable Y ₁	-10.0 ... 110.0 %	
Y ₁ \leq	PA/PA2	Output variable limitation; min. value	-10.0 ... 110.0 %	-10.0 %
Y ₁ \geq	PA1	Output variable limitation; min. value	0.0 ... 110.0 %	0.0 %
Y ₁ \leq	PA/PA2	Output variable limitation; max. value	-10.0 ... 110.0 %	110.0 %
Y ₁ \geq	PA1	Output variable limitation; max. value	0.0 ... 110.0 %	100.0 %
Y ₁ K ₁	PA/PA2	Safety output value	-10.0 ... 110.0 %	-10.0 %
Y ₁ K ₂	PA/PA2	Amplification of threshold	0.0 ... 110.0	1.0
Y ₁ K ₃	PA/PA2	Constant for Y _{PID}	-10.0 ... 110.0 %	-10.0 %
Y ₁ K ₄	PA1	Safety output value	-10.0 ... 110.0	-10.0
Y ₁ K ₅	PA	Constant	0.0 ... 110.0	0.0
Y ₂	PA/PA2	Output variable Y ₂	-10.0 ... 110.0 %	
Y ₂ \leq	PA/PA2	Output variable limitation; min. value	-10.0 ... 110.0 %	-10.0 %
Y ₂ \geq	PA/PA2	Output variable limitation; max. value	-10.0 ... 110.0 %	110.0 %
Y ₂ K ₁	PA/PA2	Safety output value	-10.0 ... 110.0 %	-10.0 %
Y ₂ K ₂	PA/PA2	Amplification of threshold	0.0 ... 110.0	1.0
Y ₂ K ₃ \leq	PA/PA2	Minimum switching point Permanent signal	-10.0 ... 110.0	0.0
Y ₂ K ₃ \geq	PA/PA2	Maximum switching point Permanent signal	-10.0 ... 110.0	100.0
Z	PA/PA2	Z input	-1999 ... 1999 0.00 ... 19.99	
Z	PA	External set point ratio	0.00 ... 19.99	
Z \leq	PA/PA2	Minimum measuring-range value	-1999 ... 1999 0.00 ... 19.99	0.0
Z \geq	PA	Minimum limitation Set point ratio	0.00 ... 19.99	0.00
Z \leq	PA/PA2	Maximum measuring-range value	-1999 ... 1999 0.00 ... 19.99	100.0
Z \geq	PA	Maximum limitation Set point ratio	0.00 ... 19.99	19.99

Index

A

Actual value	
current ~ as reference variable.....	25
increase or decrease in.....	30
Adaptation of control parameters	155
See also EB 6412 EN	
Adjustment of zero and span.....	136
See also EB 6412 EN	
Analog inputs.....	8
adjustment of zero and span.....	136
assignment of	12, 135
Analog output	92
assignment of	154

B

Binary inputs	24 - 34
changeover to digital display	33
configuration	137 - 139
minimum pulse duration	24
status query	24
Binary outputs	31, 91 - 92
configuration	153

C

Cascade control	42 - 47
display of the reference variable	42
interruption of the cascade.....	42
modification of the follower controller ref v	44
with external reference variable	42
with internal reference variable	42
Change of control action.....	116 - 118, 145
via binary input	34
Changeover of reference variable.....	24
Changeover of set point	
See changeover of reference variable	
Closed position of the control valve	128, 151
Collective fault message	13
Configuration data and parameter protection	34
Configuration table.....	129 - 159
Configuration via external software	
See TROVIS 6482	
Control modes.....	36 - 71, 129

Controller outputs	
dynamic behavior.....	106 - 111, 142
locking of output signals.....	30
operating direction	82 - 87, 147
D	
Dead band for three-step output.....	79
Dead band point.....	84
Dead band, error.....	73
Derivative controller	
See PD controller	
Derivative-action gain	109 - 110
Derivative-action time	109 - 110
Digital display	
changeover via binary input.....	33
configuration	120 - 126, 131
decimal point	128
repetition rate.....	128, 153
E	
Adjustment	12
Error	
display range of	128, 154
filtering of	14
inversion of	83, 133
repetition rate of display	128, 153
Error messages	
See EB 6412 EN	
Exceeding input measuring range	
manual/automatic transfer.....	149
Exceeding the measuring range	13
F	
Factory default	
See also EB 6412 EN	
reset to.....	119, 157
Falling below input measuring range	
manual/automatic transfer.....	149
Falling below the measuring range.....	13
Fault indication output	
See binary outputs	
Feedforward control.....	49 - 71
for cascade control	62
for follow-up control	56
for limiting control	66

for ratio control.....	58
Filtering	
of error	14
of input variables	14, 144
Fixed set point control	37
Follow-up control.....	38 - 39
reference variable changeover	38
with external reference variable	38
with internal/external reference variable	38
Follower controller.....	42
Follower controller mode	
changeover to.....	31
Function generation	16 - 23, 133
example 1 for.....	18
example 2 for.....	20
example 3 for.....	22
I	
I-action component	
adaptation of.....	106, 112
Input boards.....	10 - 11
Input circuitry	8 - 9
Input variable of D element.....	143
Input variables	
See also analog inputs	
linking of.....	49
Integral controller	
See PI, PID controller	
L	
Limit relay	
activation via binary input	33
assignment	89 - 90, 150 - 151
differential gap (hysteresis)	89
for cascade control.....	89
for ratio control.....	89
Limitation	
of the rate of output changes.....	26, 148
Limiting control.....	46
selection of the maximum output variable.....	46
selection of the minimum output variable.....	46
with external reference variable	46, 66
with internal reference variable	46, 66

Limiting control	
configuration	147
Limiting controller	46
Locking of operator keys	159

M

Manual mode	
changeover via binary input	32
Master controller	42
Measuring range monitoring function	
locking of manual mode when	33
Monitoring the measuring range	8

O

Operating direction	
of input variables	84
Operating point	114
Operating point adjustment	
manual/ automatic changeover	114
via manual mode	114, 144
via reference variable	114, 146
Output ramp	99 - 103, 148
initialization via binary input	26
Output signal limitation	88
continuous	147
fixed	149
in manual mode	149
Output variable	
assignment of displays	127, 149
inversion of displays	127, 150

P

P controller	107
P2I controller	111
Parameter set PA1	42, 46
Parameter set PA2	42, 46
Parameter table	161 - 165
PD controller	109
PD elements	50
PI controller	108
PID controller	110
Position correction	32
Power frequency	119
Power supply failure	
See also EB 6412 EN	

restart after	152
Primary controller	46
Proportional controller	
See P controller	
Proportional-action coefficient	108 - 111
Pt 100 resistance thermometer	10
R	
Range of output variable	
correction of	112
Ratio control	
with internal or external ratio	40
with internal ratio	40
Reference junction sensor	11
Reference variable	
assignment of internal	104 - 105, 141
correction of internal	104
linking of the reference variables	104
upon failure of external system	24, 140
Reference variable changeover	31
Reference variable ramp	95 - 98, 136
initialization via binary input	26
See reference variable ramp	
Reset time	108, 110 - 111
Resistance thermometer	
See Pt 100	
Root-extraction	15, 134
RS 485 interface	
See EB 6412 EN	
S	
Safety output values	93 - 94
Safety set point	
setting the ~ as reference variable	25
Serial interface	
See EB 6412 EN	
Signal ranges	
controller outputs, analog output	82
Split-range operation	82 - 87
Synchro control	48
System deviation	107, 109, 114
System not ready	24

T T_N

See Reset time

 T_V

See Derivative-action time

 T_VK1

See Derivative-action gain

Thermocouple 10 - 11

Transmitter fault

See Monitoring the measuring range

Transmitter input 10

TROVIS 6482

See EB 6412 EN

X

X-tracking 106, 142

Y

Y-tracking 32



SAMSON AG · MESS- UND REGELTECHNIK
Weismüllerstraße 3 · 60314 Frankfurt am Main · Germany
Phone +49 69 4009-0 · Fax +49 69 4009-1507
Internet: <http://www.samson.de>

KH 6412 EN

S/Z 11/2004