

SAMSON

---

# SOLUTIONS FOR THE POWER INDUSTRY

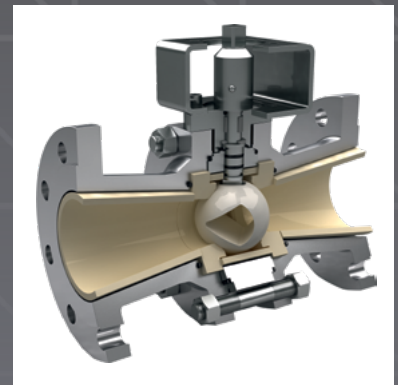
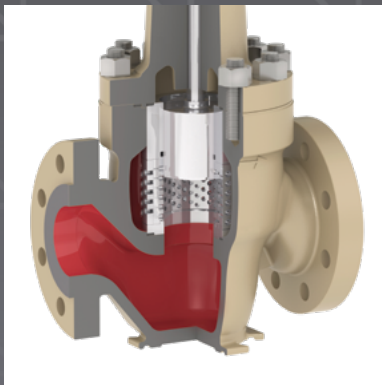

# POWER GENERATION: AN OVERVIEW

---

The generation of electric power is a fundamental part of modern civilization. Demand continues to increase as a result of the heavy reliance we have on electricity in our daily lives, and the world's ongoing industrialization and urban development. Given the significant strains placed on current electrical power systems, the need for efficient and economical generation is more critical than ever before. To meet these growing needs, we need to capitalize on a combination of power generation methods.

## Coal

---

Coal is the most abundant fuel in the world, accounting for over 33% of global electrical power generation. Control valves are required to efficiently handle the fuel throughout every stage of the energy creation process.



## Natural Gas

Natural gas power generation is growing in popularity and accounts for a large majority of new plants. The proper selection of control valves is especially important as the higher temperatures and pressures of a natural gas fired power plant present significant challenges.

## Combined Cycle

---

Combined cycle generation increases overall efficiencies by using waste heat to drive a second energy creation cycle. In comparison to coal and natural gas, the primary difference is that there is reduced space and equipment requirements due to the use of heat recovery steam generation (HRSG).



## Cogeneration & Trigeneration

Cogeneration and trigeneration use waste energy as thermal energy for heating (cogeneration) as well as cooling through an absorption chiller (trigeneration).

## Nuclear

---

A nuclear power plant is a thermal power station that uses a nuclear reactor as its heating source. All equipment in a nuclear plant is required to meet strict safety and functionality standards.



## Renewable Sources

Renewable energy generation is highly desirable because it is sustainable and it has very low (or in some cases, even zero) environmental impact. With respect to control valves, solar thermal renewable power generation offers the greatest opportunity.

# IMPLEMENT THE RIGHT CONTROL VALVE FOR GENERAL SERVICE APPLICATIONS

---

## PROCESS CONTROL (FEED REGULATION)

Process control (also known as feed regulation) is the most general application for a control valve and one for which SAMSON offers a complete line of control valves to choose from. In these types of applications, a control valve manages the process fed to a pressurized control loop in response to a control signal. This signal can be used to maintain any type of process variable but the most common are flow, pressure, temperature, and level. “Control”, “regulate” and “throttle” are just a few of the terms you’re likely to hear in association with these applications.



## LOW SEAT LEAKAGE (TIGHT SHUTOFF)

For many applications, minimal process leakage or “tight shutoff” must be maintained to ensure correct plant operation. While isolation valves should always be used to provide the highest level of shutoff, control valves are often called upon to provide optimal sealing performance while maintaining accurate control of the process. SAMSON offers a wide range of control valves with low leakage designs. How? Through our use of resilient materials, lapping methods, and advanced engineering concepts that enable us to achieve precise valve sealing.

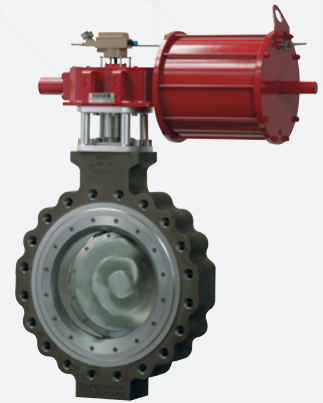

## STEAM CONDITIONING

Steam as it is produced is rarely at an ideal condition for the desired application usage. That’s where steam conditioning comes into play. In nearly every application, at least some degree of conditioning or desuperheating is necessary in order to control pressure and temperature, protect downstream equipment, enhance energy efficiency, and optimize performance. For mechanical duties, dry superheated steam is ideal whereas superheated steam for heat transfer tends to be inefficient. SAMSON offers control valves suitable for steam conditioning and desuperheating, and our most popular is the unique 3281 Steam Conditioning Control Valve.

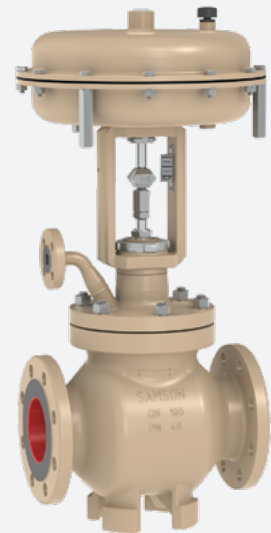



# CHOOSING HEAVY DUTY CONTROL VALVES FOR SEVERE SERVICE APPLICATIONS IS CRITICAL

---

## CONTINUOUS LETDOWN

In a continuous letdown application, a large constant differential pressure is maintained and flow is controlled by the valve position. Accuracy of control is extremely important to ensure near constant pressure, flow, or temperature conditions. Not only must you address severe service conditions from the large pressure drop, but you also need a control valve design capable of high rangeability. In these applications, a few of the most common terms include “letdown”, “blowdown”, “attemperation”, and “pressure reducing”. SAMSON offers a wide range of trim designs to meet all process conditions associated with continuous letdown applications.



## INTERMITTENT LETDOWN

Intermittent letdown valves bypass the process during start-up, shutdown, load rejection, or a safety event. This can be an entire or partial system bypass. In both cases, these valves must not only handle the large pressure reduction but also the expansion and cooling of the system under bypass. When you're dealing with these types of applications, you'll probably hear these terms: “bypass”, “vent”, “dump”, “reject”, and “flare”. SAMSON's control valve solutions for intermittent letdown applications save energy, allow for quicker startup, and better cope with load rejection events.

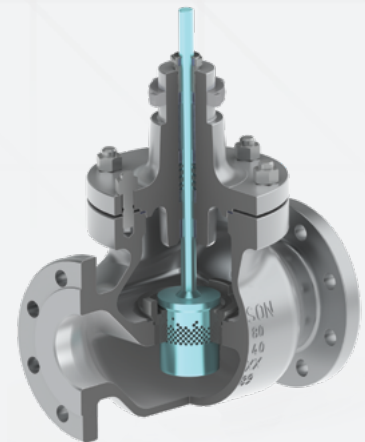

## RECIRCULATION

Recirculation is a subset of intermittent letdowns associated with a situation where a pump or compressor is bypassed, and the fluid that was pressurized (or compressed) is reduced and returned to the pump inlet. When a main pump or compressor is bypassed, you'll find yourself in the most severe of applications. Why? Because this is the highest pressure drop of your entire plant and it requires special consideration in order to ensure reliable long-term operation. SAMSON's control valves for these applications are exclusively designed to handle even the most serious conditions encountered in recirculation applications. If you're dealing with such an application, expect to hear terms such as “return”, “recirculation”, “recycle”, “kickback”, and “surge control”.



# SPECIALTY APPLICATIONS CALL FOR SPECIALTY CONTROL VALVES

---

## HIGH TEMPERATURE

The complexity of the control application amplifies as process temperatures increase. If the incorrect materials of construction are specified, higher temperatures present metal failure issues such as metallurgical instability, creep, and insufficient yield strength. In such high temperatures, you also need to protect non-metallic components such as control valve soft goods and heat sensitive electronics. SAMSON has considerable experience designing control valves for the protection of these non-metallic components, and also manufacturing valves in a variety of metals that are capable of handling extremely high temperatures and thermal cycling.

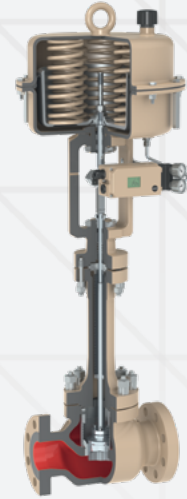

## CORROSIVE ENVIRONMENTS

Corrosion is a serious issue for control valves in power generation plants. Prior to entering a high-pressure boiler, the water used in power generation must be of the highest purity with all dissolved gasses removed. A further example is the decontamination and waste removal systems used in coal fired power plants. SAMSON's use of corrosion-resistant materials include PTFE and PFA lined valves. Limiting fluid velocities also helps to reduce the occurrence and severity of corrosion damage.



## EROSION & ABRASION

Process applications that exhibit erosive and abrasive characteristics require special attention. Severe process conditions can cause erosion while entrained particles in the process (often called slurries, sludges, and ashes) are very abrasive. Throttling control valves used in these erosive and abrasive applications require the use of special designs and hardened materials. With our highly specialized designs and use of heavy duty materials such as ceramics, SAMSON can address even the most serious applications.

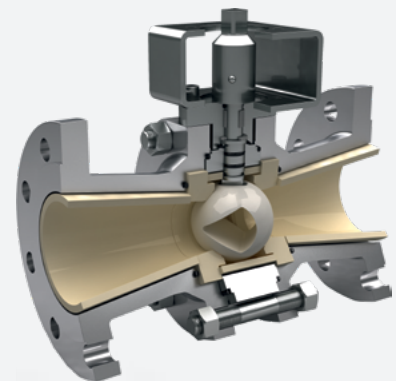

# POWER INDUSTRY PRODUCTS

# SAMSON

PFEIFFER · RINGO · SED · STARLINE · VETEC  
AIR TORQUE · CERA SYSTEM · LEUSCH

## VALVES

- Control and on/off valves used extensively in the most demanding conditions
- Suitable for extreme pressures and temperatures in severe service
- Designs include globe, ball, butterfly, and rotary plug valves

## ACTUATORS

- Solutions for pneumatic, hydraulic, and electric applications
- Designs include scotch yoke, rack-and-pinion, and linear actuators
- Available in a wide variety of materials suitable for use in demanding applications

## SMART DEVICES

- Digital positioners for linear and rotary valves that work in extreme conditions
- Available for both HART® and FOUNDATION™ fieldbus communication
- Easy operation with state-of-the-art valve diagnostics

**SAMSON**  
PFEIFFER · RINGO · SED · STARLINE · VETEC  
AIR TORQUE · CERA SYSTEM · LEUSCH

## SAMSON Controls Inc.

4111 Cedar Blvd. Baytown, TX 77523-8588 USA  
Phone: +1 281-383-3677 · Fax: 281-383-3690



[www.samsoncontrols.com](http://www.samsoncontrols.com)



[contact-us@samsongroup.com](mailto:contact-us@samsongroup.com)