

T 3009 EN

Type 42-10 RS Check Valve (backflow protection)

Series 42 Self-operated Regulators



Application

Designed to protect water, steam, nitrogen and compressed air networks against backflow from directly connected systems. Differential pressure set point $\Delta p = 0.2 \text{ bar}$ · Valve size **DN 15 to 150** · Pressure rating **PN 16 to 40** · Liquids up to **150 °C** · Compressed air and nitrogen up to **80 °C (150 °C)**¹⁾ · Saturated steam using a compensation chamber up to **220 °C**

The regulator prevents flowback from directly connected systems.

The regulator is opened when the upstream pressure is at least 0.2 bar greater than the downstream pressure. It is closed automatically when the downstream pressure rises to or above the value of the upstream pressure.

The regulator closes reliably to prevent backflow from the plant into the compressed air or nitrogen network. The soft-seated plug and seat trim complies with leakage class VI.

Special features

- Low-noise, medium-controlled proportional regulators requiring little maintenance
- In the event of a diaphragm rupture, the undamaged operating diaphragm takes over the function of the damaged diaphragm
- Reliable functioning even in the event of a power failure or when other instruments in the control circuit malfunction
- Diaphragm rupture indicator
- Fixed set point
- Regulators delivered ready to install without supplementary devices, meaning no additional installations or start-ups are necessary
- Low purchase and installation costs
- Valve body optionally available in cast steel, cast stainless steel or forged stainless steel
- All wetted parts are free of non-ferrous metal
- External adjustment not possible
- Backflow only leads to a minimum amount of leakage (leakage class VI) due to the soft-seated plug
- Increasing downstream pressure supports tight shut-off of the valve

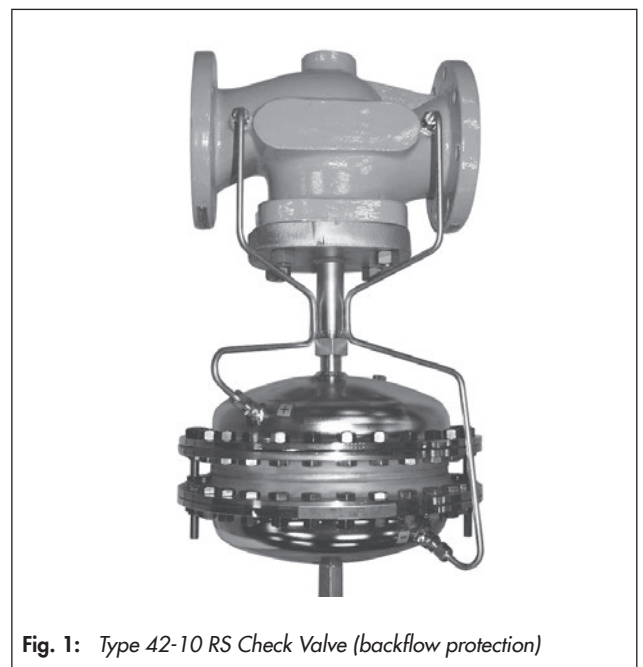

Fig. 1: Type 42-10 RS Check Valve (backflow protection)

Versions

Check valve in supply pipelines

Type 42-10 RS · Type 2421 RS Valve, DN 15 to 150 · Type 2420 RS Actuator with two diaphragms · Set point fixed at 0.2 bar · Version suitable for steam · Version for deionized water · Oil-resistant version for liquids on request

Optional: diaphragm rupture indication with pressure switch · Fittings and diaphragm rupture indicator made of Monel®

¹⁾ Version with FKM diaphragm

Principle of operation

The medium flows through the valve in the direction indicated by the arrow. The position of the valve plug (3) determines the differential pressure over the cross-sectional area released between the plug and seat (2). The valve is closed by the springs in the normal position.

At a differential pressure of 0.2 bar, the valve begins to open; at 0.35 bar, the valve is completely open. At this point, the upstream pressure p_1 (compressed air or nitrogen network pressure) must be greater than the downstream pressure p_2 . The valve closes automatically when the downstream pressure rises to or above the value of the upstream pressure.

The standard plug is soft-seated to ensure tight shut-off and to prevent backflow from the plant into the compressed air or nitrogen network.

The mounted control lines (14) transmit the upstream (+) pressure and downstream (-) pressure to the actuator.

The actuator with two diaphragms (11) offers increased safety and reliability of functions. The operating diaphragm for upstream pressure (11.1) is connected to the valve input pressure (+), whereas the operating diaphragm for downstream pressure (11.2) is connected to the valve output pressure (-). A hole with a mechanical diaphragm rupture indicator (12) is located in the intermediate ring between the two diaphragms, which responds at approx. 1.5 bar. In the event of a diaphragm rupture, the pressure in the space between the two operating diaphragm starts to increase. This causes the pin in the diaphragm rupture indicator to be pushed outwards and a red ring appears, indicating the diaphragm rupture. The intact operating diaphragm takes on the control task of the ruptured diaphragm.

A pressure switch (15) can be optionally mounted to the actuator to trigger an alarm.

After a diaphragm rupture is indicated, we recommend replacing both diaphragms.

Sample application

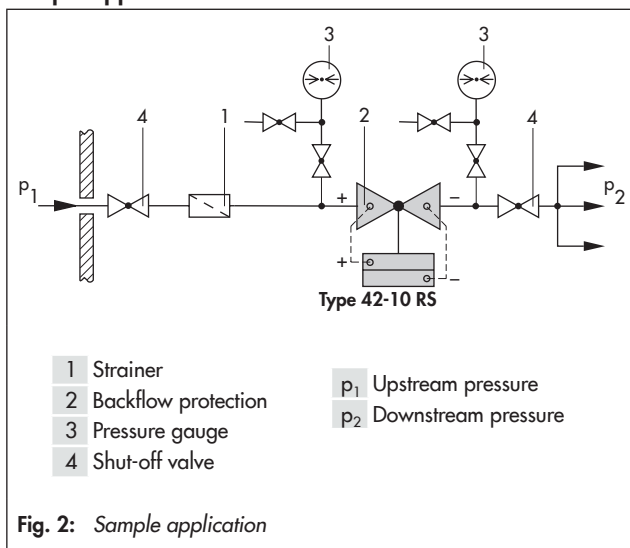
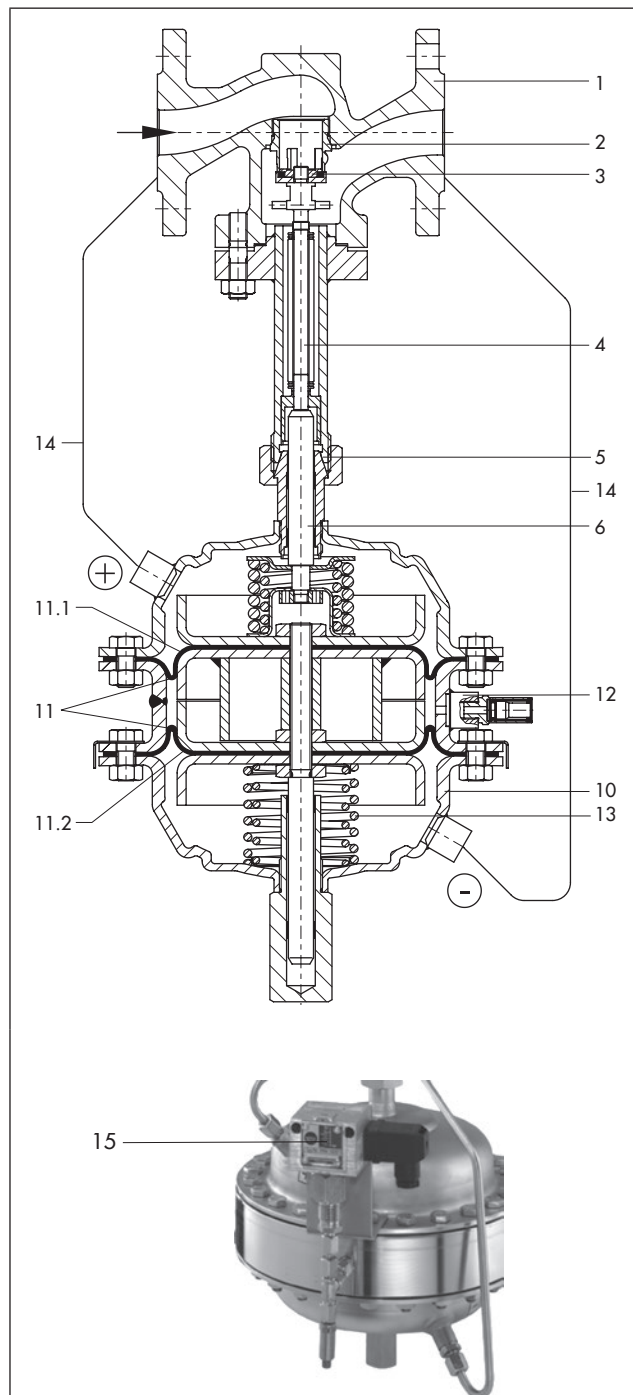

Fig. 2: Sample application



- | | |
|------|---|
| 1 | Valve body |
| 2 | Seat |
| 3 | Plug |
| 4 | Plug stem |
| 5 | Coupling nut (to connect diaphragm actuator) |
| 6 | Actuator stem |
| 10 | Actuator housing |
| 11 | Two diaphragms |
| 11.1 | Operating diaphragm for upstream pressure (+) |
| 11.2 | Operating diaphragm for downstream pressure (-) |
| 12 | Diaphragm rupture indicator |
| 13 | Set point springs |
| 14 | Control line 8x1 mm |
| 15 | Pressure switch (optional) |

Fig. 3: Functional diagram

Table 1: Technical data

Type 2421 RS Valve											
Valve size	15	20	25	32	40	50	65	80	100	125	150
K _{V5} coefficient	4	6.3	8	16	20	32	50	80	125	190	280
Pressure rating	PN 16, PN 25, PN 40										
Max. constant operating pressure	25 bar										
Max. perm. pressure acting on one side	45 bar										
Leakage class acc. to IEC 60534-4 ¹⁾	Leakage rate VI										
Max. permissible temperature	See Type 2420 RS Actuator										
Conformity	CE EAC										
Type 2420 RS Actuator											
Actuator area	320 cm ²						640 cm ²				
Differential pressure set point Δp , fixed	0.2 bar · 0.3 bar ²⁾										
Max. permissible temperature	80 °C for air and gases · 150 °C for water · 220 °C for steam using a compensation chamber										
With EPDM diaphragm	150 °C for air and gases										
With FKM diaphragm											
Conformity	CE										

¹⁾ Terms for control valve sizing according to IEC 60534: $F_L = 0.95$, $X_T = 0.75$

²⁾ Special version on request

Table 2: Materials · Material numbers according to DIN EN

Type 2421 RS Valve			
Pressure rating	PN 16, 25 and 40		PN 40
Valve body	Cast steel 1.0619	Cast stainless steel 1.4408	Forged stainless steel 1.4404 ¹⁾
Seat and plug	Stainless steel 1.4404 with EPDM soft seal, FKM soft seal or PTFE soft seal		
Plug stem	Stainless steel 1.4301		
Bottom section	Stainless steel 1.4404/1.4301		
Body gasket	novatec® PREMIUM		
Type 2420 RS Actuator			
Diaphragm cases	1.0332	Stainless steel 1.4301	
Diaphragm	EPDM with fabric reinforcement · FKM with fabric reinforcement		
Guide bushing	DU bushing	PTFE bushing	
Intermediate piece	Sheet steel DD11	Stainless steel 1.4301	
Coupling pin	Stainless steel 1.4301		
Seals	EPDM · FKM		

¹⁾ DN 15, 25, 40 and 50 only

Installation

The regulator is delivered ready for installation.

The following points must be observed:

- Install the valves in horizontal pipelines free of stress with the actuator suspended downwards (see Fig. 4).
- The direction of flow must match the direction indicated by the arrow on the body.
- Install a strainer upstream of the valve.

Dimensions

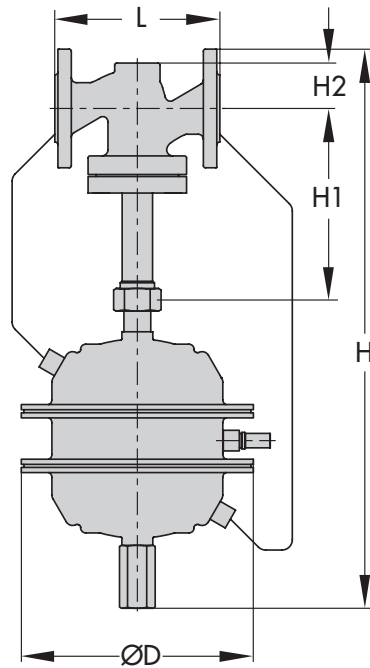

Dimensions in mm and weights in kg

Valve size DN	15	20	25	32	40	50	65	80	100	125	150
Length L	130	150	160	180	200	230	290	310	350	400	480
Height H1	225						300		355	460	590
Height H2	Other materials		44		72		100		120	145	175
	Forged steel		53	-	70	-	92	98	-	-	-
Height H ¹⁾	550			600			800		830	1000	
Actuator	ØD = 285 mm · A = 320 cm ²						ØD = 390 mm · A = 640 cm ²				
Weight, approx. kg	26	26.5	28	35	35.5	39.5	59.5	65.5	75	110	165

¹⁾ Minimum clearance required to remove the actuator: +100 mm

Fig. 4: Dimensions

Ordering text

Type 42-10 RS Check Valve (backflow protection)
 (= Valve 4210 RS + Actuator 2420 RS + Mounting kit M4210 RS)

Set point fixed at 0.2 bar

DN ...

Body material ...

PN ...

Special version

Table 3: Flow rates for Type 2421 RS Valve**Table 3.1: Flow rates for nitrogen**

0.25 bar pressure drop across the valve

DN	15	20	25	32	40	50	65	80	100	125	150	
K_{Vs}	4	6.3	8	16	20	32	50	80	125	190	280	
Maximum flow rate of nitrogen in Nm³/h at 20 °C · 0.25 bar pressure drop across the valve												
Inlet pressure p_1 (gauge) in bar	2	82.19	129.4	164.5	328.8	411.3	658	1028	1645	2160	3907	5758
	3	95.9	151	191.8	383.6	497.7	767.5	1199	1918	2519	4557	6716
	4	107.8	169.9	215.8	431.5	539.5	863.3	1349	2158	2833	5126	7554
	5	118.6	186.9	237.4	474.6	593.5	949.5	1483	2374	3116	5638	8309
	6	128.5	202.4	257.1	514.2	642.9	1028	1607	2571	3376	6108	9001
	8	146.3	230.5	292.8	585.5	732	1171	1830	2928	3844	6954	10240
	10	162.2	255.6	324.6	649.1	811.5	1298	2029	3246	4261	7709	11360
	12	176.7	278.4	353.6	707.1	884	1414	2210	3536	4641	8398	12370
	15	196.5	309.6	393.1	786.2	982.9	1572	2457	3931	5161	9338	13760
	20	225.7	355.6	451.6	903.1	1129	1806	2822	4516	5928	10720	15800
	25	251.7	396.4	503.4	1006	1258	2013	3146	5034	6608	11950	17620

Table 3.2: Flow rates for air

0.25 bar pressure drop across the valve

DN	15	20	25	32	40	50	65	80	100	125	150	
K_{Vs}	4	6.3	8	16	20	32	50	80	125	190	280	
Maximum flow rate of air in Nm³/h at 20 °C · 0.25 bar pressure drop across the valve												
Inlet pressure p_1 (gauge) in bar	2	80.95	127.5	161.8	323.4	404.5	647.2	1011	1618	2125	3843	5663
	3	94.32	148.5	188.7	377.3	471.8	754.8	1179	1887	2478	4482	6605
	4	106.1	167.1	212.2	424.4	530.7	849.1	1326	2122	2787	5042	7430
	5	116.7	183.8	233.4	466.8	583.7	933.9	1459	2335	3065	5545	8172
	6	126.4	199.1	252.9	505.8	632.4	1011	1581	2529	3320	6008	8853
	8	143.9	226.7	288	575.9	720	1152	1800	2880	3780	6840	10080
	10	159.6	251.4	319.2	638.5	798.2	1277	1995	3193	4191	7583	11170
	12	173.8	273.5	347.8	695.5	869.5	1391	2174	3478	4565	8261	12170
	15	193.3	304.5	386.7	774	966.9	1547	2417	3867	5076	9185	13530
	20	222.1	349.8	444.2	888.5	1110	1777	2776	4442	5831	10550	15550
	25	247.8	390	495.3	990.6	1238	1981	3095	4953	6501	11760	17330

