

T 8015 EN

Series 240 · Type 3241-1 and Type 3241-7 Pneumatic Control Valves

Type 3241 Globe Valve

DIN version



Application

Control valve for process engineering and industrial applications

Valve size	DN 15 to 300
Pressure rating	PN 10 to 40
Temperatures	-196 to +450 °C

Special features

Type 3241 Globe Valve operated with

- Type 3271 Pneumatic Actuator (Type 3241-1 Control Valve)
- Type 3277 Pneumatic Actuator (Type 3241-7 Control Valve)

Valve body made of

- Cast iron
- Spheroidal graphite iron
- Cast steel, cast stainless steel or cast cold-resisting steel
- Forged steel or forged stainless steel
- Special materials

Undivided valve bonnet up to DN 150

Valve plug

- Metal seal
- Soft seal
- High-performance metal seal

Optional with RFID tags with unique identification according to DIN SPEC 91406.

The control valves with their modular design can be equipped with various accessories:

Positioners, limit switches, solenoid valves and other accessories according to IEC 60534-6-1¹⁾ and NAMUR recommendation. Refer to Information Sheet ▶ T 8350 for more details.

Versions

Standard version for temperatures ranging from -10 to +220 °C or for valves sizes DN 200 to 300, also adjustable high-temperature packing from -10 to +350 °C

- **Type 3241-1** (Fig. 1 and Fig. 3) · DN 15 to 300 with Type 3271 Pneumatic Actuator (see Data Sheets ▶ T 8310-1, ▶ T 8310-2 and ▶ T 8310-3)
- **Type 3241-7** (Fig. 2) · DN 15 to 150 with Type 3277 Pneumatic Actuator for integral positioner attachment (see Data Sheet ▶ T 8310-1)

¹⁾ Accessories required. See associated actuator documentation.

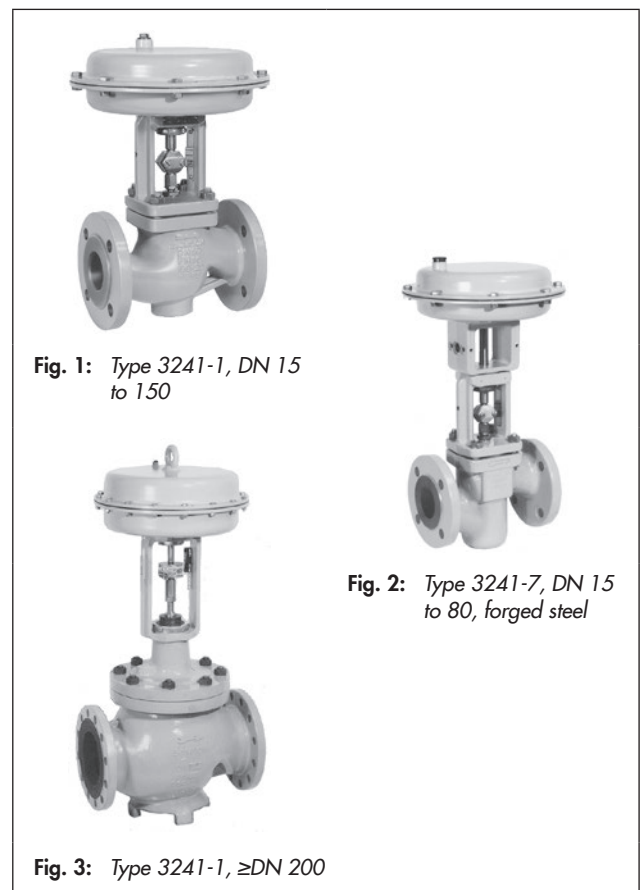

Further versions:

- **Welding ends**
- **Adjustable packing** · See Information Sheet ▶ T 8000-1
- **Flow divider or AC-1 Trim** for noise reduction · See Data Sheets ▶ T 8081 and ▶ T 8082
- **Perforated plug** · ▶ T 8086
- **Valve plug with pressure balancing** · See Technical data

- **Insulating section or bellows seal** · See Technical data
- **Stainless steel actuator** · See Data Sheet ▶ T 8310-1
- Heating jacket · On request
- **Additional handwheel** · See Data Sheets ▶ T 8310-1, ▶ T 8310-2 and ▶ T 8310-3
- **Type 3241 PSA** · Version for pressure swing adsorption plants · See Data Sheets ▶ T 8015-1 and ▶ T 8012-1
- **Version tested according to DIN EN 14597** · For heat generator (see Data Sheet ▶ T 8016)
- **DIN/DVGW-tested version for gas according to DIN EN 161:2013-04** (see Data Sheet ▶ T 8020-2)
- **ANSI version** · See Data Sheet ▶ T 8012
- **Versions with dimensions according to Japanese Industry Standard (JIS)** · Details on request

Design and principle of operation

The medium flows through the valve in the direction indicated by the arrow. The valve plug position determines the cross-sectional area between the seat and plug.

Depending on how the springs are arranged in the pneumatic actuator (see Data Sheets ▶ T 8310-1 and ▶ T 8310-2), the valve has two different fail-safe positions that become effective when the supply air fails:

- **Actuator stem extends (fail-close)**
The valve closes when the supply air fails.
- **Actuator stem retracts (fail-open)**
The valve opens when the supply air fails.

Fig. 4 to Fig. 7 show configuration examples.

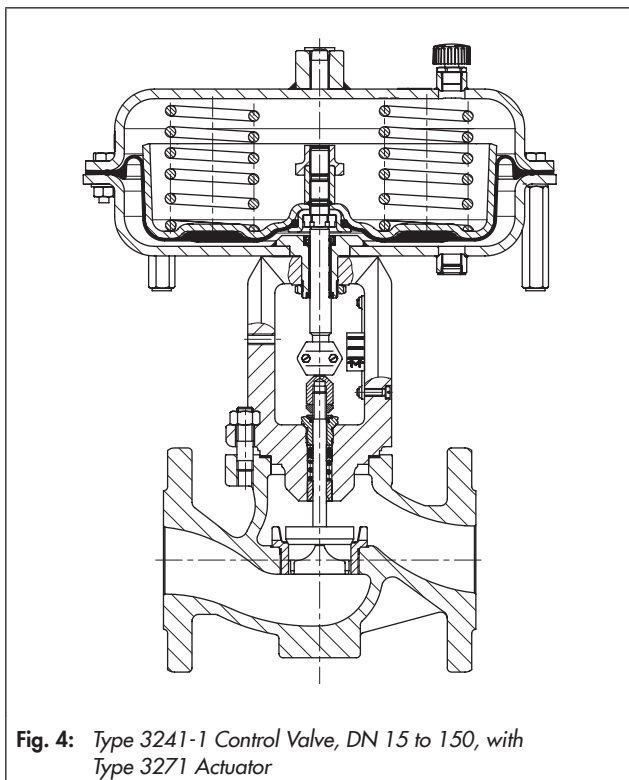

Fig. 4: Type 3241-1 Control Valve, DN 15 to 150, with Type 3271 Actuator

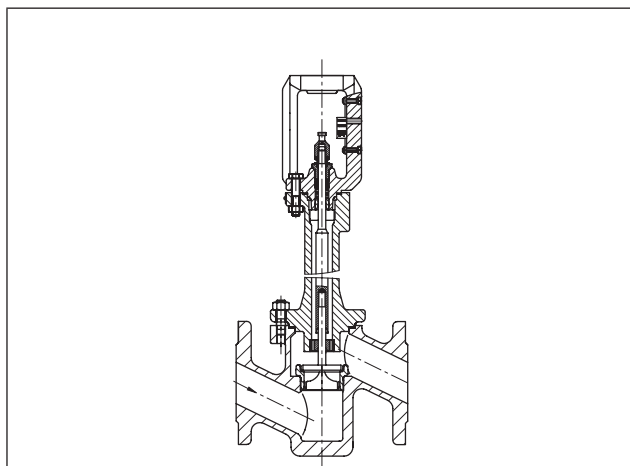

Fig. 5: Type 3241 Valve, forged steel version, DN 15 to 80, with insulating section

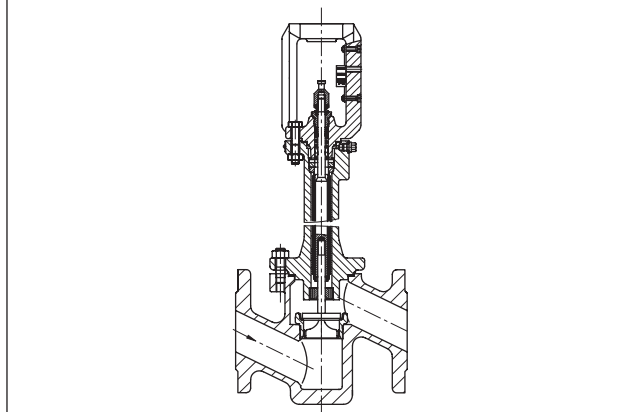

Fig. 6: Type 3241 Valve, forged steel version, DN 15 to 80, with bellows seal

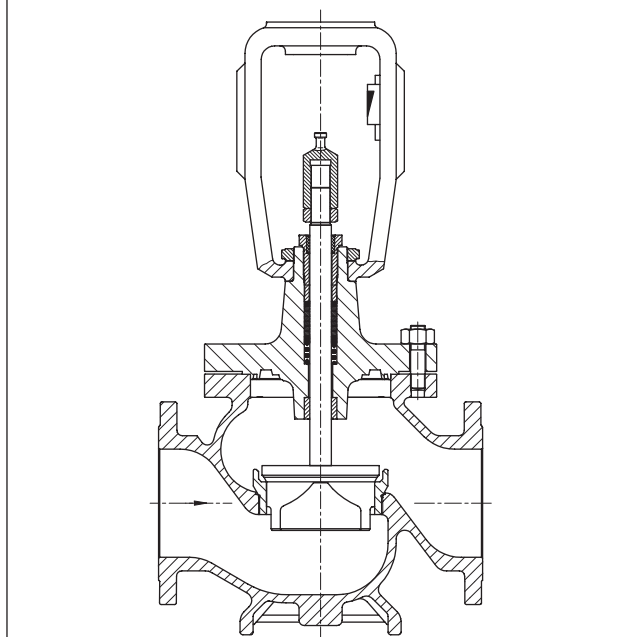

Fig. 7: Type 3241 Valve, DN 200 to 300

Technical data

Table 1: Technical data for Type 3241

Valve size	DN	15 to 250	15 to 150	15 to 300				15 · 25 · 40 · 50 · 80	
Material		Cast iron EN-GJL-250 (EN-JL1040)	Sph. graphite iron EN-GJS-400-18-LT (EN-JS1049)	Cast steel 1.0619	Cast stainless steel 1.4408	Cast steel 1.6220/1.1138	Cast stainless steel 1.4308	Forged steel 1.0460	Forged stainless steel 1.4404
Pressure rating	PN	10 · 16	16 · 25	10 · 16 · 25 · 40					
Type of connection	Flanges	All DIN versions							
	Welding ends	-			DIN EN 12627 only for DN 25, 40, 50, 80, 100, 150, 200, 250, 300				-
Seat-plug seal	Metal seal · Soft seal · High-performance metal seal								
Characteristic	Equal percentage · Linear (according to Information Sheet ► T 8000-3)								
Rangeability	50:1 for DN 15 to 50 · 30:1 for DN 65 to 150 · 50:1 for DN 200 and larger								
Heating jacket	Up to DN 100: PN 25 · DN 125 and larger: PN 16								
RFID tag (optional)	Application range according to the technical specifications and the explosion protection certificates. Documents ► www.samsongroup.com > Service & Support > Electronic nameplate								
Conformity	CE · UK · EAC								
Temperature ranges in °C · Permissible operating pressures acc. to pressure-temperature diagrams (see Information Sheet ► T 8000-2)									
Body without insulating section		All valve sizes: -10 to +220 · Valve sizes DN 200 to 300 with high-temperature packing: -10 to +350							
Body with	Insulating section	-10 to +300	-10 to +350	-10 ⁵⁾ to +400 ¹⁾	-50 to +450 ²⁾	-50 to +300	-50 to +300 ²⁾	-10 ⁵⁾ to +400	-50 to +450
	Long ³⁾	-			-196 to +450	-	-196 to +300	-	-196 to +450
	Bellows seal	-10 to +300	-10 to +350	-10 ⁵⁾ to +400 ¹⁾	-50 to +450 ²⁾	-50 to +300	-50 to +300 ²⁾	-10 ⁵⁾ to +400	-50 to +450
	Long ³⁾	-			-196 to +450	-	-196 to +300	-	-196 to +450
Valve plug	Standard	Metal seal	-196 to +450						
		Soft seal	-196 to +220						
	Balanced	PTFE ring	-50 to +220 · Lower temperatures on request						
		With graphite ring	10 to 450						
RFID tag (optional)	Max. permissible operating temperature: 85 °C								
Leakage class according to IEC 60534-4									
Valve plug	Standard	Metal seal	Standard: IV · High-performance metal seal: V ⁴⁾						
		Soft seal	VI						
	Balanced	Metal seal	Standard: IV · With PTFE or graphite pressure-balancing ring Special version: V · For high-performance (only with PTFE balancing ring) on request						

¹⁾ Special version: extended temperature range up to 450 °C when pressurized parts are made of cast steel 1.0619

²⁾ DN 200 and larger: down to -196 °C

³⁾ Long insulating section or bellows seal up to DN 150

⁴⁾ Leakage class V for temperatures <-50 °C on request

⁵⁾ Version for lower temperatures on request

Table 2: Materials

Standard version										
Valve body ¹⁾	Cast iron EN-GJL-250 (EN-JL1040)	Sph. graphite iron EN-GJS-400-18-LT (EN-JS1049)	Cast steel 1.0619	Cast stainless steel 1.4408	Cast steel 1.6220/1.1138	Cast stainless steel 1.4308	Forged steel 1.0460	Forged stainless steel 1.4404		
Valve bonnet	1.0460/EN-GJL-250	1.0460/1.0619		1.4408/1.4401-1.4404 ⁵⁾	1.0566/1.6220	1.4308/1.4301	1.0460	1.4401-1.4404 ⁵⁾		
Seat ²⁾	1.4006/1.4008			1.4404/1.4409	1.4006/1.4008	1.4301/1.4308	1.4006/1.4008	1.4404/1.4409		
Plug ²⁾	1.4006 (1.4404)/1.4008			1.4404/1.4409	1.4006 (1.4404)/1.4008	1.4301/1.4308	1.4006 (1.4404)/1.4008	1.4404/1.4409		
Plug seal	Seal ring for soft-seated plug: PTFE with glass fiber									
	Seal ring for balanced plug: PTFE with carbon or graphite ring							-		
Guide bushing	1.4104			1.4404	1.4404	1.4301	1.4104	1.4404		
Packing ³⁾	V-ring packing: PTFE with carbon · Spring: 1.4310									
Body gasket	Graphite on metal core									
Insulating section	1.0460			1.4401-1.4404 ⁵⁾		1.0566	1.4301	1.0460	1.4401-1.4404 ⁵⁾	
Bellows seal	Intermediate piece	1.0460			1.4401-1.4404 ⁵⁾		1.0566	1.4301	1.0460	1.4401-1.4404 ⁵⁾
	Bellows seal	1.4571 ⁴⁾				1.4541		1.4571 ⁴⁾		
Heating jacket	-			1.4404						

¹⁾ Special materials for applications with seawater: 1.4538, duplex 1.4470; nickel-based alloy: 9.4610; other special materials on request

²⁾ Seats and metal-seated plug also with Stellite® facing; for ≤DN 100 plug up to seat bore 38 made of solid Stellite® available.

³⁾ Other packings on request (see Information Sheet ► T 8000-1)

⁴⁾ Other materials on request

⁵⁾ Material double stamping

Table 3: K_{VS} coefficients

Terms for control valve sizing according to IEC 60534, Parts 2-1 and 2-2: $F_L = 0.95$, $X_T = 0.75$

Table 3.1: Overview with flow divider ST 1 (K_{VS-1}), ST 2 (K_{VS-2}) or ST 3 (K_{VS-3})

K_{VS}	0.1 0.16 0.25	0.4	0.63	1.0	1.6	2.5	4.0	6.3	10	16	25	40	60	80	63	100	160	200	260	250	360	630	1000 ¹⁾	1500 ¹⁾
K_{VS-1}	-			1.45	2.2	3.6	5.7	9	14.5	22	36	54	72	57	90	144	180	234	225	320	560	900 ¹⁾	1350 ¹⁾	
K_{VS-2}	-								8	13	20	32	48	63	50	80	125	160	210	200	290	500	800	1200
K_{VS-3}	-							7.5	12	20	30	-	-	47	75	120	-	-	190	270	480	750	-	
Seat Ø [mm]	3	6		12			24		31	38	48	63	80	63	80	100	110	130	125	150	200	250	300	
Travel in mm	15												30				60			120				

¹⁾ Not available with valve body made of cast iron (EN-GJL-250).

Table 3.2: Versions without flow divider · Areas highlighted in gray indicate versions also with pressure balancing

K_{VS}	0.1 0.16 0.25	0.4	0.63	1.0	1.6	2.5	4.0	6.3	10	16	25	40	60	80	63	100	160	200	260	250	360	630	1000	1500	
DN																									
15	•	•	•	•	•	•	•																		
20	•	•	•	•	•	•	•	•																	
25	•	•	•	•	•	•	•	•	•																
32		•	•	•	•	•	•	•	•	•															
40		•	•	•	•	•	•	•	•	•	•														
50		•	•	•	•	•	•	•	•	•	•	•													
65												•	•	•											
80												•	•	•	• ¹⁾										
100															•	•	•	•							
125															•	•	•	•	•						
150															•	•	•	•	•	•					
200																•	•			•	•	•			
250																•	•			•	•	•	•	• ²⁾	
300																	•			•	•	•	•	•	

¹⁾ With 19 mm overtravel (not with bellows seal)

²⁾ DN 250 with $K_{VS} = 1000$ not available with valve body made of cast iron (EN-GJL-250).

Table 3.3: Versions with flow divider ST 1 (K_{VS-1}) · Areas highlighted in gray indicate versions also with pressure balancing

K_{VS-1}	-	1.45	2.2	3.6	5.7	9	14.5	22	36	54	72	57	90	144	180	234	225	320	560	900	1350			
DN																								
15		•	•	•																				
20		•	•	•																				
25		•	•	•																				
32					•	•	•																	
40					•	•	•	•																
50					•	•	•	•	•															
65									•	•	•													
80									•	•	•	•												
100												•	•	•	•									
125												•	•	•	•	•								
150												•	•	•	•	•	•							
200													•	•			•	•	•					
250													•	•			•	•	•	•	• ¹⁾			
300														•			•	•	•	•	•	•		

¹⁾ DN 250 with $K_{VS-1} = 900$ not available with valve body made of cast iron (EN-GJL-250).

Table 3.1: Overview with flow divider ST 1 (K_{VS-1}), ST 2 (K_{VS-2}) or ST 3 (K_{VS-3})

K_{VS}	0.1 0.16 0.25	0.4	0.63	1.0	1.6	2.5	4.0	6.3	10	16	25	40	60	80	63	100	160	200	260	250	360	630	1000 ¹⁾	1500 ¹⁾
K_{VS-1}	-				1.45	2.2	3.6	5.7	9	14.5	22	36	54	72	57	90	144	180	234	225	320	560	900 ¹⁾	1350 ¹⁾
K_{VS-2}	-								8	13	20	32	48	63	50	80	125	160	210	200	290	500	800	1200
K_{VS-3}	-								7.5	12	20	30	-	-	47	75	120	-	-	190	270	480	750	-
Seat Ø [mm]	3	6		12			24		31	38	48	63	80	63	80	100	110	130	125	150	200	250	300	
Travel in mm	15												30						60			120		

¹⁾ Not available with valve body made of cast iron (EN-GJL-250).

Table 3.4: Versions with flow divider ST 2 (K_{VS-2}) · Areas highlighted in gray indicate versions also with pressure balancing

K_{VS-2}	-								8	13	20	32	48	-	50	80	125	160	210	200	290	500	800	1200
DN																								
15																								
20																								
25																								
32									•	•														
40								•	•	•														
50								•	•	•	•													
65										•	•	•												
80										•	•	•												
100														•	•	•								
125															•	•	•							
150														•	•	•		•						
200															•	•			•	•	•			
250															•	•			•	•	•			
300																•			•	•	•	•	•	•

Table 3.5: Versions with flow divider ST 3 (K_{VS-3}) · Areas highlighted in gray indicate versions also with pressure balancing

K_{VS-3}	-								7.5	12	20	30	-	-	47	75	120	-	-	190	270	480	750	-
DN																								
15																								
20																								
25																								
32																								
40																								
50									• ¹⁾															
65									•	•	•													
80									•	•	•													
100														•										
125															•	•	•							
150														•	•	•								
200															•	•			•	•	•			
250															•	•	•		•	•	•			
300																•			•	•	•	•	•	•

¹⁾ Not with bellows seal or insulating section

Differential pressures: Permissible differential pressures are listed in Information Sheet ► T 8000-4 .

Dimensions and weights

Table 4: Dimensions and weights for standard version of Type 3241-1 and Type 3241-7 Valves with flanges or welding ends

Table 4.1: Dimensions in mm for Type 3241 Valve up to DN 150 · Without actuator

Valve	DN	15	20	25	32	40	50	65	80	100	125	150	
Length L	mm	130	150	160	180	200	230	290	310	350	400	480	
H1 for actuator	≤750v2 cm ²	222			223			262		354	363	390	
	1000 cm ² 1400-60 cm ²	-									413	423	450
	1400-120 cm ² 2800 cm ²	-											
H2 ¹⁾ for	Cast steel	44 ²⁾			72	72 ²⁾		98	98 ²⁾	118	144	175	
	Forged steel	53	-	70	-	94	100	-	132	-			

¹⁾ The H2 dimension is the distance from the middle of the flow path to the bottom of the valve body.

²⁾ The H2 dimension in this valve is not the lowest point of the valve. This valve's lowest point is the bottom of the connecting flanges. The flange dimensions comply with the corresponding flange standard.

Table 4.2: Dimensions in mm for Type 3241 Valve in DN 200 and larger · Without actuator

Valve	DN	200 (cast iron body)	200	250 cast iron body up to SB 200 mm	250 up to 200 mm seat bore	250 seat bore 250 mm and larger	300
Length L	mm	600	600	730	730	730	850
H4	mm	390	390	390	451	451	652
H8 ¹⁾ for actuator	1000 cm ² 1400-60 cm ²	418	418	418	418	-	503
	1400-120 cm ² 2800 cm ²	503	503	503	503	650	650
H2	mm	260	230	260	295	295	355

¹⁾ H8 increases by 170 mm for valves with K_{Vs} 250, 360 or 630 and 60 mm rated travel operating with overtravel.

Table 4.3: Dimensions in mm for Types 3271 and 3277 Pneumatic Actuators

Actuator area	cm ²	120	175v2	240	350	355v2	700	750v2	1000	1400-60	1400-120	2800
Diaphragm ØD	mm	168	215	240	280	280	390	394	462	530	534	770
H ¹⁾	mm	69	78	62	82	121	199	236	403	337	598	713
H3 ²⁾	mm	110	110	110	110	110	190	190	610	610	650	650
H5	Type 3277 mm	88	101	101	101	101	101	101	-	-	-	-
Thread	Type 3271	M30x1.5						M60x1.5			M100x2	
	Type 3277	M30x1.5						-	-	-	-	
α	Type 3271	G ½ (½ NPT)	G ¼ (¼ NPT)	G ¼ (¼ NPT)	G ⅜ (⅜ NPT)	G ⅜ (⅜ NPT)	G ⅜ (⅜ NPT)	G ⅜ (⅜ NPT)	G ¾ (¾ NPT)	G ¾ (¾ NPT)	G 1 (1 NPT)	G 1 (1 NPT)
α2	Type 3277	-	G ⅜	G ⅜	G ⅜	G ⅜	G ⅜	G ⅜	-	-	-	-

¹⁾ Height including lifting eyelet or female thread and eyebolt according to DIN 580. Height of the swivel hoist may differ. Actuators up to 355v2 cm² without lifting eyelet or female thread

²⁾ Minimum clearance required to remove the actuator

Table 4.4: Weights ¹⁾ in kg for Types 3241-1 and 3241-7

Valve	DN	15	20	25	32	40	50	65	80	100	125	150	200	250 cast iron	250 -60/-120	300
Weight without actuator in kg		6	7.5	8	12	14	18	29	34	52	81	108	430	468	858	920

Actuator	cm ²	120	175v2	240	350	355v2	700	750v2	1000	1400-60	1400-120	2800
Type 3271	Without hand-wheel	2.5	6	5	8	15	22	36	80	70	175	450
	Handwheel ≤80 mm travel	4	10	9	13	20	27	41	180	175	300	575
	Handwheel ≤160 mm travel	-									425	700
Type 3277	Without hand-wheel	3.2	10	9	12	19	26	40	-			
	With handwheel	4.5	14	13	17	24	31	45	-			

¹⁾ The weights specified apply to a specific standard valve configuration. Weights of other valve configurations may differ depending on the version (material, trim or number of actuator springs etc.)

Table 5: Dimensions and weights ¹⁾ for Type 3241 Valve with insulating section or bellows seal**Table 5.1:** Dimensions in mm and weights in kg for Type 3241 Valve up to DN 150 · Without actuator

Valve size		15	20	25	32	40	50	65	80	100	125	150		
H4 for actuator	≤750v2 cm ²	Insulating section or bellows seal	409			410			451		636	645	672	
		Long	713			714			755		877	886	913	
	1000 cm ² / 1400-60 cm ²	Insulating section or bellows seal	-									695	705	732
		Long	-									936	946	973
	1400-120 cm ² / 2800 cm ²	Insulating section or bellows seal	-											
		Long	-											
Weight [kg]	With bellows seal	9	10.5	11	18	20	24	37	42	70	106	138		
	With long bellows seal	13	14.5	15	22	24	28	41	46	78	114	146		

Table 5.2: Dimensions in mm and weights in kg for Type 3241 Valve in DN 200 and larger · Without actuator

Version with		Insulating section					Bellows seal				
Valve DN (travel)	mm	200	250 (cast iron)	250 up to 200 mm seat bore	250 seat bore 250	300	200	250 (cast iron)	250 up to 200 mm seat bore	250 seat bore 250	300
Height H4	mm	830	830	1065	1065	1150	1036	1036	1492	1492	1520
H8 for actuator	1000 cm ² / 1400-60 cm ²	418	418	418	-	503	418	418	418	-	503
	1400-120 cm ² / 2800 cm ²	503	503	503	650	650	503	503	503	650	650
Weight (approx. kg)		478	928			963	520	975			1010

¹⁾ The weights specified apply to a specific standard valve configuration. Weights of other valve configurations may differ depending on the version (material, trim or etc.)

Table 6: Dimensions in mm for Type 3241 Valve with heating jacket · Not for valves with body materials EN-GJL-250 or EN-GJS-400-18-LT

Valve size	DN	25	32 to 50	65 to 80	100	150	200 to 300
a	mm	110	140	180	200	265	On request
b	mm	15	20	35	50	80	
c	mm	140	170	215	255	130	
d	mm	190	190	230	320	355	

Dimensional drawings

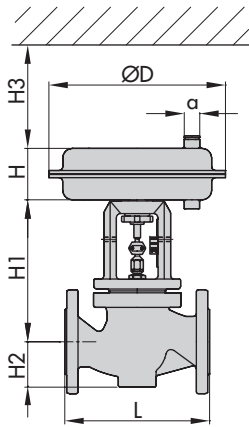

Type 3241-1 · DN 15 to 150

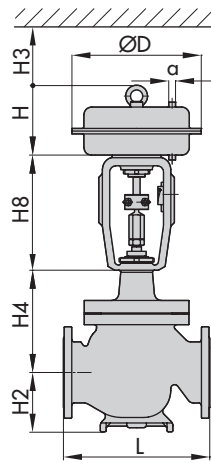

Type 3241-1 · DN 200 to 300

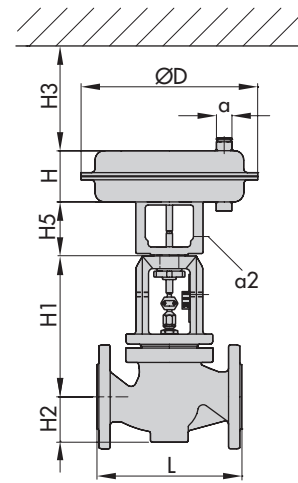

Type 3241-7 · DN 15 to 150

Type 3241 with insulating section or bellows seal

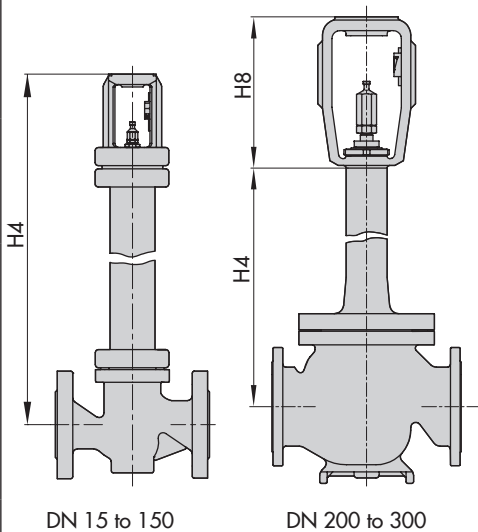

DN 15 to 150

DN 200 to 300

Type 3241 with heating jacket DN 25 to 100

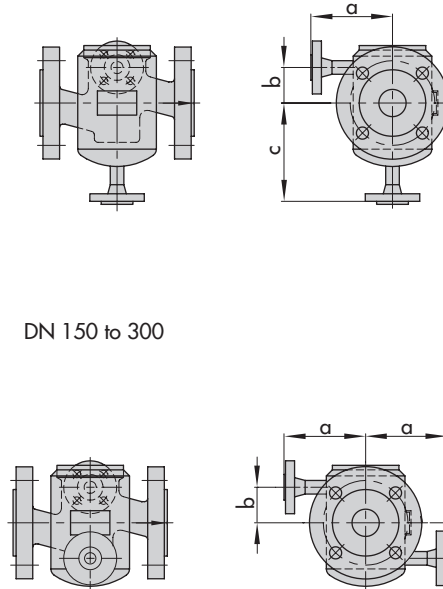

DN 150 to 300

Flanges, DIN 2635

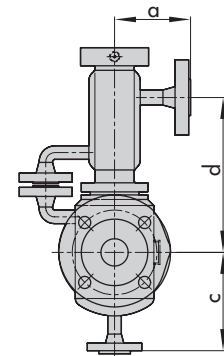

Bellows seal version with heating jacket

Ordering text

Globe valve	Type 3241
Valve size	DN ...
Pressure rating	PN ...
Body material	Refer to Table 2
Type of connection	Flanges or welding ends
Seat-plug seal	Soft seal, metal seal or high-performance metal seal
Characteristic	Equal percentage or linear
Pneumatic actuator	Type 3271 or Type 3277
Fail-safe position	Fail-close or fail-open
Process medium	Density and temperature

Max. flow rate	in kg/h or m ³ /h
Pressure	p ₁ and p ₂ in bar (absolute pressure)
RFID tag	Yes/No
Valve accessories	Positioner/limit switch

Associated Information Sheet ▶ T 8000-X
Associated Data Sheets for pneumatic actuators ▶ T 8310-1 to -3
Associated Mounting and Operating Instructions

Associated Safety Manual ▶ EB 8015
▶ SH 8015