

# MOUNTING AND OPERATING INSTRUCTIONS

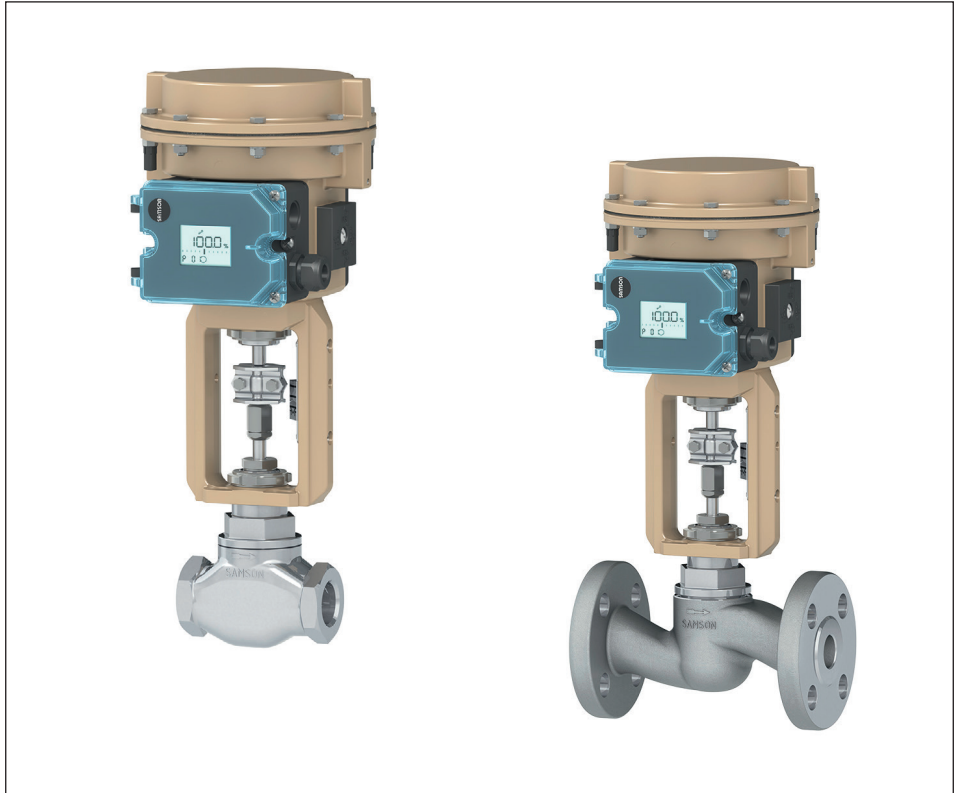

## EB 8822 EN

### Original instructions



### Type 3522 Globe Valve · ANSI version

In combination with an actuator,  
e.g. a SAMSON Type 3271 or Type 3277 Pneumatic Actuator

Edition February 2019

---

## Note on these mounting and operating instructions

These mounting and operating instructions assist you in mounting and operating the device safely. The instructions are binding for handling SAMSON devices.

- For the safe and proper use of these instructions, read them carefully and keep them for later reference.
- If you have any questions about these instructions, contact SAMSON's After-sales Service Department (samson@samsongroupna.com).

## Referenced documentation

The following documents apply in addition to these mounting and operating instructions:

- Mounting and operating instructions for mounted actuator, e.g. ► EB 8310-X for Type 3271 or Type 3277 Pneumatic Actuator
- Mounting and operating instructions for mounted valve accessories (e.g. solenoid valve)

The mounting and operating instructions for all supplied devices are included in the delivery. The latest versions of the documents are available on our website at

► [www.samsoncontrols.com](http://www.samsoncontrols.com).

## Definition of signal words

### DANGER

*Hazardous situations which, if not avoided, will result in death or serious injury*

### WARNING

*Hazardous situations which, if not avoided, could result in death or serious injury*

### NOTICE

*Property damage message or malfunction*

### Note

*Additional information*

### Tip

*Recommended action*

|          |  |           |
|----------|--|-----------|
| <b>1</b> | <b>Safety instructions and safety measures .....</b> | <b>5</b>  |
| 1.1      | Notes on possible severe personal injury .....       | 7         |
| 1.2      | Notes on possible personal injury .....              | 7         |
| 1.3      | Notes on possible property damage .....              | 8         |
| <b>2</b> | <b>Markings on the control valve .....</b>           | <b>10</b> |
| 2.1      | Valve nameplate .....                                | 10        |
| 2.2      | Actuator nameplate .....                             | 11        |
| 2.3      | Material number .....                                | 11        |
| <b>3</b> | <b>Design and principle of operation .....</b>       | <b>12</b> |
| 3.1      | Fail-safe positions .....                            | 12        |
| 3.2      | Technical data .....                                 | 14        |
| <b>4</b> | <b>Preparation .....</b>                             | <b>18</b> |
| 4.1      | Unpacking .....                                      | 18        |
| 4.2      | Transporting and lifting .....                       | 18        |
| 4.2.1    | Transporting .....                                   | 19        |
| 4.2.2    | Lifting .....  | 19        |
| 4.3      | Storage .....  | 20        |
| 4.4      | Preparation for installation .....                   | 21        |
| <b>5</b> | <b>Mounting and start-up .....</b>                   | <b>23</b> |
| 5.1      | Mounting the actuator onto the valve .....           | 23        |
| 5.1.1    | Versions with V-port plug .....                      | 23        |
| 5.1.2    | Mounting a Type 3271 or Type 3277 Actuator .....     | 24        |
| 5.2      | Installing the valve into the pipeline .....         | 24        |
| 5.2.1    | Checking the installation conditions .....           | 24        |
| 5.2.2    | Additional fittings .....                            | 26        |
| 5.2.3    | Installing the control valve .....                   | 26        |
| 5.3      | Quick check .....                                    | 26        |
| <b>6</b> | <b>Operation .....</b>                               | <b>28</b> |
| 6.1      | Reversing the flow direction .....                   | 28        |
| <b>7</b> | <b>Servicing .....</b>                               | <b>28</b> |
| 7.1      | Replacing the body gasket .....                      | 31        |
| 7.2      | Replacing the packing .....                          | 31        |

## Contents

|           |   |           |
|-----------|---|-----------|
| 7.3       | Replacing the seat and plug.....                  | 32        |
| 7.4       | Tools, tightening torques and lubricants.....     | 34        |
| 7.5       | Preparation for return shipment.....              | 36        |
| 7.6       | Ordering spare parts and operating supplies ..... | 36        |
| <b>8</b>  | <b>Malfunctions .....</b>                         | <b>38</b> |
| 8.1       | Troubleshooting .....                             | 38        |
| 8.2       | Emergency action .....                            | 39        |
| <b>9</b>  | <b>Decommissioning and disassembly .....</b>      | <b>40</b> |
| 9.1       | Decommissioning.....                              | 40        |
| 9.2       | Removing the valve from the pipeline.....         | 40        |
| 9.3       | Removing the actuator from the valve .....        | 40        |
| 9.4       | Disposal.....                                     | 40        |
| <b>10</b> | <b>Appendix.....</b>                              | <b>41</b> |
| 10.1      | Customer inquiries .....                          | 41        |
| 10.2      | Certificates .....                                | 41        |
| 10.3      | Spare parts .....                                 | 42        |

# 1 Safety instructions and safety measures

## Intended use

The SAMSON Type 3522 Globe Valve in combination with an actuator (e.g. Type 3271 or Type 3277 Pneumatic Actuator) is designed to regulate the flow rate, pressure or temperature of liquids, gases or vapors. The valve is designed for use in light industrial applications.

The valve with its actuator is designed to operate under exactly defined conditions (e.g. operating pressure, process medium, temperature). Therefore, operators must ensure that the control valve is only used in applications that meet the specifications used for sizing the valve at the ordering stage. In case operators intend to use the control valve in other applications or conditions than specified, SAMSON must be contacted.

SAMSON does not assume any liability for damage resulting from the failure to use the valve for its intended purpose or for damage caused by external forces or any other external factors.

→ Refer to the technical data and nameplate for limits and fields of application as well as possible uses.

## Reasonably foreseeable misuse

The control valve is not suitable for the following applications:

- Use outside the limits defined during sizing and in the technical data
- Use outside the limits defined by the valve accessories mounted on the control valve

Furthermore, the following activities do not comply with the intended use:

- Use of non-original spare parts
- Performing service and repair work not described in these instructions

## Qualifications of operating personnel

The control valve must be mounted, started up, serviced and repaired by fully trained and qualified personnel only; the accepted industry codes and practices are to be observed. According to these mounting and operating instructions, trained personnel refers to individuals who are able to judge the work they are assigned to and recognize possible hazards due to their specialized training, their knowledge and experience as well as their knowledge of the applicable standards.

## **Safety instructions and safety measures**

### **Personal protective equipment**

We recommend wearing the following protective equipment depending on the process medium:

- Protective clothing, gloves and eyewear in applications with hot, cold and/or corrosive media when working near or on the valve
  - Hearing protection when working near the valve
- ➔ Check with the plant operator for details on further protective equipment.

### **Revisions and other modifications**

Revisions, conversions or other modifications to the product are not authorized by SAMSON. They are performed at the user's own risk and may lead to safety hazards. Furthermore, the control valve may no longer meet the requirements for its intended use.

### **Safety devices**

Upon supply air or control signal failure, the valve moves to its fail-safe position (see section 3.1). The fail-safe action of the actuator is the same as its direction of action and is specified on the nameplate of SAMSON actuators (see actuator documentation).

### **Warning against residual hazards**

To avoid personal injury or property damage, plant operators and operating personnel must prevent hazards that could be caused in the control valve by the process medium, the operating pressure, the signal pressure or by moving parts by taking appropriate precautions. They must observe all hazard statements, warning and caution notes in these mounting and operating instructions, especially for installation, start-up and servicing.

### **Responsibilities of the operator**

The operator is responsible for proper operation and compliance with the safety regulations. Operators are obliged to provide these mounting and operating instructions to the operating personnel and to instruct them in proper operation. Furthermore, operators must ensure that operating personnel or third persons are not exposed to any danger.

### **Responsibilities of operating personnel**

Operating personnel must read and understand these mounting and operating instructions as well as the specified hazard statements, warning and caution notes. Furthermore, the operating personnel must be familiar with the applicable health, safety and accident prevention regulations and comply with them.

## Referenced standards and regulations

The SAMSON Type 3522 Globe Valve complies with the requirements of ASME B16.34, ASME B16.5 and ANSI/ISA 75.08.01-2002 (R2007).

## 1.1 Notes on possible severe personal injury

### DANGER

#### **Risk of bursting in pressure equipment.**

Control valves and pipelines are pressure equipment. Improper opening can lead to valve components bursting.

- Before starting any work on the control valve, depressurize all plant sections concerned and the valve.
- Drain the process medium from all the plant sections concerned as well as the valve.
- Wear personal protective equipment.

## 1.2 Notes on possible personal injury

### WARNING

#### **Crush hazard arising from moving parts.**

The control valve contains moving parts (actuator and plug stems), which can injure hands or fingers if inserted into the valve.

- Do not insert hands or fingers into the yoke while the valve is in operation.
- While working on the control valve, disconnect and lock the pneumatic air supply as well as the control signal.

#### **Risk of personal injury when actuator vents.**

While the valve is operating, the actuator may vent during closed-loop control or when the valve opens or closes.

- Install the control valve in such a way that the actuator does not vent at eye level.
- Use suitable silencers and vent plugs.
- Wear eye protection when working in close proximity to the control valve.

### WARNING

#### **Risk of personal injury due to residual process medium in the valve.**

While working on the valve, residual process medium can escape and, depending on its properties, may lead to personal injury, e.g. (chemical) burns.

- If possible, drain the process medium from all the plant sections concerned and the valve.
- Wear protective clothing, gloves and eyewear.

#### **Risk of burn injuries due to hot or cold components and pipelines.**

Depending on the process medium, valve components and pipelines may get very hot or cold and cause burn injuries.

- Allow components and pipelines to cool down or heat up.
- Wear protective clothing and gloves.

#### **Risk of personal injury due to preloaded springs.**

Valves in combination with pneumatic actuators with preloaded springs are under tension. These control valves with SAMSON pneumatic actuators can be identified by the long bolts protruding from the bottom of the actuator.

- Before starting any work on the actuator, relieve the compression from the preloaded springs (see associated actuator documentation).

## 1.3 Notes on possible property damage

### NOTICE

#### **Risk of valve damage due to contamination (e.g. solid particles) in the pipeline.**

The plant operator is responsible for cleaning the pipelines.

- Flush the pipelines before start-up.
- Observe the maximum permissible pressure for both the valve and plant.

#### **Risk of valve damage due to unsuitable medium properties.**

The valve is designed for a process medium with defined properties.

- Only use the process medium specified for sizing the valve.



**!** NOTICE

**Risk of leakage and valve damage due to excessively high or low tightening torques.**

Excessively tightened torques lead to parts wearing out quicker. Parts that are too loose may cause leakage.

→ Observe the specified tightening torques (see section 7.4).

**Risk of valve damage due to the use of unsuitable lubricants.**

The lubricants to be used depend on the valve material. Unsuitable lubricants may corrode and damage the valve surface.

→ Only use lubricants approved by SAMSON (see parts list and Table 9).

**Damage to health after contact with hazardous substances.**

Certain lubricants (e.g. 8150-4008) are classified as hazardous substances. These substances have a special label and a material safety data sheet (MSDS) issued by the manufacturer.

- Make sure that an MSDS is available for any hazardous substance used. If necessary, contact the manufacturer to obtain an MSDS.
- Inform operating personnel about the hazardous substances and their correct handling.

# 2 Markings on the control valve

## 2.1 Valve nameplate

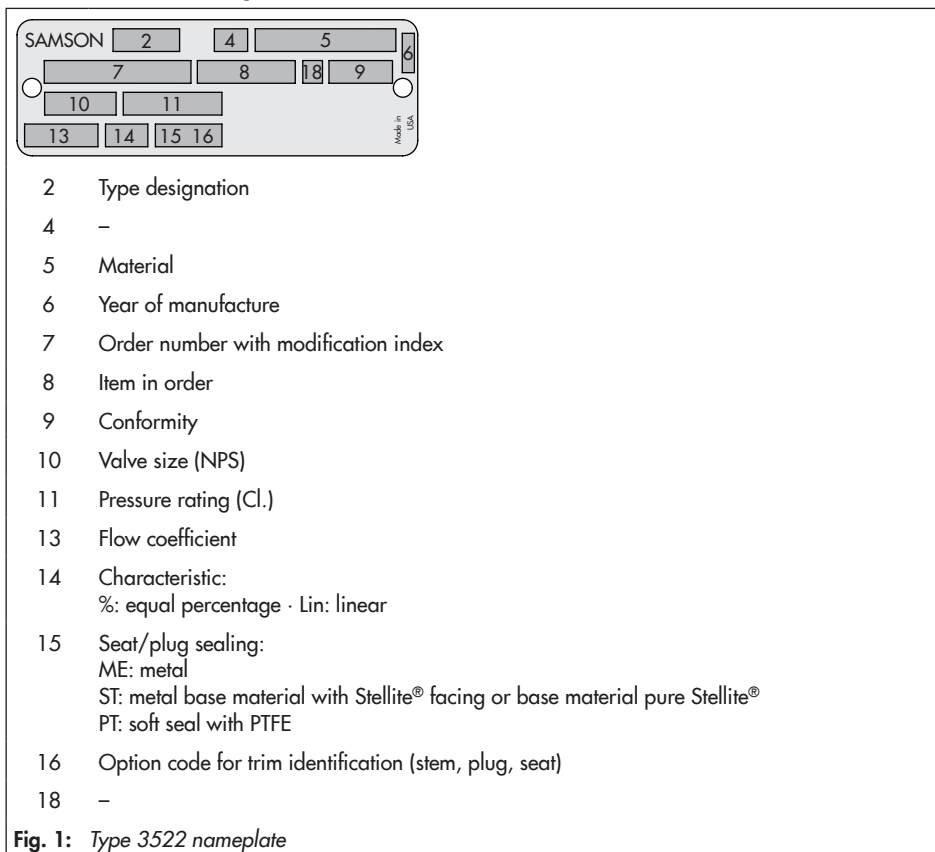

The valve nameplate is affixed to the rear of the body.

## 2.2 Actuator nameplate

See associated actuator documentation.

## 2.3 Material number

The seat and plug of the valves have an article number written on them. Specifying this article number, you can contact us to find out which material is used. Additionally, a seat code is used to identify the trim material (see Table 1). This seat code is specified on the nameplate (seat/plug seal, 15). For more details on the nameplate, see section 2.1.

**Table 1:** *Seat codes*

| Valve                    | Type 3522          |                          |                      |
|--------------------------|--------------------|--------------------------|----------------------|
| Stem material            | A479 316/A479 316L |                          |                      |
| Plug material            | A479 316/A479 316L | A182 F316/<br>A182 F316L | R30006 (Stellite® 6) |
| Seat material            | Seat code          |                          |                      |
| A479 316, A479 316L      | 04                 | 05                       | 06                   |
| A182 F316,<br>A182 F316L | 07                 | 08                       | 09                   |

### 3 Design and principle of operation

The single-seated Type 3522 Globe Valve is combined with a SAMSON Type 3271 or Type 3277 Pneumatic Actuator (see Fig. 2).

The seat (4) and plug with plug stem (5) are assembled in the body (1). The plug stem is connected to the actuator stem (A7) by the stem connector clamps (A26/27) and is sealed by a spring-loaded V-ring packing (15). The springs in the pneumatic actuator are located either above or below the diaphragm depending on the selected fail-safe action (see section 3.1). A change in the signal pressure acting on the diaphragm causes the plug to move. The actuator size is determined by the diaphragm area.

The medium flows through the valve in the direction indicated by the arrow. The valve normally operates in the flow-to-open direction (FTO). The medium flows across the plug from bottom to top.

A rise in signal pressure causes the force acting on the diaphragm in the actuator to increase. The springs are compressed. Depending on the selected direction of action, the actuator stem retracts or extends. As a result, the plug position in the seat changes and determines the flow rate through the valve.

#### Actuators

In these instructions, the combination with a Type 3271 or Type 3277 Pneumatic Actuator is described. The pneumatic actuator can be

replaced by another pneumatic actuator in a different size, but with the same travel.

→ Observe the maximum permissible actuator force.

---

#### **i** Note

*If the travel range of the actuator is larger than the travel range of the valve, the spring assembly in the actuator must be preloaded so that the travel ranges match. See associated actuator documentation.*

---

As an alternative, the control valve can be combined with a Type 3372 Electropneumatic Actuator (see ► T 8313).

### 3.1 Fail-safe positions

The fail-safe position depends on the actuator used. Depending on how the compression springs are arranged in the pneumatic actuator, the valve has two different fail-safe positions:

#### Actuator stem extends

When the signal pressure is reduced or the air supply fails, the springs move the actuator stem downward and close the valve. The valve opens when the signal pressure is increased enough to overcome the force exerted by the springs.

#### Actuator stem retracts

When the signal pressure is reduced or the air supply fails, the springs move the actuator stem upwards and open the valve. The valve closes when the signal pressure is in-

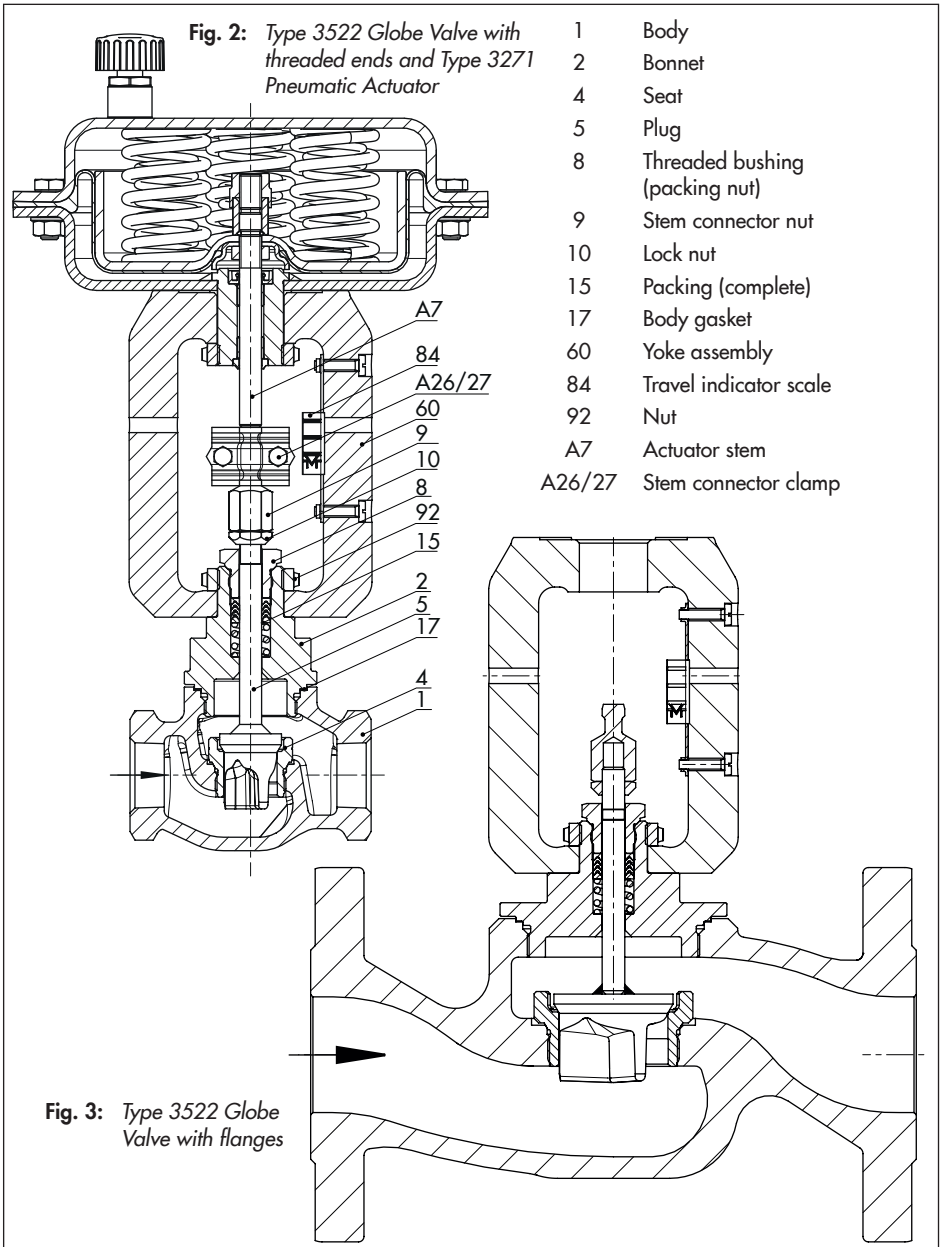

## Design and principle of operation

creased enough to overcome the force exerted by the springs.

### Tip

The actuator's direction of action can be reversed, if required. Refer to the mounting and operating instructions of the pneumatic actuator:

► EB 8310-X for Type 3271 and Type 3277

## 3.2 Technical data

The nameplates on the valve and actuator provide information on the control valve version. See section 2.1 and the actuator documentation.

### Note

More information is available in Data Sheet

► T 8822.

### Temperature range

The valve is designed for a temperature range from 14 to 430 °F (-10 to +220 °C).

### Leakage class

|  |         |    |
|--|---------|----|
| Seal (15 on nameplate)                   | ME, ST  | PT |
| Leakage class according to ANSI/FCI 70-2 | IV or V | VI |

### Noise emission

SAMSON is unable to make general statements about noise emission as it depends on the valve version, plant facilities, and process medium.

### WARNING

Risk of hearing loss or deafness due to loud noise.

Wear hearing protection when working near the valve.

### Dimensions and weights

Table 2 to Table 4 provide a summary of the dimensions and weights of the threaded and flanged version of Type 3522 Valve. The lengths and heights are shown in the dimensional drawings on p. 15 and p. 16.

**Table 2:** Dimensions of Type 3522 Valve - Version with threaded ends

| Globe valve      | Size  | NPS | ½    | ¾    | 1    | 1¼   | 1½   | 2    |
|------------------|---|-----|------|------|------|------|------|------|
| Length L         | Class 300                                       | in  | 3.5  | 3.5  | 4.31 | 4.63 | 5.31 | 6.66 |
|                  |   | mm  | 89   | 89   | 109  | 118  | 135  | 169  |
| H1 for actuators | Type 3271,<br>Type 3277<br>≤350 cm <sup>2</sup> | in  | 9.25 |      |      | 8.75 | 8.62 | 8.88 |
|                  |   | mm  | 235  |      |      | 222  | 219  | 225  |
|                  | Type 3372                                       | in  | 10.6 |      |      | -    |      |      |
|                  |   | mm  | 269  |      |      |      |      |      |
| H2               |   | in  | 1.13 | 1.13 | 1.38 | 1.50 | 1.68 | 1.75 |
|                  |   | mm  | 28.5 | 28.5 | 35   | 38   | 43   | 44.5 |

**Dimensional drawings**

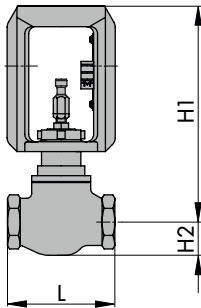

NPS ½ to 1, threaded ends

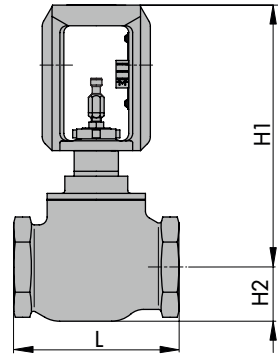

NPS 1¼ to 2, threaded ends

## Design and principle of operation

**Table 3:** Dimensions of Type 3522 Valve · Version with flanges

| Globe valve      | Size  | NPS | ½    | ¾   | 1   | 1¼ | 1½   | 2    |
|------------------|---|-----|------|-----|-----|----|------|------|
| Length L         | Class 150                                       | in  | 7.3  | 7.3 | 7.3 | -  | 8.7  | 10   |
|                  |   | mm  | 184  | 184 | 184 |    | 222  | 254  |
|                  | Class 300                                       | in  | 7.5  | 7.6 | 7.8 | -  | 9.3  | 10.5 |
|                  |   | mm  | 190  | 194 | 197 |    | 235  | 267  |
| H1 for actuators | Type 3271,<br>Type 3277<br>≤350 cm <sup>2</sup> | in  | 9.25 |     |     | -  | 8.62 | 8.88 |
|                  |   | mm  | 235  |     |     | -  | 219  | 225  |
|                  | Type 3372                                       | in  | 10.6 |     |     | -  |      |      |
|                  |   | mm  | 269  |     |     |    |      |      |
| H2               |   | in  | 1.3  | 1.2 | 1.4 | -  | 2.1  | 2.1  |
|                  |   | mm  | 33   | 31  | 36  | -  | 54.5 | 54.5 |

### Dimensional drawings

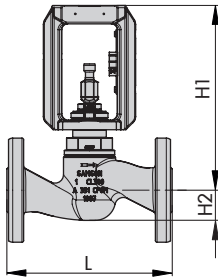

NPS ½ to 1, flanges

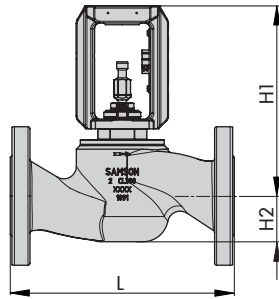

NPS 1½ to 2, flanges



**Table 4:** *Weights of Type 3522 Valve without actuator*

| Globe valve                | Size | NPS | ½    | ¾    | 1    | 1¼ | 1½   | 2    |
|----------------------------|------|-----|------|------|------|----|------|------|
| Version with threaded ends |      | lbs | 7    | 7.5  | 9    | 11 | 12   | 17   |
|                            |      | kg  | 3    | 3.4  | 4    | 5  | 5.4  | 7.7  |
| Version with flanges       |      | lbs | 11.5 | 14.8 | 16.8 | –  | 31.1 | 34.6 |
|                            |      | kg  | 5.2  | 6.7  | 7.6  | –  | 14.1 | 15.7 |

**i Note**

Refer to the following data sheets for more dimensions and weights:

- ▶ T 8310-1 for Type 3271 or Type 3277 Pneumatic Actuators up to 750 cm<sup>2</sup> actuator area
- ▶ T 8313 for Type 3372 Electropneumatic Actuator

### 4 Preparation

After receiving the shipment, proceed as follows:

1. Check the scope of delivery. Compare the shipment received against the delivery note.
2. Check the shipment for transportation damage. Report any damage to SAMSON and the forwarding agent (refer to delivery note).

#### 4.1 Unpacking

##### **i** Note

*Do not remove the packaging until immediately before installing the valve into the pipeline.*

Proceed as follows to lift and install the valve:

1. Remove the packaging from the valve.
2. Dispose of the packaging in accordance with the valid regulations.

##### **!** NOTICE

*Risk of valve damage due to foreign particles entering the valve.*

*The protective caps fitted on the valve's inlet and outlet prevent foreign particles from entering the valve and damaging it.*

*Do not remove the protective caps until immediately before installing the valve into the pipeline.*

#### 4.2 Transporting and lifting

##### **!** DANGER

*Hazard due to suspended loads falling.  
Stay clear of suspended or moving loads.*

##### **!** WARNING

*Risk of lifting equipment tipping and risk of damage to lifting accessories due to exceeding the rated lifting capacity.*

- Only use approved lifting equipment and accessories whose minimum lifting capacity is higher than the weight of the valve (including actuator, if applicable).
- Refer to section 3.2 for weights.

##### **!** WARNING

*Risk of personal injury due to control valve tipping.*

- Observe the valve's center of gravity.
- Secure the valve against tipping over or turning.

##### **!** NOTICE

*Risk of valve damage due to incorrectly attached slings.*

*The welded-on lifting eyelet on SAMSON actuators is only intended for mounting and removing the actuator as well as lifting the actuator without valve. Do not use this lifting eyelet to lift the entire control valve assembly.*

- When lifting the control valve, make sure that the slings attached to the valve body bear the entire load.

- Do not attach load-bearing slings to the actuator, handwheel or any other parts.
- Observe lifting instructions (see section 4.2.2).

**Tip**

SAMSON's After-sales Service department can provide more detailed transport and lifting instructions on request.

## 4.2.1 Transporting

The control valve can be transported using lifting equipment (e.g. crane or forklift).

- ➔ Leave the control valve in its transport container or on the pallet to transport it.
- ➔ Observe the transport instructions.

### Transport instructions

- Protect the control valve against external influences (e.g. impact).
- Do not damage the corrosion protection (paint, surface coatings). Remove any damage immediately.
- Protect the control valve against moisture and dirt.
- The permissible transportation temperature of standard control valves is  $-4$  to  $+149$  °F ( $-20$  to  $+65$  °C).

**Note**

Contact SAMSON's After-sales Service department for the transportation temperatures of other valve versions.

## 4.2.2 Lifting

To install a large valve into the pipeline, use lifting equipment (e.g. crane or forklift) to lift it.

### Lifting instructions

- Secure slings against slipping.
- Make sure the slings can be removed from the valve once it has been installed into the pipeline.
- Prevent the control valve from tilting or tipping.
- Do not leave loads suspended when interrupting work for longer periods of time.
- Make sure that the axis of the pipeline is always horizontal during lifting and the axis of the plug stem is always vertical.

### Version with threaded ends or flanges

1. Attach one sling to each threaded end or flange of the body and to the rigging equipment (e.g. hook) of the crane or forklift (see Fig. 4).
2. **Version with threaded ends:** Secure the slings attached to the body against slipping using a connector.
3. Carefully lift the control valve. Check whether the lifting equipment and accessories can bear the weight.
4. Move the control valve at an even pace to the site of installation.
5. Install the valve into the pipeline (see section 5.2).

## Preparation

6. Check whether the threaded connection is tight and the valve in the pipeline holds. Check whether an appropriate sealing is installed.
7. Remove slings and, if applicable, connector.

### Tip

We recommend using a hook with safety latch (see Fig. 4). The safety latch prevents

*the slings from slipping during lifting and transporting.*

## 4.3 Storage

### NOTICE

*Risk of valve damage due to improper storage.*

*– Observe storage instructions.*

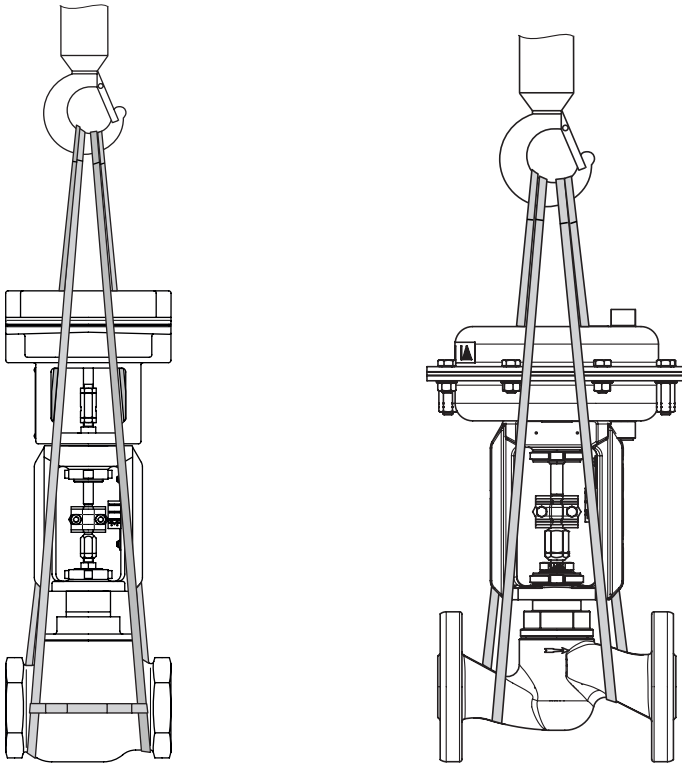

Fig. 4: Lifting points on the control valve

- Avoid long storage times.
- Contact SAMSON in case of different storage conditions or longer storage times.

---

**i Note**

We recommend regularly checking the control valve and the prevailing storage conditions during long storage times.

---

**Storage instructions**

- Protect the control valve against external influences (e.g. impact).
- Do not damage the corrosion protection (paint, surface coatings). Remove any damage immediately.
- Protect the control valve against moisture and dirt. Store it at a relative humidity of less than 75 %. In damp spaces, prevent condensation. If necessary, use a drying agent or heating.
- Make sure that the ambient air is free of acids or other corrosive media.
- The permissible storage temperature of standard control valves is  $-4$  to  $+149$  °F ( $-20$  to  $+65$  °C).

---

**i Note**

Contact SAMSON's After-sales Service department for the storage temperatures of other valve versions.

---

- Do not place any objects on the control valve.

**Special storage instructions for elastomers**

Elastomer, e.g. actuator diaphragm

- To keep elastomers in shape and to prevent cracking, do not bend them or hang them up.
- We recommend a storage temperature of  $59$  °F ( $15$  °C) for elastomers.
- Store elastomers away from lubricants, chemicals, solutions and fuels.

---

 **Tip**

SAMSON's After-sales Service department can provide more detailed storage instructions on request.

---

## 4.4 Preparation for installation

Proceed as follows:

- ➔ Flush the pipelines.

---

**i Note**

The plant operator is responsible for cleaning the pipelines. Observe the maximum permissible pressure for both the valve and plant.

---

- ➔ Check the valve to make sure it is clean.
- ➔ Check the valve for damage.
- ➔ Check to make sure that the type designation, valve size, material, pressure rating and temperature range of the valve match the plant conditions (size and pressure rating of the pipeline, medium temperature etc.).

## Preparation

- For steam applications, make sure that the pipelines are dry. Moisture will damage the inside of the valve.
- Check any mounted pressure gauges to make sure they function.
- When the valve and actuator are already assembled, check the tightening torques at the bonnet. Components may loosen during transport.

## 5 Mounting and start-up

SAMSON valves are delivered ready for use. In special cases, the valve and actuator are delivered separately and must be assembled on site. The procedure to mount and start up the valve are described in the following.

### NOTICE

*Risk of valve damage due to excessively high or low tightening torques.*

*Observe the specified torques on tightening control valve components. Excessively tightened torques lead to parts wearing out quicker. Parts that are too loose may cause leakage.*

*Observe the specified tightening torques (see section 7.4).*

### 5.1 Mounting the actuator onto the valve

#### Note

- Remove the mounted actuator before mounting the other actuator (see associated actuator documentation).
- Preloading the actuator springs increases the thrust of a pneumatic actuator and reduces the travel range of the actuator (see associated actuator documentation).

#### 5.1.1 Versions with V-port plug

Each V-port plug has three V-shaped ports. Depending on the valve size, the size of the symmetrically arranged V-shaped ports varies. The process medium in the valve flows through the V-shaped ports as soon as the plug is lifted out of the seat (i.e. the valve opens).

1. Before mounting the actuator, determine which V-shaped port is uncovered first when the plug is lifted out of the seat.

#### Tip

*Usually, this is the largest V-shaped port.*

2. On mounting the actuator, make sure that the V-shaped port uncovered first faces toward the valve outlet.

### NOTICE

*Medium flow obstructed due to incorrect installation of the V-port plug.*

*To achieve the best flow conditions inside the valve, the V-port plug must always be installed with the largest port facing toward the valve outlet.*

*Make sure the V-port plug is installed correctly.*

### 5.1.2 Mounting a Type 3271 or Type 3277 Actuator

Proceed as described in the actuator documentation if the valve and actuator have not been assembled by SAMSON.

## 5.2 Installing the valve into the pipeline

### 5.2.1 Checking the installation conditions

#### Pipeline routing

The inlet and outlet lengths vary depending on the process medium. To ensure the control valve functions properly, follow the installation instructions given below:

- Observe the inlet and outlet lengths (see Table 5). Contact SAMSON if the valve conditions or states of the medium process deviate.
- Install the valve free of stress and with the least amount of vibrations as possible. If necessary, attach supports to the valve.
- Install the valve allowing sufficient space to remove the actuator and valve or to perform service and repair work on them.

#### Mounting position

Generally, we recommend installing the valve with the actuator upright and on top of the valve.

- Contact SAMSON for alternative mounting positions.

#### Support or suspension

Depending on the valve version and mounting position, the control valve and pipeline must be supported or suspended. The plant engineering company is responsible in this case.

---

#### **!** NOTICE

*Premature wear and leakage due to insufficient support or suspension.*

*Attach a suitable support or suspension on the valve, if necessary.*

---

#### Vent plugs

Vent plugs are screwed into the exhaust air ports of pneumatic and electropneumatic devices. They ensure that any exhaust air that forms can be vented to the atmosphere (to avoid excess pressure in the device). Furthermore, the vent plugs allow air intake to prevent a vacuum from forming in the device.

- Locate the vent plug on the opposite side to the workplace of operating personnel.
- On mounting valve accessories, make sure that they can be operated from the workplace of the operating personnel.

---

#### **i** Note

*The workplace of operating personnel is the location from which the valve, actuator and any mounted valve accessories can be accessed to operate them.*

---

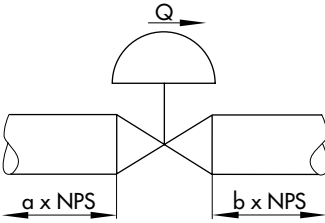

**Table 5: Inlet and outlet lengths**

| State of process medium   | Valve conditions   | Inlet length a | Outlet length b |
|---|--|----------------|-----------------|
|  |  |                |                 |
| <p>Q Flow rate<br/>a Inlet length<br/>b Outlet length</p>                         |  |                |                 |
| Gas   | $Ma \leq 0.3$  | 2              | 4               |
|   | $0.3 \leq Ma \leq 0.7$   | 2              | 10              |
| Vapor   | $Ma \leq 0.3$ <sup>1)</sup>  | 2              | 4               |
|   | $0.3 \leq Ma \leq 0.7$ <sup>1)</sup>                                 | 2              | 10              |
|   | Saturated steam (percentage of condensate > 5%)                      | 2              | 20              |
| Liquid  | Free of cavitation/ $w < 33$ ft/s<br>( $w < 10$ m/s)                 | 2              | 4               |
|   | Cavitation producing noise/ $w \leq 10$ ft/s ( $w \leq 3$ m/s)       | 2              | 4               |
|   | Cavitation producing noise/ $10 < w < 16$ ft/s<br>( $3 < w < 5$ m/s) | 2              | 10              |
|   | Critical cavitation/ $w \leq 10$ ft/s<br>( $w \leq 3$ m/s)           | 2              | 10              |
|   | Critical cavitation/ $10 < w < 16$ ft/s<br>( $3 < w < 5$ m/s)        | 2              | 20              |
| Flashing  | –  | 2              | 20              |
| Multi-phase   | –  | 10             | 20              |

<sup>1)</sup> No saturated steam

### 5.2.2 Additional fittings

#### Strainer

For certain applications an additional strainer can be installed to reduce excessive wear.

#### Bypass and shut-off valves

We recommend installing a shut-off valve both upstream of the strainer and downstream of the valve and setting up a bypass line. The bypass line ensures that the plant does not need to be shut down for service and repair work on the valve.

#### Insulation

Do not insulate valves mounted to comply with NACE MR 0175 requirements.

---

#### **i** Note

Contact SAMSON's After-sales Service department in case that an insulation is required.

---

### 5.2.3 Installing the control valve

1. Depressurize the plant and interrupt the medium flow while the valve is being installed.
2. Remove the protective caps from the valve ports before installing the valve.
3. Lift the valve using suitable lifting equipment to the site of installation (see section 4.2.2). Observe the flow direction through the valve. The arrow on the valve indicates the direction of flow.

4. Screw the valve onto the pipeline. Install an appropriate sealing. Make sure that the valve is free of stress.
5. Depending on the field of application, allow the valve to cool down or heat up to reach ambient temperature before start up.
6. Slowly resume medium flow in the pipeline after the valve has been installed.

---

#### **i** NOTICE

*Risk of valve damage due to a sudden pressure increase and resulting high flow velocities.*

*Slowly resume medium flow during start-up.*

---

7. Check the valve to ensure it functions properly.

### 5.3 Quick check

SAMSON valves are delivered ready for use. To test the valve's ability to function, the following quick checks can be performed:

#### Tight shut-off

1. Close the valve.
2. Slowly resume medium flow in the pipeline.

---

#### **i** NOTICE

*Risk of valve damage due to a sudden pressure increase and resulting high flow velocities.*

*Slowly resume medium flow during start-up.*

---

3. Check the valve for leakage to the atmosphere (visual inspection).

### Travel motion

The movement of the actuator stem must be linear and smooth.

- Open and close the valve, observing the movement of the actuator stem.
- Apply the maximum and minimum control signals to check the end positions of the valve.
- Check the travel reading at the travel indicator scale.

### Fail-safe position

- Shut off the signal pressure line.
- Check whether the valve moves to the fail-safe position.

### Pressure testing

When pressure testing make sure that the following conditions are met:

- Retract the plug to open the valve.
- Observe the maximum permissible pressure for both the valve and plant.

---

#### **i** Note

*The plant operator is responsible for pressure testing. SAMSON's After-sales Service department can support you in planning and implementing the pressure test for your plant.*

---

## 6 Operation

Immediately after completing mounting and start-up (see section 5), the valve is ready for use.

### WARNING

*Crush hazard arising from moving parts (actuator and plug stem).*

*Do not insert hands or finger into the yoke while the valve is in operation.*

### WARNING

*Risk of personal injury when the actuator vents.*

*Wear eye protection when working in close proximity to the control valve.*

### WARNING

*Risk of burn injuries due to hot or cold components and pipeline.*

*Valve components and the pipeline may become very hot or cold. Risk of burn injuries. Wear protective clothing and gloves.*

### NOTICE

*Operating disturbed by a blocked actuator and plug stem.*

*Do not impede the movement of the actuator or plug stem by inserting objects into their path.*

## 6.1 Reversing the flow direction

The medium flows through the valve in the direction indicated by the arrow. The standard version normally operates in the flow-to-open direction (FTO). The medium flows across the plug from bottom to top.

The flow direction can be reversed from FTO to FTC and vice versa.

### NOTICE

*Risk of valve damage due to altered forces. When reversing the flow direction, altered forces occur which may damage the valve if incorrectly calculated.*

*To reverse the flow direction, contact SAMSON's After-sales Service department.*

## 7 Servicing

The control valve is subject to normal wear, especially at the seat, plug and packing. Depending on the operating conditions, check the valve at regular intervals to prevent possible failure before it can occur.

### Tip

*SAMSON's After-sales Service department can support you to draw up an inspection plan for your plant.*

We recommend removing the valve from the pipeline for service or repair work (see section 9.2).

**⚠ DANGER**

*Risk of bursting in pressure equipment. Control valves and pipelines are pressure equipment. Improper opening can lead to valve components bursting.*

- Before starting any work on the control valve, depressurize all plant sections concerned and the valve.*
- Drain the process medium from all the plant sections concerned as well as the valve.*
- Wear personal protective equipment.*

**⚠ WARNING**

*Risk of personal injury due to residual process medium in the valve.*

*While working on the valve, residual process medium can escape and, depending on its properties, may lead to personal injury, e.g. (chemical) burns.*

*Wear protective clothing, gloves and eye-wear.*

**⚠ WARNING**

*Risk of burn injuries due to hot or cold components and pipeline.*

*Valve components and the pipeline may become very hot or cold. Risk of burn injuries.*

- Allow components and pipelines to cool down or heat up.*
- Wear protective clothing and gloves.*

**ⓘ NOTICE**

*Risk of valve damage due to incorrect servicing or repair.*

*Service and repair work must only be performed by trained staff.*

**ⓘ NOTICE**

*Risk of valve damage due to abrasion.*

*The plug and seat facings are very sensitive. Before unscrewing the bonnet from the body, apply a signal pressure to the actuator to slightly lift the plug off the seat. This prevents the plug and seat from being damaged.*

**ⓘ NOTICE**

*Risk of valve damage due to excessively high or low tightening torques.*

*Observe the specified torques on tightening control valve components. Excessively tightened torques lead to parts wearing out quicker. Parts that are too loose may cause leakage.*

*Observe the specified tightening torques (see section 7.4).*

**ⓘ NOTICE**

*Risk of valve damage due to the use of unsuitable lubricants.*

*The lubricants to be used depend on the valve material. Unsuitable lubricants may corrode and damage the valve surface. Only use lubricants approved by SAMSON (see parts list and Table 9).*

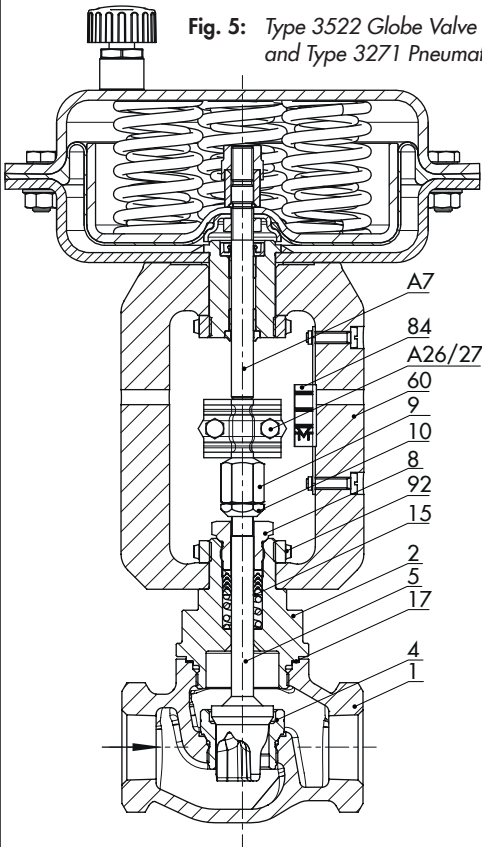

**Fig. 5:** Type 3522 Globe Valve with threaded ends and Type 3271 Pneumatic Actuator

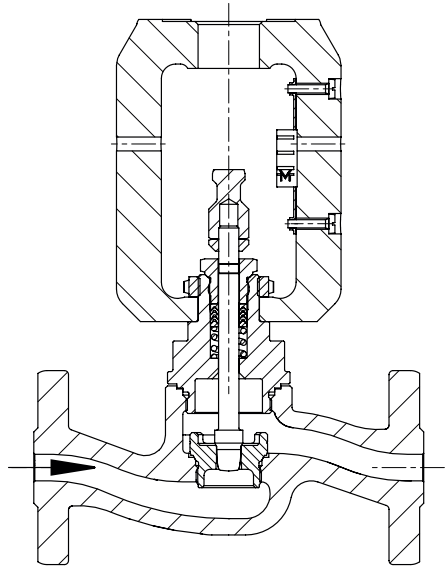

**Fig. 6:** Type 3522 Globe Valve with flanges

- |    |                                |        |                        |
|----|--------------------------------|--------|------------------------|
| 1  | Body                           | 15     | Packing (complete)     |
| 2  | Bonnet                         | 17     | Body gasket            |
| 4  | Seat                           | 60     | Yoke assembly          |
| 5  | Plug                           | 84     | Travel indicator scale |
| 8  | Threaded bushing (packing nut) | 92     | Nut                    |
| 9  | Stem connector nut             | A7     | Actuator stem          |
| 10 | Lock nut                       | A26/27 | Stem connector clamp   |

**i Note**

The control valve was checked by SAMSON before it left the factory.

- Certain test results (seat leakage and leak test) certified by SAMSON lose their validity when the valve body or actuator housing is opened.
- The product warranty becomes void if servicing or repair work not described in these instructions is performed without prior agreement by SAMSON's After-sales Service department.
- Only use original spare parts by SAMSON, which comply with the original specifications.

## 7.1 Replacing the body gasket

**i Note**

It is not necessary to remove the actuator from the valve to replace the body gasket.

1. Apply a signal pressure to the actuator to slightly lift the plug off the seat. Unscrew the bonnet (2).
2. Lift bonnet (2) and plug with plug stem (5) off the body (1).
3. Remove body gasket (17) from the bonnet (2) and carefully clean the grooves.
4. Insert new body gasket (17) into the bonnet (2). Make sure that the body gasket completely rests on the body's facing.
5. Apply a suitable lubricant to the bonnet (2).

6. Place bonnet (2) with plug and plug stem (5) onto the body (1).
7. Apply a signal pressure to the actuator to slightly lift the plug off the seat. Tighten the bonnet (2). Observe tightening torques.
8. Version with V-port plug: place the assembly onto the valve body, making sure that the largest V-shaped part of the V-port plug faces toward the valve outlet, see section 5.1.1.

## 7.2 Replacing the packing

1. Remove the actuator from the valve. See associated actuator documentation.
2. Unscrew nut (92) and lift the yoke (3) off the bonnet (2).
3. Unscrew the stem connector nut (9) and lock nut (10) from the plug stem (5).
4. Unscrew the threaded bushing (8).
5. Pull all the packing parts out of the packing chamber using a suitable tool.
6. Renew damaged parts. Clean the packing chamber thoroughly.
7. Apply a suitable lubricant to all the packing parts and to the plug stem (5).

**! NOTICE**

*Risk of damaging to the packing due to lubrication.*

*Do not lubricate graphite packings.*

8. Carefully slide the packing parts over the plug stem into the packing chamber us-

ing a suitable tool. Make sure to observe the proper order (see Fig. 7).

9. Versions with V-port plug: place the assembly onto the valve body, making sure that the largest V-shaped part of the V-port plug faces toward the valve outlet, see section 5.1.1.
10. Screw in the threaded bushing (8) and tighten it. Observe tightening torques.
11. Place yoke (3) on the bonnet (2) and fasten tight using the nut (92).
12. Loosely screw the lock nut (10) and stem connector nut (9) onto the plug stem (5).
13. Mount actuator and adjust travel. See associated actuator documentation.

## 7.3 Replacing the seat and plug

### NOTICE

*Risk of damage to the facing of the seat and plug due to incorrect service or repair. Always replace both the seat and plug.*

### Tip

*When replacing the seat and plug, we also recommend replacing the body gasket and the packing. See sections 7.1 and 7.2.*

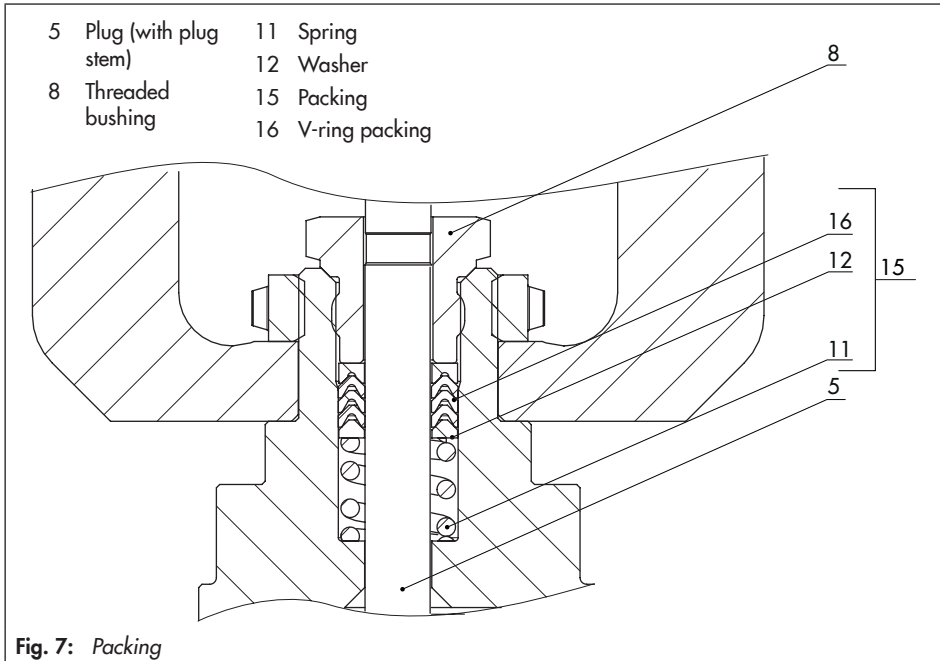



1. Remove the actuator from the valve. See associated actuator documentation.
2. Unscrew nut (92) and lift the yoke (3) off the bonnet (2).
3. Unscrew the bonnet (2) and lift the bonnet off the body (1).
4. Replace body gasket (17) as described in section 7.1.
5. Unscrew the stem connector nut (9) and lock nut (10) from the plug stem (5).
6. Unscrew the threaded bushing (8).
7. Pull the plug with the plug stem (5) out of the bonnet (2).
8. Replace packing (15) as described in section 7.2.
9. Unscrew the seat (4) using a suitable tool.
10. Apply a suitable lubricant to the thread and the sealing cone of the new seat.
11. Screw in the new seat (4) using a suitable tool. Observe tightening torques.
12. Apply a suitable lubricant to all the packing parts and to the new plug stem (5).
13. Slide the new plug with plug stem (5) into the bonnet (2).
14. Apply a suitable lubricant to the bonnet (2).
15. Screw bonnet (2) with plug and plug stem (5) into the body (1). Observe tightening torques.
16. Versions with V-port plug: place the assembly onto the valve body, making sure that the largest V-shaped part of the V-port plug faces toward the valve outlet, see section 5.1.1.
17. Screw in the threaded bushing (8) and tighten it. Observe tightening torques.
18. Place yoke (3) on the bonnet (2) and fasten tight using the nut (92).
19. Loosely screw the lock nut (10) and stem connector nut (9) onto the plug stem (5).
20. Mount actuator and adjust travel. See associated actuator documentation.

---

**NOTICE**

*Risk of damaging to the packing due to lubrication.*

*Do not lubricate graphite packings.*

---

13. Slide the new plug with plug stem (5) into the bonnet (2).
14. Apply a suitable lubricant to the bonnet (2).

## 7.4 Tools, tightening torques and lubricants

See Table 6, Table 7, Table 8, and Table 9.

### **⚠ WARNING**

*Damage to health after contact with hazardous substances.*

*Certain lubricants (e.g. 8150-4008) are classified as hazardous substances. These substances have a special label and a material safety data sheet (MSDS) issued by the manufacturer.*

- Make sure that an MSDS is available for any hazardous substance used. If necessary, contact the manufacturer to obtain an MSDS.*
- Inform operating personnel about the hazardous substances and their correct handling.*

**Table 6:** Tools and tightening torques for seat

| Version       | Nominal size NPS | Seat wrench order number | Tightening torques for seat |     |
|---------------|------------------|--------------------------|-----------------------------|-----|
|               |                  |                          | lb-ft                       | Nm  |
| Threaded ends | ½ to 1           | 9119-8002                | 125.4                       | 170 |
|               | 1¼ to 1½         | 9119-8005                | 221.3                       | 300 |
|               | 2                | 9110-2464                | 368.8                       | 500 |
| Flanges       | ½ to 1           | 9119-8002                | 125.4                       | 170 |
|               | 1½ to 2          | 9110-2464                | 368.8                       | 500 |

**Table 7:** Tools and tightening torques for bonnet

| Version       | Nominal size NPS | Bonnet tool order number | Tightening torques for bonnet made of |     |                 |     |       |     |
|---------------|------------------|--------------------------|---------------------------------------|-----|-----------------|-----|-------|-----|
|               |                  |                          | bronze                                |     | stainless steel |     | PTFE  |     |
|               |                  |                          | lb-ft                                 | Nm  | lb-ft           | Nm  | lb-ft | Nm  |
| Threaded ends | ½ to 1           | 9119-8006                | 148                                   | 200 | 185             | 250 | 192   | 260 |
|               | 1¼ to 1½         | 9119-8009                | 295                                   | 400 | 369             | 500 | 207   | 280 |
|               | 2                | 9119-8009                | 517                                   | 700 | 590             | 800 | 295   | 400 |
| Flanges       | ½ to 1           | 9119-8006                | –                                     | –   | 185             | 250 | 192   | 260 |
|               | 1½ to 2          | 9119-8009                | –                                     | –   | 590             | 800 | 295   | 400 |

**Table 8:** Other tightening torques

| Part             | Number within drawing | Tightening torque |    |
|------------------|-----------------------|-------------------|----|
|                  |                       | lb-ft             | Nm |
| Threaded bushing | 8                     | 37                | 50 |

**Table 9:** Lubricants sorted by parts

| Part            | Bonnet (female thread) | Seat      | Plug stem | Thread on plug stem (at the top) | Threaded bushing | Packing   |
|-----------------|------------------------|-----------|-----------|----------------------------------|------------------|-----------|
| Position number | 2                      | 4         | 5         | 5                                | 8                | 15        |
| Lubricant (113) | –                      | –         | 8150-0111 | –                                | –                | 8150-0111 |
| Lubricant (114) | 8150-4008              | 8150-4008 | –         | 8150-4008                        | 8150-4008        | –         |

**NOTICE**

*Risk of damaging to the packing due to lubrication.  
Do not lubricate graphite packings.*

### 7.5 Preparation for return shipment

Defective valves can be returned to SAMSON for repair.

Proceed as follows to return valves to SAMSON:

1. Put the control valve out of operation (see section 9).
2. Decontaminate the valve. Remove any residual process medium.
3. Fill in the Declaration on Contamination, which can be downloaded from the SAMSON AG website at  
▶ [www.samson.de](http://www.samson.de) > Services > Checklists for after-sales service > Declaration on Contamination.
4. Send the valve together with the filled-in form to your nearest SAMSON subsidiary. SAMSON subsidiaries are listed on our website at  
▶ [www.samsoncontrols.com](http://www.samsoncontrols.com) > Contact.

---

**i Note**

*For further information contact your nearest SAMSON subsidiary or the SAMSON After-sales Service department.*

---

### 7.6 Ordering spare parts and operating supplies

#### Spare Parts

See section 10.3 for details on spare parts.

#### Lubricants

Details on suitable lubricants can be found in the parts list and Table 9.



## 8 Malfunctions

Depending on the operating conditions, check the valve at certain intervals to prevent possible failure before it can occur. Operators are responsible for drawing up a test plan.



**Tip**

*SAMSON's After-sales Service department can support you to draw up an inspection plan for your plant.*

### 8.1 Troubleshooting

| Malfunction  | Possible reasons   | Recommended action  |
|--|--|---|
| Actuator or plug stem does not move on demand.               | Actuator is blocked.   | Check attachment.<br>Unblock the actuator.  |
|  | Signal pressure too low.   | Check the signal pressure.<br>Check the signal pressure line for leakage.   |
| Actuator or plug stem does not move through the whole range. | Signal pressure too low.   | Check the signal pressure.<br>Check the signal pressure line for leakage.   |
| The valve leaks to the atmosphere (fugitive emissions).      | The packing is defective.  | Replace packing (see section 7.2) or contact SAMSON's After-sales Service department.                                   |
|  | Thread joint loose or seal worn.                                     | Check the threaded joint.<br>Re-tighten, if necessary.<br>Check the seal at the threaded joint. Exchange, if necessary. |
|  | Body gasket worn out.  | Replace body gasket at the bonnet (see section 7.1) or contact SAMSON's After-sales Service department.                 |
| Increased flow through closed valve (seat leakage).          | Dirt or other foreign particles deposited between the seat and plug. | Shut off the section of the pipeline and flush the valve.   |
|  | Valve trim is worn out.  | Replace seat and plug (see section 7.3) or contact SAMSON's After-sales Service department.                             |

---

**i Note**

Contact SAMSON's After-sales Service department for malfunctions not listed in the table.

---

## 8.2 Emergency action

Upon supply air or control signal failure, the valve moves to its fail-safe position (see section 3.1).

Operators are responsible for emergency action to be taken in the plant.

In the event of a valve malfunction:

1. Depressurize the plant and interrupt the medium flow.
2. Check the valve for damage. If necessary, contact SAMSON's After-sales Service department.

### **Putting the valve back into operation after a malfunction**

- Slowly resume medium flow in the pipeline.

### 9 Decommissioning and disassembly

---

#### DANGER

*Risk of bursting in pressure equipment. Control valves and pipelines are pressure equipment. Improper opening can lead to valve components bursting.*

- *Before starting any work on the control valve, depressurize all plant sections concerned and the valve.*
  - *Drain the process medium from all the plant sections concerned as well as the valve.*
  - *Wear personal protective equipment.*
- 

#### WARNING

*Risk of personal injury due to residual process medium in the valve.*

*While working on the valve, residual process medium can escape and, depending on its properties, may lead to personal injury, e.g. (chemical) burns.*

*Wear protective clothing, gloves and eye-wear.*

---

#### WARNING

*Risk of burn injuries due to hot or cold components and pipeline.*

*Valve components and the pipeline may become very hot or cold. Risk of burn injuries.*

- *Allow components and pipelines to cool down or heat up.*
  - *Wear protective clothing and gloves.*
- 

### 9.1 Decommissioning

To decommission the control valve for service and repair work or disassembly, proceed as follows:

1. Interrupt the medium flow.
2. Completely drain the pipelines and valve.
3. Disconnect and lock the pneumatic air supply to depressurize the actuator.
4. If necessary, allow the pipeline and valve components to cool down or heat up.

### 9.2 Removing the valve from the pipeline

1. Put the control valve out of operation (see section 9.1).
2. **Version with threaded ends:** Unscrew the valve from the pipeline.  
**Version with flanges:** Unbolt the flange joint.
3. Remove the valve from the pipeline (see section 4.2).

### 9.3 Removing the actuator from the valve

See associated actuator documentation.

### 9.4 Disposal

- Observe local, national and international refuse regulations.
- Do not dispose of components, lubricants and hazard substances together with your other household waste.



## 10 Appendix

### 10.1 Customer inquiries

Contact SAMSON's After-sales Service department for support concerning servicing or repair work or when malfunctions or defects arise.

#### E-mail

You can reach the After-sales Service department at [samson@samsongroupna.com](mailto:samson@samsongroupna.com).

#### Addresses of SAMSON AG and its subsidiaries

The addresses of SAMSON AG, its subsidiaries, representatives and service facilities worldwide can be found on the SAMSON website, in all SAMSON product catalogs or on the back of these Mounting and Operating Instructions.

#### Required specifications

Please submit the following details:

- Order number and position number in the order
- Type, model number, nominal size and valve version
- Pressure and temperature of the process medium
- Flow rate
- Bench range of the actuator (e.g. 2.9 to 14.5 psi)
- Is a strainer installed?
- Installation drawing

### 10.2 Certificates

Certificates are available on request. Please contact After-sales Service department at [samson@samsongroupna.com](mailto:samson@samsongroupna.com).

### 10.3 Spare parts

- 1 Body
- 2 Bonnet
- 3 Yoke
- 4 Seat
- 5 Plug
- 8 Threaded bushing (packing nut)
- 9 Stem connector nut
- 10 Lock nut
- 11 Spring
- 12 Washer
- 15 Packing (complete)
- 16 V-ring packing
- 17 Body gasket
- 60 Yoke assembly with travel indicator scale  
(82, 83, 84)
- 80 Nameplate
- 81 Grooved pin
- 82 Screw
- 83 Hanger
- 84 Travel indicator scale
- 92 Nut

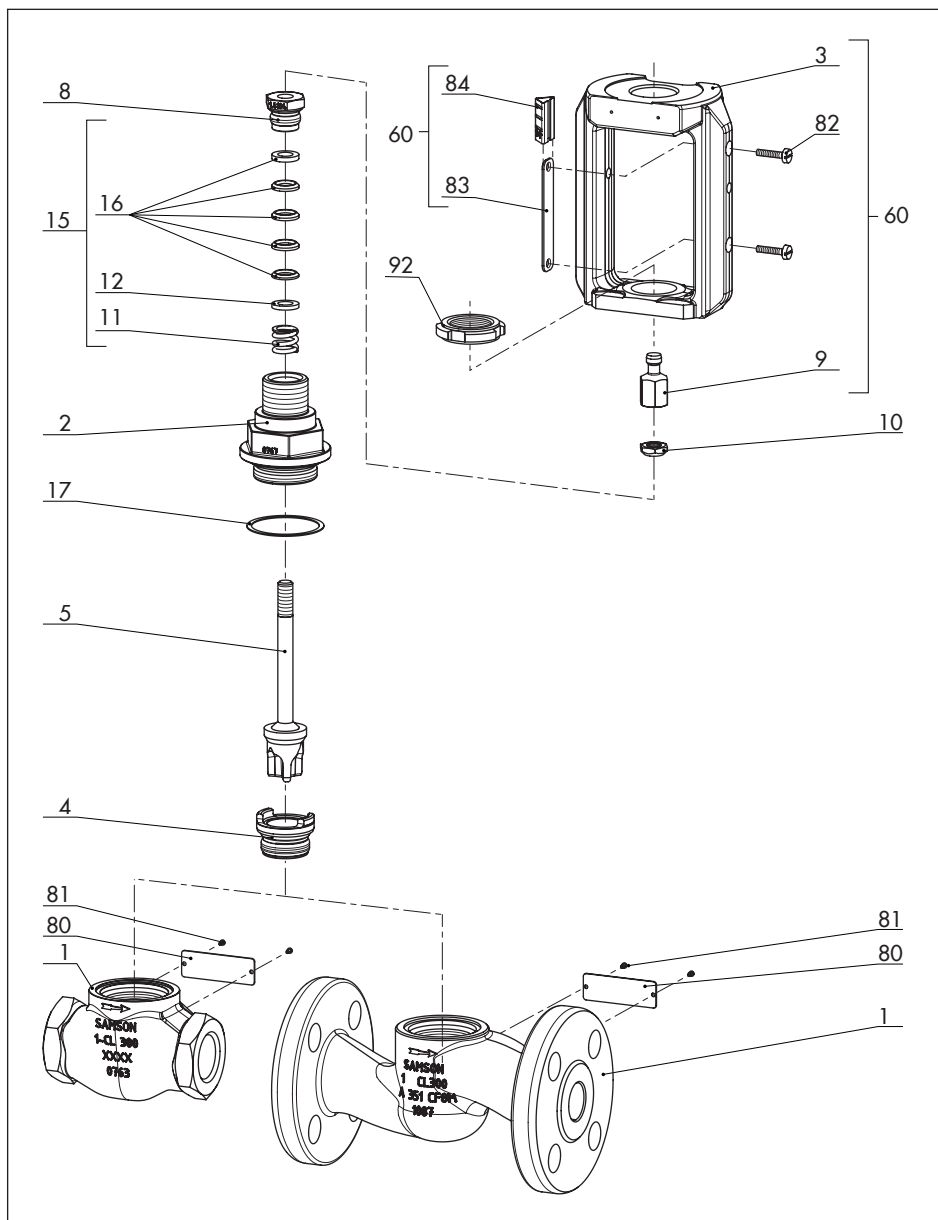



**SAMSON CONTROLS INC.**

4111 Cedar Boulevard · Baytown, Texas 77523-8588

Phone: +1 281 383-3677 · Fax: +1 281 383-3690

samson@samsongroupna.com · [www.samsoncontrols.com](http://www.samsoncontrols.com)